



- 4-DIGIT PROGRAMMABLE PROJECTION
- MULTIFUNCTION INPUT (DC, PM, RTD, T/C, DU)
- 4 I/O OUTPUTS
- RTC DATA RECORDING FACILITY
- DIGITAL FILTERS, TARE, LINEARIZATION
- SIZE OF DIN 96 X 48 MM
- POWER SUPPLY 80...250 V AC/DC
- Option
 - Data output • Analog output
 - Power supply 10...30 V AC/DC

OM 402PID



OM 402PID is a 4-digit versatile panel mount PID regulator designed for maximum flexibility and user comfort while maintaining a low price.

Type OM 402PID is a multifunction instrument with the option of configuration for 8 various input options, easily configurable in the instrument menu. In its basic configuration the OM 402PID has two regulatory relays and two relay alarm outputs. Desired value can either be constant, or defined by one of 14 programmes.

The instrument is based on a 8-bit microcontroller and a multichannel 24-bit sigma-delta converter, which secures high accuracy, stability and easy operation of the instrument.

OM 402PID VERSATILE PID REGULATOR

OPERATION

The instrument is set and controlled by five control keys located on the front panel. All programmable settings of the instrument may be performed in three adjusting modes:

LIGHT MENU is protected by optional number code and contains solely items necessary for instrument setting

PROFI MENU is protected by optional number code and contains complete instrument setting

USER MENU may contain arbitrary items from the programming menu (LIGHT/PROFI), which determine the right (see, change). Access w/o password.

Standard equipment is the OM Link interface, which together with operation program enables modification and filing of all instrument settings as well as perform firmware updates (with OML cable). The program is also designed for visualization and filing of measured values from more instruments.

All settings are stored in the EEPROM memory (they hold even after the instrument is switched off).

OPTION

INPUT OF DESIRED VALUE enables the regulator to be used for follow-up control. Both current and voltage inputs can be used.

DATA OUTPUTS are for their rate and accuracy suitable for transmission of the measured data for further projection or directly into the control systems. We offer isolated RS232 and RS485 with the ASCII/MESSBUS/MODBUS/PROFIBUS protocol.

STANDARD FUNCTIONS

PROGRAMMABLE PROJECTION

Selection: of input type and measuring range

Setting (UNI): manual, in menu optional projection on the display may be set for both limit values of the input signal, e.g. input 0...39,99 V ⇒ 0...850,0

Projection: -999...9999

PID REGULATOR

Execution: paralel PID, PI or proporcional

Relay output: double, two-state, PWM

Analogue output: electrically isolated, modes: heatinf, cooling, both

Required value: set, from the analogue output, from program

Number of programs/steps: 14/64

Launching: time - one off/weekly, by external input, by buttons

RELAY OUTPUTS

Type: digital, settable in the menu

Outputs: relays L1, L2 are alarm outputs, relays L3, L4 are intended as regulatory but can be also used as alarms

ANALOG OUTPUT

Usage: where this type of signal is requested by action devices, or it can be used for processing of the measured value by external devices.

Type: electrically isolated, programmable with a 12 bit D/A convertor. Functions, type and range of the output are seelctable in the instrument's menu

COMPENSATION

of conduct (RTD, OHM): automatic (3- and 4-wire) or manual in menu (2-wire)

of conduct in probe (RTD): internal connection (conduct resistance in measuring head)

of CJC (T/C): manual or automatic, in menu it is possible to perform selection of the type of thermocouple and compensation of cold junctions, which is adjustable or automatic (temperature at the input brackets)

DIGITAL FILTERS

Floating/Exp./Arithmetic average: from 2...30/100/100 measurements

Rounding: setting the projection step for display

MATHEMATIC FUNCTIONS

Min/max. value: registration of min/max. value reached during measurement

Tare: designed to reset display upon non-zero input signal

Peak value: the display shows only max. or min. value

Mat. operations: polynom, odmocnina

Linearization: through linear interpolation in 50 points (solely via OM Link)

TECHNICAL DATA

PROJECTION

Display: -999...9999, red 14-segment LED, digit height 14 mm
Secondary display: 2x -999...9999, green 7seg. LED, 9 mm tall
 The upper display shows the number of the program/step, the lower display shows the desired value
Signaling LED: yellow (regulation) - „+“, „-“, „3“, „4“
 red (alarm) - „1“, „2“, „3“, „4“
 green (Tare) - „T“, „+“
Decimal point: setting - in menu
Brightness: setting - in menu

INSTRUMENT ACCURACY

TK: 50 ppm/°C
Accuracy: ±0,1% of range + 1 digit (for projection 9999 and 5 meas/s) ±0,15% of range + 1 digit **RTD, T/C**
Accuracy of cold junction measurement: ±1,5°C
Rate: 0,1...40 meas/s
Overload capacity: 2x; 10x (t < 30 ms)
Linearization: by linear interpolation in 50 points
Digital filters: Exp/Floating/Arithmetic average, Rounding
Functions: offset, Min/max value, Tare, Peak value, Mat. operations
Ext. control: HOLD, LOCK, Tare, Min/Max and Functions PID
Data record: measured data record into instrument memory
RTC: - 15 ppm/°C, time-date-display value, < 256k data
Watch-dog: reset after 0,4 s
OM Link: Company communication interface for operation, setting and update of instruments
Calibration: at 25°C and 40 % r.h.

COMPARATOR

Type: digital, setting in menu, contact switch < 30 ms
Mod: Hysteresis, necitlivost, PWM
Limits: -999...9999
Hysteresis: 0...9999
Delay: 0...99,9 s
Output: 2x relays Form A (250 VAC/30 VDC, 3 A) and 2x Form C relays (250 VAC/50 VDC, 3 A) or 2x SSR

DATA OUTPUT

Protocol: ASCII, MESSBUS, MODBUS - RTU, PROFIBUS
Data format: 8 bit + no parity + 1 stop bit (ASCII)
 7 bit + even parity + 1 stop bit (Messbus)
Rate: 600...230 400 Baud
 9 600 Baud...12 Mbaud (PROFIBUS)
RS 232: isolated
RS 485: isolated, addressing (max. 31 instruments)

ANALOG OUTPUT

Type: isolated, programmable with 16-bit D/A converter, type and range are selectable in programming mode
Non-linearity: 0,1% of range
TK: 15 ppm/°C
Rate: response to change of value < 1 ms
Ranges: 0...2/5/10 V, ±10 V, 0...5 mA, 0/4...20 mA (comp. < 500 Ω/12 V or 1 000 Ω/24 V)

EXCITATION

Adjustable: 5...24 VDC/max. 1,2 W

POWER SUPPLY

10...30 V AC/DC, ±10 %, max. 13,5 VA, PF ≥ 0,4, I_{STP} < 40 A/1 ms
 80...250 V AC/DC, ±10 %, max. 13,5 VA, PF ≥ 0,4, I_{STP} < 40 A/1 ms
Power supply is protected by a fuse inside the instrument

MECHANIC PROPERTIES

Material: Noryl GFN2 SE1, incombustible UL 94 V-1
Dimensions: 96 x 48 x 120 mm
Panel cutout: 90,5 x 45 mm

OPERATING CONDITIONS

Connection: connector terminal board, section < 1,5/2,5 mm²
Stabilization period: within 15 minutes after switch-on
Working temperature: -20°...60°C
Storage temperature: -20°...80°C
Cover: IP64 (front panel only)
El. safety: EN 61010-1, A2
Dielectric strength: 4 kVAC after 1 min between supply and input
 4 kVAC after 1 min between supply and data/analog output
 4 kVAC after 1 min between supply and relay output
 2,5 kVAC after 1 min between input and data/analog output
Insulation resistance: for pollution degree II, measuring cat. III.
 Power supply > 670 V [ZI], 300 V [DI]
 input, output, Exc. > 300 V [ZI], 150 V [DI]
EMC: EN 61326-1

PI - Primary insulation, DI - Double insulation

MEASURING RANGES

OM 402PID is a multifunction instrument available in following ranges

DC: ±60/±160/±300/±1 200 mV
PM: 0...5/20 mA/4...20 mA; ±2/±5/±10/±40 V
OHM: 0...100 Ω/0...1/10/100 kΩ/Auto
RTD: Pt 50/100/500/1 000
Cu: Cu 50/100
Ni: Ni 1 000/10 000
T/C: J/K/T/E/B/S/R/N/L
DU: Linear potentiometer (min. 500 Ω)

The second input for setpoint (Option A)

PM: 0...5/20 mA/4...20 mA; ±2/±5/±10/±40 V

CONNECTING INDIVIDUAL INPUTS

	INPUT „I“	INPUT „U“
DC		±60/±160/±300/±1200 mV
PM	0...5/0...20 mA/4...20 mA	±2/±5/±10/40 V

CONNECTION

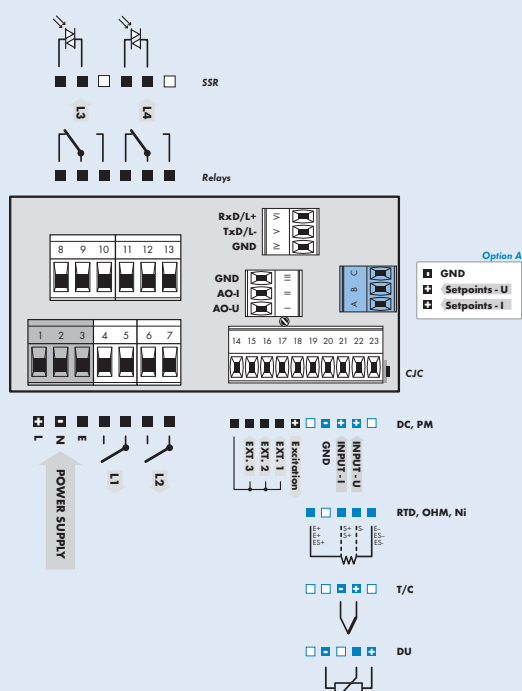

ORDER CODE

OM 402PID

		0	1	2	3	4	1
Power supply	10...30 V AC/DC	0					
	80...250 V AC/DC	1					
Input for setpoint	no		0				
	yes		A				
Regulatory outputs (output L3, L4)	relay		0				
	SSR		1				
Analog output	no			0			
	yes [Compensation < 500 Ω/12 V]			1			
	yes [Compensation < 1 000 Ω/24 V]			2			
Data output	none				0		
	RS 232				1		
	RS 485				2		
	MODBUS				3		
	PROFIBUS				4		
Excitation	yes						1
Other	customer version, do not fill in						00

Default execution is shown in bold

* Launch for sale has not been set