

UNIVERSAL PID REGULATOR

- 4-digit programmable projection
- Multifunction input (DC, PM, RTD, T/C, DU)
- 4 Outputs
- RTC with measured values record
- Digital filters, Tare, Linearization
- Size of DIN 96 x 48 mm
- Power supply 10...30 V AC/DC; 80...250 V AC/DC
- Option
Data output • Analog output

OM 402PID



OM 402PID is a 4-digit universal panel PID regulator designed for maximum flexibility and user comfort while maintaining its favourable price. It is a multifunction instrument with the option of configuration for 8 various input options, easily configurable in the instrument menu.

In its basic configuration the OM 402PID has two regulatory relays and two relay alarm outputs. Desired value can either be constant or defined by one of 14 programmes.

The instrument is based on a single-chip microcontroller and a multichannel 24-bit sigma-delta converter, which secures high accuracy, stability and easy operation of the instrument.

OM 402PID
UNIVERSAL PID REGULATOR

OPERATION

The instrument is set and controlled by five buttons located on the front panel. All programmable settings of the instrument may be performed in three adjusting modes:

LIGHT MENU is protected by optional number code and contains solely items necessary for instrument setting.

PROFI MENU is protected by optional number code and contains complete instrument setting.

USER MENU may contain arbitrary items from the programming menu (LIGHT/PROFI), which determine the right (see, change). Access w/o password.

Standard equipment is the OM Link interface, which together with operation program enables modification and filing of all instrument settings as well as performing firmware updates (with OML cable). The program is also designed for visualization and filing of measured values from more instruments.

All settings are stored in the EEPROM memory (settings hold even after the instrument is switched off).

OPTION

INPUT OF DESIRED VALUE enables the regulator to be used for follow-up control. Both current and voltage inputs can be used.

DATA OUTPUTS are for their rate and accuracy suitable for transmission of the measured data for further projection or directly into the control systems. We offer isolated RS232 and RS485 with the ASCII/PROFIBUS protocols.

STANDARD FUNCTIONS

PROGRAMMABLE PROJECTION

Selection: of input type and measuring range

Setting: manual, optional projection on the display may be set in menu for both limit values of the input signal, e.g. input 0...20 mA > 0...500.0

Projection: -999...9999

PID REGULATOR

Execution: parallel PID, PI or proportional

Relay output: double, two-state, PWM

Analog output: isolated, modes: heating, cooling, both

Required value: set, from analog output, from program

Number of programs/steps: 14/64

Launching: time - one-off/weekly, by external input, by buttons

RELAY OUTPUTS

Type: digital, adjustable in menu

Outputs: relays L1, L2 are alarm ones, relays L3, L4 are intended as regulatory but they can also be used as alarms

ANALOG OUTPUT

Usage: where this type of signal is requested by action devices, or it can be used for processing of the measured value by external devices

Type: isolated, programmable with a 12 bit D/A converter, functions, type and range of the output are selectable in the instrument's menu

COMPENSATION

Of conduct (RTD, OHM): automatic (3- or 4-wire) or manual in menu (2-wire)

Of conduct in probe (RTD): internal connection (conduct resistance in measuring head)

Of CJC (T/C): manual or automatic, in menu it is possible to perform selection of the type of thermocouple and compensation of cold junctions, which is adjustable or automatic (temperature of terminals)

DIGITAL FILTERS

Floating/Exp./Arithm. average: from 2...30/100/100 measurements

Rounding: setting the projection step for display

FUNCTIONS

Linearization: non-linear signals can be linearized by the means of a linearisat. table

Min./max. value: registration of min./max. value reached during measurement

Tare: designed to reset display upon non-zero input signal

Peak value: the display shows only max. or min. value

Mathemat. operations: polynom, root

TECHNICAL DATA

INPUT			
Number of inputs 1			
DC	Range	optional in configuration menu ±60 mV > 100 MΩ ±150 mV > 100 MΩ ±300 mV > 100 MΩ ±1 200 mV > 100 MΩ	Input U Input U Input U Input U
PM	Range	optional in configuration menu 0...20 mA < 400 mV 4...20 mA < 400 mV ±2 V 1 MΩ ±5 V 1 MΩ ±10 V 1 MΩ ±40 V 1 MΩ	Input I Input I Input U Input U Input U Input U
Required value optional extensions - by order range and setting is the same as option „PM“ connection to inputs - Required value U/I*			
OHM	Range	optional in configuration menu with autorange 0...100 Ω 0...1 kΩ 0...10 kΩ 0...100 kΩ	
Connection 2, 3 or 4 wire			
Pt	Type	optional in configuration menu EU > 100/500/1 000 Ω, 3 850 ppm/°C US > 100 Ω, 3 920 ppm/°C RU > 50 Ω, 3 910 ppm/°C RU > 100 Ω, 3 910 ppm/°C	-50°...450°C -50°...450°C -200°...1100°C -200°...450°C
Connection 2, 3 or 4 wire			
Ni	Type	optional in configuration menu Ni 1 000/10 000 with 5 000 ppm/°C Ni 1 000/10 000 with 6 180 ppm/°C	-50°...250°C -50°...250°C
Connection 2, 3 or 4 wire			
Cu	Type	optional in configuration menu Cu 50/100 with 4 260 ppm/°C Cu 50/100 with 4 280 ppm/°C	-50°...200°C -200°...200°C
Connection 2, 3 or 4 wire			
T/C	Type	optional in configuration menu J (Fe-CuNi) K (NiCr-Ni) T (Cu-CuNi) E (NiCr-CuNi) B (PtRh30-PtRh6) S (PtRh10-Pt) R (Pt13Rh-Pt) N (Omega alloy) L (Fe-CuNi)	-200°...900°C -200°...1 300°C -200°...400°C -200°...690°C 300°...1 820°C -50°...1 760°C -50°...1 740°C -200°...1 300°C -200°...900°C
DU	Pot. power supply	2 VDC/6 mA, Potentiometer resistance > 500 Ω	

Ext. inputs	3 inputs, on contact
The following functions can be assigned:	
OFF	input off
HOLD	display stop
LOCK	control keys blocking
PASS.	menu access blocking
TARE	tare activation
CL. TA.	tare resetting
CL. M.M.	resetting min/max value
SAVE	data recording start (FAST/RTC)
CL. ME.	data recording reset (FAST/RTC)
STOP R.	regulation stop
STAR. P.	running regulation to the spec. value
STAR. A	running regulation to „Required value“

PROJECTION
Display: -999...9999, single color 14-segment LED
Digit height: 14 mm
Display color: red or green
Auxiliary display: 2x -999...9999, green 7seg. LED, height 9 mm
The upper display shows the number of the program/step, the lower display shows the desired value
Signalling LED: yellow (regulation) - „.“, -“...„3“...„4“
 red (alarm) - „1“...„2“...„3“...„4“, green (tare) - „T“...„t“
Decimal point: adjustable - in menu
Brightness: adjustable - in menu

INSTRUMENT ACCURACY
TC: 50 ppm/°C
Accuracy: ±0.1% of range + 1 digit (for projection 9999 and 5 measur./s) ±0.15% of range + 1 digit **RTD, T/C**
Rate: 0.1...40 measurement/s
Overload capacity: 2x; 10x (t < 30 ms)
Resolution (RTD, T/C): 1/0.1°/0.01°C
Line compensation: max. 30 Ω (RTD)
Cold junction compens.: adjustable -20°...99°C or automatic
Linearization: linear interpolation in 50 points (only via OM Link)
Digital filters: Exp./Floating/Arithm. average, Rounding
Functions: Offset, Min/max value, Tare, Peak value, Mat. operations
Ext. operation: HOLD, LOCK, tare, Min/Max a functions PID
Data record: measured data record into instrument memory
 RTC - 15 ppm/°C, time-date-display value < 266k data
OM Link: company communication interface for operation, setting and update of instruments
Watch-dog: reset after 400 ms
Calibration: at 25°C and 40 % r.h.

COMPARATOR
Type: digital, menu adjustable, contact switch-on < 30 ms
Hysteresis mode: switching limit, hysteresis band (Lim and ±1/2 Hys.) and time (±99,9 s) determining the switching delay
Mode From-To: switching on and switching off interval
Mode double-state - L3 switches at negative deviation (INCREASE), L4 switches at positive deviation (DECREASE)
Mode PWM - L3 switches at negative deviation (INCREASE), L4 switches at positive deviation (DECREASE)

Mode Program - the relay is active after the program has ended, if the time „0“ is set - permanently, otherwise for a period of time „TIM. L2“

Mode Ready - the relay action occurs when the setpoint is reached for the first time, the relay turns off when the setpoint is changed; the relay is activated when the setpoint is reached; if the time „0“ is set - permanently, otherwise for the period of time „TIM. L1“

Output: 2x relays Form A (250 VAC/30 VDC, 3 A)
 2x relays FORM C (250 VAC/50 VDC, 3 A);
 4x open collector (250 VDC/100 mA) or 2x SSR (250 VAC/1 A)

DATA OUTPUTS

Protocol: ASCII, MESSBUS, MODBUS RTU, PROFIBUS DP
Data format: 8 bit + no parity + 1 stop bit (ASCII)
 7 bit + even parity + 1 stop bit (Messbus)
Rate: 600...230 400 Baud, 9 600 Baud...12 Mbaud (PROFIBUS)
RS 232: isolated
RS 485: isolated, addressing (max. 31 instruments)

ANALOGUE OUTPUT

Type: ei.isolated, programmable with a 16 bit D/A converter, functions, type and output range are selectable in the menu
Non-linearity: 0.1% of range
TC: 15 ppm/°C
Rate: response to change of value < 1 ms
Ranges: 0...2/5/10 V, ±10 V, 0...5 mA, 0/4...20 mA (comp. < 600 Ω/12 V or 1 000 Ω/24 V)

EXCITATION

Adjustable: 5...24 VDC/max. 1.2 W

POWER SUPPLY

Range: 10...30 V AC/DC, ±10 %, PF ≥ 0.4, I_{rip} < 40 A/1 ms, isolated
 80...250 V AC/DC, ±10 %, PF ≥ 0.4, I_{rip} < 40 A/1 ms, isolated
Consumption: < 9.4 W/9.2 VA
 Power supply is protected by a fuse inside the instrument.

MECHANICAL PROPERTIES

Material: Noryl GFN2 SE1, incombustible UL 94 V-1
Dimensions: 96 x 48 x 120 mm (w x h x d)
Panel cutout: 90.5 x 45 mm (w x h)

OPERATING CONDITIONS

Connection: connector terminal blocks, section < 1.5/2.5 mm²
Stabilization period: within 5 minutes after switch-on
Temperature working/storing: -20°...60°C/-20°...80°C
Protection: IP64 (front panel only)
EI. safety: EN 61010-1, A2
Dielectric strength: 4 kVAC per 1 min test between supply and input
 4 kVAC per 1 min test between supply and data/analog output
 4 kVAC per 1 min test between input and relay output
 2.5 kVAC per 1 min test between input and data/analog output
Insulation resistance: for pollution degree II, measuring cat. III power supply > 670 V (PI), 300 V (DI)
 input, output, PN > 300 V (PI), 150 V (DI)
EMC: EN 61326-1

PI - Primary insulation, DI - Double insulation

CONNECTION

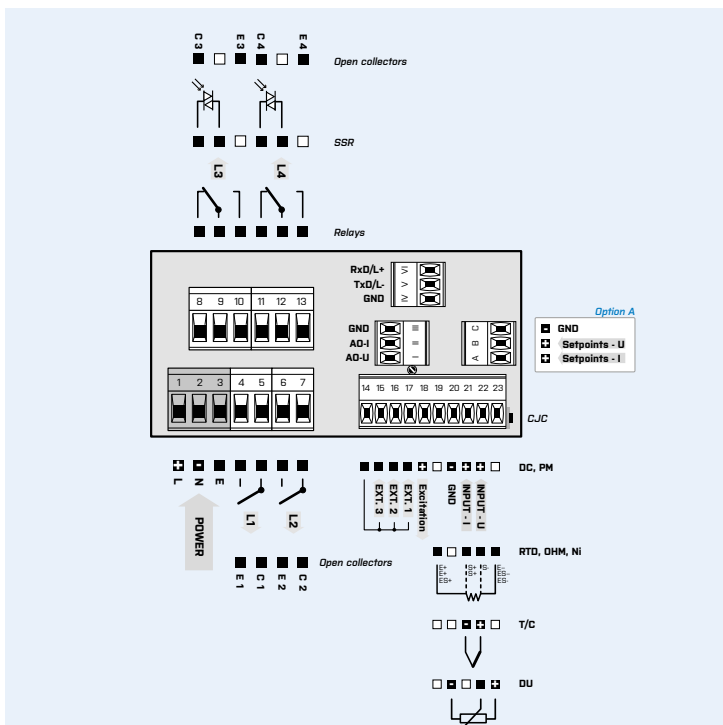

*For the „Requested value“ we recommend to connect terminals GND (main board/additional board) by external connection.

ORDER CODE

OM 402PID		-				1				-	
Power supply	10...30 V AC/DC	0									
	80...250 V AC/DC	1									
Input for the requested value	no		0								
	yes		A								
Alarm relays (outputs L3, L4)	relay			0							
	SSR			1							
Analog output	no				0						
	yes (compensation < 600 Ω/12 V)				1						
	yes (compensation < 1 000 Ω/24 V)				2						
Data output	none						0				
	RS 232						1				
	RS 485						2				
	MODBUS						3				
	PROFIBUS						4				
Excitation	yes								1		
Specification	customized version, do not fill in										00

Basic configuration of the instrument is indicated in bold.

* Launch for sale has not been set.