

OM 402



OM 402UNI DC VOLTMETER AND AMMETER
 PROCESS MONITOR
 OHMMETER
 THERMOMETER FOR Pt, Cu
 THERMOMETER FOR Ni
 THERMOMETER
 FOR THERMOCOUPLES
 DISPLAY UNIT FOR LINEAR
 POTENTIOMETERS

OM 402PWR AC NETWORK ANALYSER

Description

The OM 402 model series are 4 digit panel programmable instruments designed for maximum efficiency and user comfort while maintaining their favourable price. Two models are available: UNI and PWR.

Type OM 402UNI is a multifunction instrument with the option of configuration for 8 various input options, easily configurable in the instrument menu. By further options of input modules it is feasible to measure larger ranges of DC voltage and current or increase the number of inputs up to 4 (applies for PM). The instrument is based on an 8-bit microcontroller and multichannel 24-bit sigma-delta converter, which secures high accuracy, stability and easy operation of the instrument.

Operation

The instrument is set and controlled by five control keys located on the front panel. All programmable settings of the instrument may be performed in three adjusting modes:

Light menu is protected by optional number code and contains solely items necessary for instrument setting

Profi menu is protected by optional number code and contains complete instrument setting

User menu may contain arbitrary items from the programming menu (LIGHT/PROFI), which determine the right (see, change). Access w/o password.

Standard equipment is the OM Link interface, which together with operation program enables modification and filing of all instrument settings as well as perform firmware updates (with OML cable). The program is also designed for visualization and filing of measured values from more instruments.

All settings are stored in the EEPROM memory (they hold even after the instrument is switched off). The measured units may be projected on the display.

Options

Excitation is suitable for feeding of sensors and transmitters. It is isolated, with continuously adjustable value in the range of 5...24 VDC.

Comparators are assigned to monitor one, two, three or four limit values

- 4-digit programmable projection
- Multifunction device (DC, PM, RTD, T/C, DU)
- Digital filters, Tare, Linearization
- Size of DIN 96 x 48 mm
- Power supply 80...250 V AC/DC

OMLINK

Options

- Excitation • Comparators • Data output • Analog output • Data record
- Power supply: 10...30 V AC/DC • Three-color display - 20 mm

with relay output. The user may select limits regime: LIMIT/DOSING/FROM-TO. The limits have adjustable hysteresis within the full range of the display as well as selectable delay of the switch-on in the range of 0...99,9 s. Reaching the preset limits is signalled by LED and simultaneously by the switch-on of the relevant relay.

Data outputs are for their rate and accuracy suitable for transmission of the measured data for further projection or directly into the control systems. We offer an isolated RS232 and RS485 with the ASCII/MESSBUS/MODBUS/PROFIBUS protocol.

Analog outputs will find their place in applications where further evaluating or processing of measured data is required in external devices. We offer universal analog output with the option of selection of the type of output - voltage/current. The value of analog output corresponds with the displayed data and its type and range are selectable in menu.

Measured data record is an internal time control of data collection. It is suitable where it is necessary to register measured values. Two modes may be used. FAST is designed for fast storage (40 records/s) of all measured values up to 8 000 records. Second mode is RTC, where data record is governed by Real Time with data storage in a selected time segment and cycle. Up to 266 000 values may be stored in the instrument memory. Data transmission into PC via serial interface RS232/485 and OM Link.

Standard functions

PROGRAMMABLE PROJECTION

Selection: of input type and measuring range

Measuring range: adjustable as fixed or with automatic change

Measuring modes (PWR): voltage (V_{RMS}), current (A_{RMS}), real power (W), frequency (Hz) and with calculation of Q, S, $\cos \psi$

Setting: manual, in menu optional projection on the display may be set for both limit values of the input signal

Projection: -99999...999999

COMPENSATION

of conduct (RTD, OHM): automatic (3- and 4-wire) or manual in menu (2-wire)

of CJC (T/C): manual or automatic, in menu it is possible to perform selection of the type of thermocouple and compensation of cold junctions, which is adjustable or automatic (temperature at the input brackets)

LINEARIZATION

Linearization: by linear interpolation in 50 points (solely via OM Link)

DIGITAL FILTERS

Floating/Exp./Arithmetic average: from 2...30/100/100 measurements

Rounding: setting the projection step for display

MATHEMATIC FUNCTIONS

Min/max. value: registration of min/max. value reached during measurement

Tare: designed to reset display upon non-zero input signal

Peak value: the display shows only max. or min. value

Mat. operations: polynome, $1/x$, logarithm, exponential, power, root, $\sin x$

EXTERNAL CONTROL

Lock control keys blocking

Hold display/instrument blocking

Tare tare activation

Resetting MM resetting min/max value

Technical data

PROJECTION

Display: -99999...999999, red or green 14-segment LED, digit height 14 mm

-1999...9999, red/green/orange 7-segment LED, height 20 mm

Description: last two characters on the display may be used for description of measured quantities (adjustable in the menu)

Decimal point: setting - in menu

Brightness: setting - in menu

INSTRUMENT ACCURACY

TC: 50 ppm/°C

Accuracy: ±0,1% of range + 1 digit

±0,15% of range + 1 digit

RTD, T/C

±0,3% (0,6/0,9%) of range + 1 digit

PWR

The accur. applies for project. 9999 and rate 5 (2,5) meas./s (PWR)

Accuracy of cold junction measurement: ±1°C

Rate: 1,3...40 meas./s, 0,5...5 meas./s (PWR)

Overload capacity: 10x (t < 30 ms) - not for > 250 V, 5 A; 2x

Measuring modes (PWR): voltage (V_{BUS}), current (A_{BUS}), real power (W), frequency (Hz) and with calculation of Q, S, cos Ψ

Linearization: by linear interpolation in 50 points

Digital filters: Exp./Floating/Arithmetic average, Rounding

Functions: Offset, Min/max value, Tare, Peak value, Mat. operat.

Ext. control: HOLD, LOCK, Tare

Data record: measured data record into instrument memory

RTC - 15 ppm/°C, time-date-display value, < 266k data

FAST - display value, < 8k data

Resolution: 1°/0,1°/0,01°C

Watch-dog: reset after 0,4 s

OM Link: Company communication interface for operation, setting and update of instruments

Calibration: at 25°C and 40% r.h.

COMPARATOR

Type: digital, setting in prog. mode, contact switch < 30 ms

Limits: -99999...999999

Hysteresis: 0...999999

Delay: 0...99,9 s

Output: 2x relays Form A (250 VAC/30 VDC, 3 A)

and 2x Form C relays (250 VAC/50 VDC, 3 A), 2x/4x open collectors, 2x SSR, 2x bistable relays

DATA OUTPUT

Protocol: ASCII, MESSBUS, MODBUS - RTU, PROFIBUS

Data format: 8 bit + no parity + 1 stop bit

7 bit + even parity + 1 stop bit (Messbus)

Rate: 600...115 200 Baud, 9,6 kBaud...12 Mbaud (PROFIBUS)

RS 232: isolated

RS 485: isolated, addressing (max. 31 instruments)

Ethernet: 10/100BaseT, Security Protocols, POP3, FTP

ANALOG OUTPUT

Type: isolated, programmable with 12-bit D/A converter, type and range are selectable in programming mode

Non-linearity: 0,1% of range

TC: 15 ppm/°C

Rate: response to change of value < 1 ms

Ranges: 0...2/5/10 V, ±10 V, 0...5 mA, 0/4...20 mA

(comp. < 500 Ω/12 V or 1 000 Ω/24 V)

EXCITATION

Adjustable: 5...24 VDC/max. 1,2 W

POWER SUPPLY

10...30 V AC/DC, ±10%, max. 13,5 VA

80...250 V AC/DC, ±10%, max. 13,5 VA

Power supply is protected by a fuse inside the instrument

MECHANICAL PROPERTIES

Material: Noryl GFN2 SE1, incombustible UL 94 V-1

Dimensions: 96 x 48 x 120 mm

Panel cutout: 90,5 x 45 mm

OPERATING CONDITIONS

Connection: connector terminal board, section < 2,5 mm²

Stabilization period: within 15 minutes after switch-on

Working temperature: -20°...60°C, Storage: -20°...85°C

Cover: IP65 (front panel only), IP20

El. safety: EN 61010-1, A2

Dielectric strength: 4 kVAC after 1 min between supply and input

4 kVAC after 1 min between supply and data/analog output

4 kVAC after 1 min between supply and relay output

2,5 kVAC after 1 min between input and data/analog output

Insulation resistance: for pollution degree II, measuring cat. III.

power supply > 670 V (PI), 300 V (DI)

input, output, Exc. > 300 V (PI), 150 V (DI)

EMC: EN 61326-1

Seismic capacity: IEC 980: 1993, par. 6

SW validation: class B, C in compliance with IEC 62138, 61226

PI - Primary insulation, DI - Double insulation

Measuring ranges

OM 402 is a multifunction instrument available in following types and ranges

type UNI, standard (code „0“)

DC: ±60/±150/±300/±1 200 mV

PM: 0...5 mA/0...20 mA/4...20 mA/±2 V/±5 V/±10 V/±40 V

OHM: 0...100 Ω/0...1 kΩ/0...10 kΩ/0...100 kΩ/Auto

RTD: Pt 100/Pt 500/Pt 1 000

Cu: Cu 50/Cu 100

Ni: Ni 1 000/Ni 10 000

T/C: J/K/T/E/B/S/R/N/L

DU: Linear potentiometer (min. 500 Ω)

type UNI, option A

DC: ±0,1/±0,25/±0,5/±2/±5 A/±100 V/±25 V/±500 V

type UNI, option B (expansion about three inputs)

PM: 3x 0...5 mA/0...20 mA/4...20 mA/±2 V/±5 V/±10 V/±40 V

type LC

LC: 1...4/2...8/4...16 mV/V

type PWR

input U: 0...10 V/0...120 V/0...250 V/0...450 V

input I: 0...60 mV/0...150 mV/0...300 mV/0...1 A/0...2,5 A/0...5 A

Connecting individual inputs

	INPUT „I“	INPUT „U“
DC		±60/±150/±300/±1200 mV
PM	0...5/20 mA/4...20 mA	±2/±5/±10/40 V

Order code specification**

	UNI	LC	PWR	PWR
w/o	standard	1...4/2...8/4...16 mV/V		
A	±0,1/±0,25/±0,5/±2/±5 A ±100/±250/±500 V			
B	expansion about three inputs (PM)			
K				0...60/150/300 mV
P				0...1/2,5/5 A
S			0...10/120 V	
U			0...250/450 V	
Z	on request		on request	on request

Connection

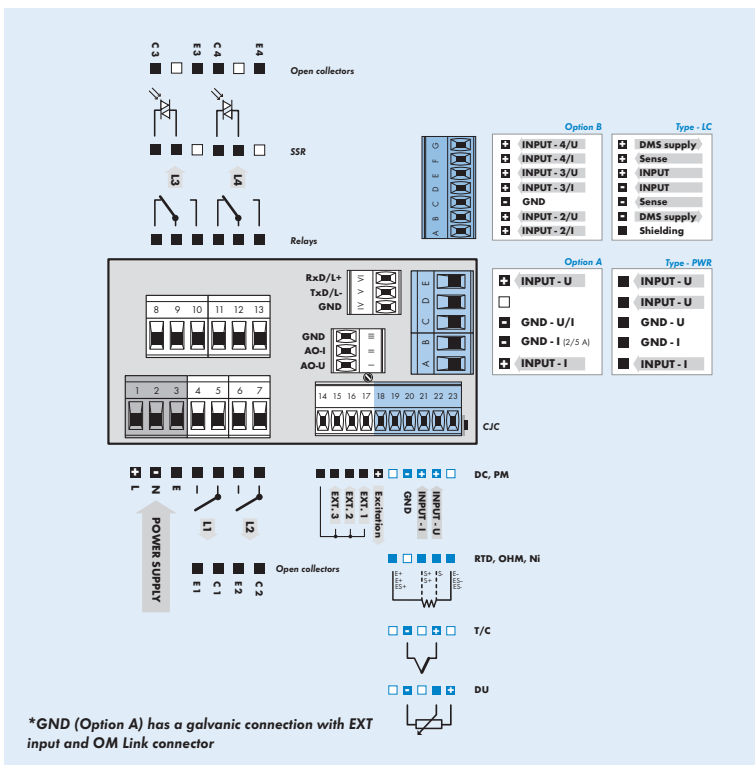

*GND (Option A) has a galvanic connection with EXT input and OM Link connector

Order code

OM 402	UNI	LC	PWR	PWR
Type	U N I	L C	P W R	P W R
Power supply	10...30 V AC/DC	0		
	80...250 V AC/DC	1		
Option, see table „Measuring ranges“		?		
Comparators	none		0	
	1x relay (Form A)		1	
	2x relays (Form A)		2	
	3x relays (2x Form A + 1x Form C)		3	
	4x relays (2x Form A + 2x Form C)		4	
	2x open collector		5	
	4x open collector		6	
	2x open collector + 2x relays (Form C)		7	
	2x relays (Form C)		8	
	2x SSR		9	
	2x bistable relays		A	
	1x relay (Form C)		B	
Analog output	no		0	
	yes (compensation < 500 Ω/12 V)		1	
	yes (compensation < 1 000 Ω/24 V)		2	
Data output	none		0	
	RS 232		1	
	RS 485		2	
	MODBUS		3	
	PROFIBUS		4	
	10/100BaseT Ethernet (not possible with analog output)*		7	
Excitation	no		0	
	yes		1	
Data record	no		0	
	RTC		1	
	FAST (only for UNI)		2	
Display color	red (14 mm)			1
	green (14 mm)			2
	red/green/orange (20 mm)			3
Other	customer version, do not fill in			00
	SW validation - IEC 62138, IEC 61226			VS