



## OM 502I

Type OM 502I is a precision 5-digit programmable panel integrator with projection of both integrated and instantaneous values.

The instrument is based on a single-chip microcontroller with a fast 24-bit sigma-delta converter, which secures high accuracy, stability and easy operation of the instrument..



### INTEGRATOR

- 5-digit programmable projection
- Range: 0...5 mA; 0...20 mA; 4...20 mA  
±2 V; ±5 V; ± 10V
- Mathematic functions, digital filters, Tare
- Accuracy: 0,02 %, Rate: 100 meas./s
- Size of DIN 96 x 48 mm
- Power supply 10...30 V AC/DC; 80...250 V AC/DC
- Option  
Comparators • Data output • Analog output • Data record

**OM 502I**  
INTEGRATOR

### OPERATION

The instrument is set and controlled by five buttons located on the front panel. All programmable settings of the instrument may be performed in three adjusting modes:

**LIGHT MENU** is protected by optional number code and contains solely items necessary for instrument setting.

**PROFI MENU** is protected by optional number code and contains complete instrument setting.

**USER MENU** may contain arbitrary items from the programming menu (LIGHT/PROFI), which determine the right (see, change). Access w/o password.

Standard equipment is the OM Link interface, which together with operation program enables modification and filing of all instrument settings as well as performing firmware updates (with OML cable). The program is also designed for visualization and filing of measured values from more instruments.

All settings are stored in the EEPROM memory (settings hold even after the instrument is switched off). The measured units may be projected on the display.

### OPTION

**COMPARATORS** are assigned to monitor one, two, three or four limit values with relay output. As a user you can select the mode limit: LIMIT/BATCH/FROM-TO. The limits have adjustable hysteresis within the full range of the display as well as selectable delay of the switch-on in the range of 0...99,9 s. Reaching the preset limits is signalled by LED and simultaneously by the switch-on of the relevant relay.

**DATA OUTPUTS** are for their rate and accuracy suitable for transmission of the measured data for further projection or directly into the control systems. We offer an isolated RS232 and RS485 with the ASCII/PROFIBUS protocols.

**ANALOG OUTPUTS** will find their place in applications where further evaluating or processing of measured data is required in external devices. We offer universal analog output with the option of selection of the type of output - voltage/current. The value of analog output corresponds with the displayed data. Its type and range are selectable in menu.

**MEASURED DATA RECORD** is an internal time control of data collection. It is suitable where it is necessary to register measured values. Two modes may be used. FAST is designed for fast storage (40 records/s) of all measured values up to 8 000 records. Second mode is RTC, where Data record is governed by Real Time with data storage in a selected time segment and cycle. Up to 266 000 values may be stored in the instrument memory. Data transmission into PC via serial interface RS232/485 and OM Link.

### STANDARD FUNCTIONS

#### PROGRAMMABLE PROJECTION

**Setting:** manual, in menu optional projection on the display can be set for both limit values of the input signal (e.g. input 4...20 mA > 0...500,0), dividing and multiplying constant, deadband or suppression of negative value

**Time base:** 1 s, projection of both integrated and instantaneous values  
Projection: -99999...99999

#### EXCITATION

**Range:** 5...24 VDC/1,2 W, for feeding sensors and transmitters

#### FUNCTIONS

**Linearization:** non-linear signals can be linearized by the means of a linearization table (up to 50 points)

**Min./max. value:** registration of min./max. value reached during measurement

**Tare:** designed to reset display upon non-zero input signal

**Peak value:** the display shows only max. or min. value

**Mathemat. operations:** polynom, 1/x, logarithm, exponential, power, root, sin x

#### DIGITAL FILTERS

**Floating average:** from 2...30 measurements

**Exponential average:** from 2...100 measurements

**Arithmetic average:** from 2...100 measurements

**Rounding:** setting the projection step for display

#### EXTERNAL CONTROL

**Lock:** control keys blocking

**Hold:** display/instrument blocking

**Tare:** tare activation

**Resetting MM:** resetting min./max. value

## TECHNICAL DATA

### INPUT

Number of inputs	1		
Range	optional in configuration menu		
	0...5 mA	< 300 mV	Input I
	0...20 mA	< 300 mV	Input I
	4...20 mA	< 300 mV	Input I
	±2 V	1,8 MΩ	Input U
	±5 V	1,8 MΩ	Input U
±10 V	1,8 MΩ	Input U	
Time base	1 s		
Multipl. constant	1...100 000		
Dividing constant	1/10/60/100/1 000/3 600		
Deadband	signal integration up from the set value 1...100 000		
Negative value	option allows to suppress negative signal value, the device integrates only in positive values (adds)		
Autom. resetting	setting of an automatic reset on display overflow		
Ext. inputs	3 inputs, on contact		
	The following functions can be assigned:		
	OFF	input off	
	HOLD	display stop	
	LOCK	control keys blocking	
	PASS.	menu access blocking	
	TARE	tare activation	
	CL. TA.	tare resetting	
	CL. M.M.	resetting min/max value	
	SAVE	data recording start (FAST/RTC)	
	CL. ME.	data recording reset (FAST/RTC)	
	CL. I.	integrated value reset	
	CL.SUM.	sum reset	
	CHAN. A.	value display „Channel A“	
	FIL. A.	value display „Channel A“ + filter	
	MAT. FN.	value display „Math. functions“	

### PROJECTION

Display: -99999...999999, single color 14-segment LED;  
 Digit height: 14 mm  
 Display color: red or green  
 Description: the last two characters on the display can be used to describe the measured quantities  
 Decimal point: adjustable - in menu  
 Brightness: adjustable - in menu

**INSTRUMENT ACCURACY**  
 TC: 50 ppm/°C  
 Accuracy: ±0,02% of range + 1 digit (for projection 99999 and 10 meas./s)  
 Rate: 1...100 measurement/s  
 Overload capacity: 2x; 10x (t < 30 ms)  
 Linearization: linear interpolation in 50 points (only via OM Link)  
 Digital filters: Exp/Floating/Arithm. average, Rounding  
 Functions: Offset, Min/max value, Tare, Peak value, Mat. operations  
 Data record: measured data record into instrument memory  
 RTC - 15 ppm/°C, time-date-display value < 266k data  
 FAST - display value < 8k data  
 Watch-dog: reset after 400 ms  
 OM Link: company communication interface for operation, setting and update of instruments  
 Calibration: at 25°C and 40 % r.h.

### COMPARATOR

Type: digital, menu adjustable, contact switch-on < 30 ms  
 Hysteresis mode: switching limit, hysteresis band (Lim and ±1/2 Hys.) and time (±99,9 s) determining the switching delay  
 Mode From-To: switching on and switching off interval  
 Mode Batch: period, its multiples and time (0...99,9 s), within which the output is active  
 Output: 1...2x relays Form A (250 VAC/30 VDC, 3 A)  
 and 1...2x relays Form C (250 VAC/50 VDC, 3 A);  
 2x/4x open collector (30 VDC/100 mA); 2x SSR (250 VAC/1 A);  
 2x bistable relays (250 VAC/250 VDC, 3 A/0,3 A)

### DATA OUTPUTS

Protocol: ASCII, MESSBUS, MODBUS RTU, PROFIBUS DP  
 Data format: 8 bit + no parity + 1 stop bit (ASCII)  
 7 bit + even parity + 1 stop bit (Messbus)  
 Rate: 600...230 400 Baud  
 9 600 Baud...12 Mbaud (PROFIBUS)  
 RS 232: isolated  
 RS 485: isolated, addressing (max. 31 instruments)

### ANALOG OUTPUTS

Type: isolated, programmable with a 16-bit D/A converter, output type and range are optional in the menu  
 Non-linearity: 0,1% of range  
 TC: 15 ppm/°C  
 Rate: response to change of value < 1 ms  
 Ranges: 0...2/5/10 V, ±10 V, 0...5 mA, 0/4...20 mA  
 (comp. < 600 Ω/12 V or 1 000 Ω/24 V)

### EXCITATION

Adjustable: 5...24 VDC/max. 1,2 W, separated

### POWER SUPPLY

Range: 10...30 V AC/DC, ±10 %, PF≥0,4, I<sub>ITP</sub> < 40 A/1 ms, isolated  
 80...250 V AC/DC, ±10 %, PF≥0,4, I<sub>ITP</sub> < 40 A/1 ms, isolated  
 Consumption: < 8,0 W/7,8 VA  
 Power supply is protected by a fuse inside the instrument.

### MECHANIC PROPERTIES

Material: Noryl GF20 SE1, incombustible UL 94 V-I  
 Dimensions: 96 x 48 x 120 mm (w x h x d)  
 Panel cutout: 90,5 x 45 mm (w x h)

### OPERATING CONDITIONS

Connection: connector terminal blocks, section < 1,5/2,5 mm<sup>2</sup>  
 Stabilization period: within 5 minutes after switch-on  
 Working temperature: -20°...60°C  
 Storage temperature: -20°...85°C  
 Protection: IP64 (front panel only)  
 El. safety: EN 61010-1, A2  
 Dielectric strength: 4 kVAC per 1 min test between supply and input  
 4 kVAC per 1 min test between supply and data/analog output  
 4 kVAC per 1 min test between input and relay output  
 2,5 kVAC per 1 min test between input and data/analog output  
 Insulation resistance: for pollution degree II, measuring cat. III  
 power supply > 670 V (PI), 300 V (DI)  
 input, output, PN > 300 V (PI), 150 V (DI)  
 EMC: EN 61326-1

PI - Primary insulation, DI - Double insulation

## CONNECTION

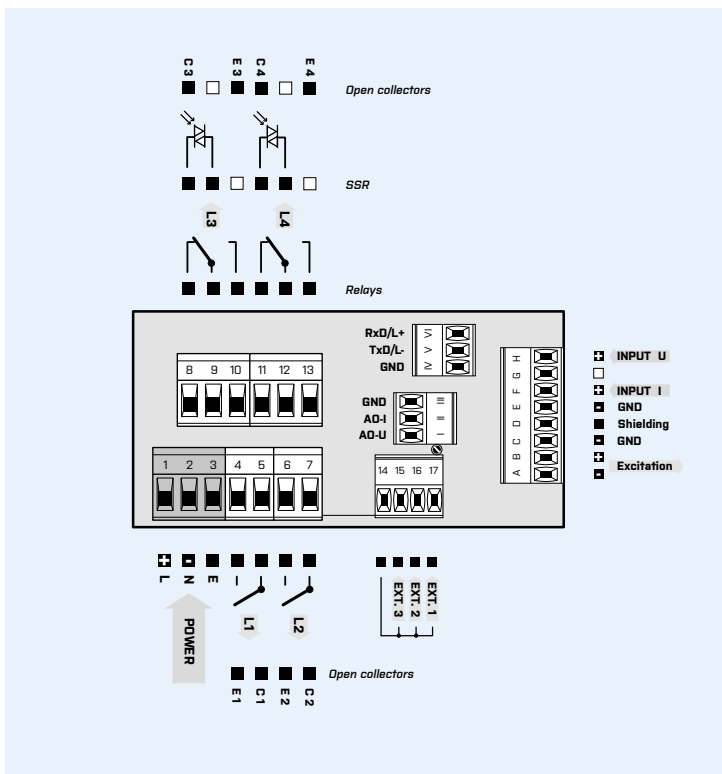

## ORDER CODE

<b>OM 5021</b>		- [ ] [ ] [ ] [ ] <b>1</b> [ ] [ ] - [ ]			
Power supply	10...30 V AC/DC 80...250 V AC/DC	<b>0</b> <b>1</b>			
Comparators	none 1x relay (Form A) 2x relay (Form A) 3x relays (2x Form A + 1x Form C) 4x relays (2x Form A + 2x Form C) 2x open collector 4x open collector 2x open collector + 2x relays (Form C) 2x relays (Form C) 2x SSR 2x bistable relays 1x relay (Form C)	<b>0</b> <b>1</b> <b>2</b> <b>3</b> <b>4</b> <b>5</b> <b>6</b> <b>7</b> <b>8</b> <b>9</b> <b>A</b> <b>B</b>			
Data output	none RS 232 RS 485 MODBUS* PROFIBUS	<b>0</b> <b>1</b> <b>2</b> <b>3</b> <b>4</b>			
Analog output	no yes (compensation < 600 Ω/12 V) yes (compensation < 1 000 Ω/24 V)	<b>0</b> <b>1</b> <b>2</b>			
Excitation	yes		<b>1</b>		
Data record	no RTC FAST		<b>0</b> <b>1</b> <b>2</b>		
Display color	red green			<b>1</b> <b>2</b>	
Specification	customized version, do not fill in				<b>00</b>

Basic configuration of the instrument is indicated in bold.

\* Unavailable in combination with RTC/FAST