



DISPLAY FOR STRAIN GAUGES

- 5-DIGIT PROGRAMMABLE PROJECTION
- RANGE: 1..4/2..8/4..16 mV/V
- WEIGHING FUNCTION, DIGITAL FILTERS, TARE
- ACCURACY: 0,05 %, RATE: 100 MEAS./S
- SIZE OF DIN 96 x 48 MM
- POWER SUPPLY 10...30 V AC/DC; 80...250 V AC/DC
- Option
Comparators • Data output • Analog output
Data record

OPERATION

The instrument is set and controlled by five buttons located on the front panel. All programmable settings of the instrument may be performed in three adjusting modes:

LIGHT MENU is protected by optional number code and contains solely items necessary for instrument setting.

PROFI MENU is protected by optional number code and contains complete instrument setting.

USER MENU may contain arbitrary items from the programming menu (LIGHT/PROFI), which determine the right (see, change). Access w/o password.

Standard equipment is the OM Link interface, which together with operation program enables modification and filing of all instrument settings as well as performing firmware updates (with OML cable). The program is also designed for visualization and filing of measured values from more instruments.

All settings are stored in the EEPROM memory (settings hold even after the instrument is switched off). The measured units may be projected on the display.

OPTION

COMPARATORS are assigned to monitor one, two, three or four limit values with relay output. As a user you can select the mode limit: LIMIT/BATCH/FROM-TO. The limits have adjustable hysteresis within the full range of the display as well as selectable delay of the switch-on in the range of 0...99,9 s. Reaching the preset limits is signalled by LED and simultaneously by the switch-on of the relevant relay.

DATA OUTPUTS are for their rate and accuracy suitable for transmission of the measured data for further projection or directly into the control systems. We offer an isolated RS232 and RS485 with the ASCII/PROFIBUS protocols.

ANALOG OUTPUTS will find their place in applications where further evaluating or processing of measured data is required in external devices. We offer universal analog output with the option of selection of the type of output - voltage/current. The value of analog output corresponds with the displayed data. Its type and range are selectable in menu.

MEASURED DATA RECORD is an internal time control of data collection. It is suitable where it is necessary to register measured values. Two modes may be used. FAST is designed for fast storage (40 records/s) of all measured values up to 8 000 records. Second mode is RTC, where Data record is governed by Real Time with data storage in a selected time segment and cycle. Up to 266 000 values may be stored in the instrument memory. Data transmission into PC via serial interface RS232/485 and OM Link.

OM 502T

Type OM 502T is a precision programmable panel display for strain gauges supplemented by weighing functions.

The instrument is based on a single-chip microcontroller with a fast 24-bit sigma-delta converter, which secures high accuracy, stability and easy operation of the instrument.

OM 502T

DISPLAY FOR STRAIN GAUGES

STANDARD FUNCTIONS

PROGRAMMABLE PROJECTION

Calibration: manual - setting sensitivity and maximum measuring range of the sensor

automatic - setting limit values of the measuring range using reference load

Weighing function: signalization of stabilized equilibrium, zero stabilization, automatic zero monitoring, defined number of segments on the scale

Selection of segment size: 0,001/.../0,1/0,2/0,5/1/2/5/10/20/50/100 (Mode - WEIGHT)

Projection: ±99999 (Mode - Standard)

EXCITATION

Fixed: 10 VDC, load ≥ 80 Ω

FUNCTIONS

Linearization: linear interpolation in 50 points (only via OM Link)

Min./max. value: registration of min./max. value reached during measurement

Tare: designed to reset display upon non-zero input signal

Fixed tare: firmly preset tare

Peak value: the display shows only max. or min. value

Mathemat. operations: polynom, 1/x, logarithm, exponential, power, root, sin x

DIGITAL FILTERS

Floating average: from 2...30 measurements

Exponential average: from 2...100 measurements

Arithmetic average: from 2...100 measurements

Rounding: setting the projection step for display

EXTERNAL CONTROL

Lock: control keys blocking

Hold: display/instrument blocking

Tare: tare activation

Resetting MM: resetting min./max. value

TECHNICAL DATA

INPUT

T Range	optional in configuration menu 1..4 mV/V 2..8 mV/V 4..16 mV/V
Excitation	10 VDC, load $\geq 80 \Omega$
Connect.	6-wire
Segment size	0.001/0.002/0.005/0.01/0.02/0.05/0.1/0.2/0.5/1/2/5/ 10/20/50/100
Zero monitoring	in 4% of the measuring range zero equals automatically, however on condition that the correction may not be greater than 0,5 segm./second
Automat. zero reset	if for the period of > 5 s there is a stabilized negative value on the display (when function Tare is active), tare is automatically cleared
Ext. inputs	3 inputs, on contact The following functions can be assigned: OFF input off HOLD display stop LDCK control keys blocking PASS. menu access blocking TARE tare activation CL. TA. tare resetting CL. M.M. resetting min/max value SAVE data recording start (FAST/RTC) CL. ME. data recording reset (FAST/RTC) CHAN. A. value display „Channel A“ FIL. A. value display „Channel A“ + filter MAT. FN. value display „Math. functions“

PROJECTION

Display: 99999...999999, single color 14-segment LED;
Digit height: 14 mm
Display color: red or green
Description: the last two characters on the display can be used to describe the measured quantities
Decimal point: adjustable - in menu
Brightness: adjustable - in menu

INSTRUMENT ACCURACY

TK: 50 ppm/°C
Accuracy: $\pm 0,05\%$ of range + 1 digit (for projection 99999 and 10 m/s)
Rate: 1..100 measur./s
Overload capacity: 2x; 10x (t < 30 ms)
Linearization: linear interpolation in 50 points (only via OM Link)
Digital filters: Exp./Floating/Arithm. average, Rounding
Functions: Offset, Min/max value, Tare, Peak value, Mat. operations
Data record: measured data record into instrument memory
RTC - 15 ppm/°C, time-date-display value < 266k data
FAST - display value < 8k data
Watch-dog: reset after 400 ms
OM Link: Company communication interface for operation, setting and update of instruments
Calibration: at 25°C and 40 % r.h.

COMPARATOR

Type: digital, menu adjustable, contact switch-on < 30 ms
Hysteresis mode: switching limit, hysteresis band „Lim $\pm 1/2$ Hys.“ and time (0..99,9 s) determining the switching delay
Mode From-To: switching on and switching off interval
Mode Batch: period, its multiples and time (0 ... 99,9 s), within which the output is active
Output: 1..2x relays Form A (250 VAC/30 VDC, 3 A) and 1..2x relays Form C (250 VAC/50 VDC, 3 A);
2x/4x open collector (30 VDC/100 mA); 2x SSR (250 VAC/ 1 A);
2x bistable relays (250 VAC/250 VDC, 3 A/0,3 A)

DATA OUTPUTS

Protocol: ASCII, MESSBUS, MODBUS RTU, PROFIBUS DP
Data format: 8 bit + no parity + 1 stop bit (ASCII)
7 bit + even parity + 1 stop bit (Messbus)
Rate: 600...230 400 Baud
9 600 Baud...12 Mbaud (PROFIBUS)
RS 232: isolated
RS 485: isolated, addressing (max. 31 instruments)

ANALOG OUTPUTS

Type: isolated, programmable with a 16-bit D/A converter, output type and range are optional in the menu
Non-linearity: 0,1% of range
TK: 15 ppm/°C
Rate: response to change of value < 1 ms
Ranges: 0..2/5/10 V, ± 10 V, 0..5 mA, 0/4...20 mA (comp. < 600 Ω /12 V or 1 000 Ω /24 V)

POWER SUPPLY

Range: 10...30 V AC/DC, $\pm 10\%$, PF $\geq 0,4$, $I_{STP} < 40$ A/1 ms, isolated
80...250 V AC/DC, $\pm 10\%$, PF $\geq 0,4$, $I_{STP} < 40$ A/1 ms, isolated
Consumption: < 8,0 W/7,8 VA
Power supply is protected by a fuse inside the instrument.

MECHANIC PROPERTIES

Material: Noryl GFN2 BE1, incombustible UL 94 V-1
Dimensions: 96 x 48 x 120 mm (w x h x d)
Panel cutout: 90,5 x 45 mm (w x h)

OPERATING CONDITIONS

Connection: connector terminal blocks, section < 1,5/2,5 mm²
Stabilization period: within 15 minutes after switch-on
Working temperature: -20°...60°C
Storage temperature: -20°...85°C
Protection: IP64 (front panel only)
El. safety: EN 61010-1, A2
Dielectric strength: 4 kVAC per 1 min test between supply and input
4 kVAC per 1 min test between supply and data/analog output
4 kVAC per 1 min test between input and relay output
2,5 kVAC per 1 min test between input and data/analog output
Insulation resistance: for pollution degree II, measuring cat. III
input, output, PN > 300 V (PI), 150 V (DI)
EMC: EN 61326-1

PI - Primary insulation, DI - Double insulation

CONNECTION

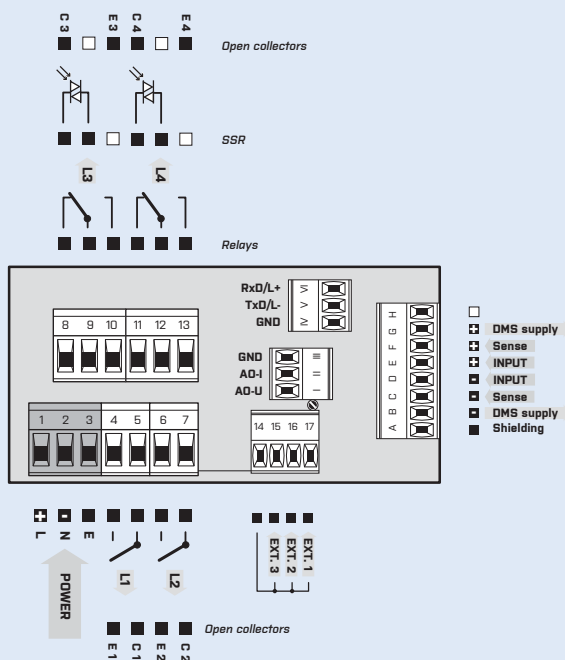

ORDER CODE

OM 502T

Power supply	10...30 V AC/DC 80...250 V AC/DC	0								
Comparators	none 1x relay (Form A) 2x relay (Form A) 3x relays [2x Form A + 1x Form C] 4x relays [2x Form A + 2x Form C] 2x open collector 4x open collector 2x open collector + 2x relays (Form C) 2x relays (Form C) 2x SSR 2x bistable relays 1x relay (Form C)	0 1 2 3 4 5 6 7 8 9 A B								
Data output	none RS 232 RS 485 MODBUS* PROFIBUS	0 1 2 3 4								
Analog output	no yes (compensation < 600 Ω /12 V) yes (compensation < 1 000 Ω /24 V)	0 1 2								
Data record	no RTC FAST	0 1 2								
Display color	red green	1 2								
Specification	customized version, do not fill in									00

Basic configuration of the instrument is indicated in bold.

* Unavailable in combination with RTC/FAST