

OM 502T

Type OM 502T is a precision programmable panel display for strain gauges supplemented by weighing functions.

The instrument is based on a single-chip microcontroller with a fast 24-bit sigma-delta converter, which secures high accuracy, stability and easy operation of the instrument..



DISPLAY FOR STRAIN GAUGES

- 5-digit programmable projection
- Range: 1...4/2...8/4...16 mV/V
- Weighing function, Digital filters, Tare
- Accuracy: 0,05 %, Rate: 100 meas./s
- Size of DIN 96 x 48 mm
- Power supply 10...30 V AC/DC; 80...250 V AC/DC
- Option
Comparators • Data output • Analog output • Data record

OM 502T
DISPLAY FOR STRAIN GAUGES

OPERATION

The instrument is set and controlled by five buttons located on the front panel. All programmable settings of the instrument may be performed in three adjusting modes:

LIGHT MENU is protected by optional number code and contains solely items necessary for instrument setting.

PROFI MENU is protected by optional number code and contains complete instrument setting.

USER MENU may contain arbitrary items from the programming menu (LIGHT/PROFI), which determine the right (see, change). Access w/o password.

Standard equipment is the OM Link interface, which together with operation program enables modification and filing of all instrument settings as well as performing firmware updates (with OML cable). The program is also designed for visualization and filing of measured values from more instruments.

All settings are stored in the EEPROM memory (settings hold even after the instrument is switched off). The measured units may be projected on the display.

OPTION

COMPARATORS are assigned to monitor one, two, three or four limit values with relay output. As a user you can select the mode limit: LIMIT/BATCH/FROM-TO. The limits have adjustable hysteresis within the full range of the display as well as selectable delay of the switch-on in the range of 0...99,9 s. Reaching the preset limits is signalled by LED and simultaneously by the switch-on of the relevant relay.

DATA OUTPUTS are for their rate and accuracy suitable for transmission of the measured data for further projection or directly into the control systems. We offer an isolated RS232 and RS485 with the ASCII/PROFIBUS protocols.

ANALOG OUTPUTS will find their place in applications where further evaluating or processing of measured data is required in external devices. We offer universal analog output with the option of selection of the type of output - voltage/current. The value of analog output corresponds with the displayed data. Its type and range are selectable in menu.

MEASURED DATA RECORD is an internal time control of data collection. It is suitable where it is necessary to register measured values. Two modes may be used. FAST is designed for fast storage (40 records/s) of all measured values up to 8 000 records. Second mode is RTC, where Data record is governed by Real Time with data storage in a selected time segment and cycle. Up to 266 000 values may be stored in the instrument memory. Data transmission into PC via serial interface RS232/485 and OM Link.

STANDARD FUNCTIONS

PROGRAMMABLE PROJECTION

Calibration: manual - setting sensitivity and maximum measuring range of the sensor

automatic - setting limit values of the measuring range using reference load

Weighing function: signalization of stabilized equilibrium, zero stabilization, automatic

zero monitoring, defined number of segments on the scale

Selection of segment size: 0,001.../0,1/0,2/0,5/1/2/5/10/20/50/100

(Mode - WEIGHT)

Projection: ±99999 (Mode - Standard)

EXCITATION

Fixed: 10 VDC, load ≥ 80 Ω

FUNCTIONS

Linearization: non-linear signals can be linearized by the means of a linearization table (up to 50 points)

Min./max. value: registration of min./max. value reached during measurement

Tare: designed to reset display upon non-zero input signal

Fixed tare: firmly preset tare

Peak value: the display shows only max. or min. value

Mathemat. operations: polynom, 1/x, logarithm, exponential, power, root, sin x

DIGITAL FILTERS

Floating average: from 2...30 measurements

Exponential average: from 2...100 measurements

Arithmetic average: from 2...100 measurements

Rounding: setting the projection step for display

EXTERNAL CONTROL

Lock: control keys blocking

Hold: display/instrument blocking

Tare: tare activation

Resetting MM: resetting min./max. value

TECHNICAL DATA

INPUT

Number of inputs	1
T Range	optional in configuration menu
	1...4 mV/V
	2...8 mV/V
	4...16 mV/V
Excitation	10 VDC, load $\geq 80 \Omega$
Connection	6-wire
Segment size	0.001/0.002/0.005/0.01/0.02/0.05/0.1/0.2/0.5/1/2/5/10/20/50/100
Zero monitoring	in 4% of the measuring range zero equals automatically, however on condition that the correction may not be greater than 0.5 segments/second
Automat. zero reset	if for the period of > 5 s there is a stabilized negative value on the display (when function Tare is active), tare is automatically cleared
Ext. inputs	3 inputs, on contact
	The following functions can be assigned:
	OFF input off
	HOLD display stop
	LOCK control keys blocking
	PASS. menu access blocking
	TARE tare activation
	CL. TA. tare resetting
	CL. M.M. resetting min/max value
	SAVE data recording start (FAST/RTC)
	CL. ME. data recording reset (FAST/RTC)
	CHAN. A. value display „Channel A“
	FIL. A. value display „Channel A“ + filter
	MAT. FN. value display „Math. functions“

PROJECTION

Display: -99999...999999, single color 14-segment LED;
 Digit height: 14 mm
 Display color: red or green
 Description: the last two characters on the display can be used to describe the measured quantities
 Decimal point: adjustable - in menu
 Brightness: adjustable - in menu

INSTRUMENT ACCURACY

TC: 50 ppm/°C
 Accuracy: $\pm 0.05\%$ of range + 1 digit (for projection 99999 and 10 meas./s)
 Rate: 1...100 measurement/s
 Overload capacity: 2x; 10x (t < 30 ms)
 Linearization: linear interpolation in 50 points (only via OM Link)
 Digital filters: Exp/Floating/Arithm. average, Rounding
 Functions: Offset, Min/max value, Tare, Peak value, Mat. operations
 Data record: measured data record into instrument memory
 RTC - 15 ppm/°C, time-date-display value < 266k data
 FAST - display value < 8k data
 Watch-dog: reset after 400 ms
 OM Link: Company communication interface for operation, setting and update of instruments
 Calibration: at 25°C and 40 % r.h.

COMPARATOR

Type: digital, menu adjustable, contact switch-on < 30 ms
 Hysteresis mode: switching limit, hysteresis band (Lim and $\pm 1/2$ Hys.) and time (± 99.9 s) determining the switching delay
 Mode From-To: switching on and switching off interval
 Mode Batch: period, its multiples and time (0...99.9 s), within which the output is active
 Output: 1..2x relays Form A (250 VAC/30 VDC, 3 A) and 1..2x relays Form C (250 VAC/50 VDC, 3 A);
 2x/4x open collector (30 VDC/100 mA); 2x SSR (250 VAC/1 A);
 2x bistable relays (250 VAC/250 VDC, 3 A/0.3 A)

DATA OUTPUTS

Protocol: ASCII, MESSBUS, MODBUS RTU, PROFIBUS DP
 Data format: 8 bit + no parity + 1 stop bit (ASCII)
 7 bit + even parity + 1 stop bit (Messbus)
 Rate: 600...230 400 Baud
 9 600 Baud...12 Mbaud (PROFIBUS)
 RS 232: isolated
 RS 485: isolated, addressing (max. 31 instruments)

ANALOG OUTPUTS

Type: isolated, programmable with a 16-bit D/A converter, output type and range are optional in the menu
 Non-linearity: 0.1% of range
 TC: 15 ppm/°C
 Rate: response to change of value < 1 ms
 Ranges: 0...2.5/10 V, ± 10 V, 0...5 mA, 0/4...20 mA (comp. < 600 Ω /12 V or 1 000 Ω /24 V)

POWER SUPPLY

Range: 10...30 V AC/DC, $\pm 10\%$, PF ≥ 0.4 , I_{STP} < 40 A/1 ms, isolated
 80...250 V AC/DC, $\pm 10\%$, PF ≥ 0.4 , I_{STP} < 40 A/1 ms, isolated
 Consumption: < 8.0 W/7.8 VA
 Power supply is protected by a fuse inside the instrument.

MECHANIC PROPERTIES

Material: Noryl GFN2 SE1, incombustible UL 94 V-1
 Dimensions: 96 x 48 x 120 mm (w x h x d)
 Panel cutout: 90.5 x 45 mm (w x h)

OPERATING CONDITIONS

Connection: connector terminal blocks, section < 1.5/2.5 mm²
 Stabilization period: within 5 minutes after switch-on
 Working temperature: -20°...60°C
 Storage temperature: -20°...85°C
 Protection: IP64 (front panel only)
 El. safety: EN 61010-1, A2
 Dielectric strength: 4 kVAC per 1 min test between supply and input
 4 kVAC per 1 min test between supply and data/analog output
 4 kVAC per 1 min test between input and relay output
 2.5 kVAC per 1 min test between input and data/analog output
 Insulation resistance: for pollution degree II, measuring cat. III
 power supply > 670 V (PI), 300 V (DI)
 input, output, PN > 300 V (PI), 150 V (DI)
 EMC: EN 61326-1

PI - Primary insulation, DI - Double insulation

CONNECTION

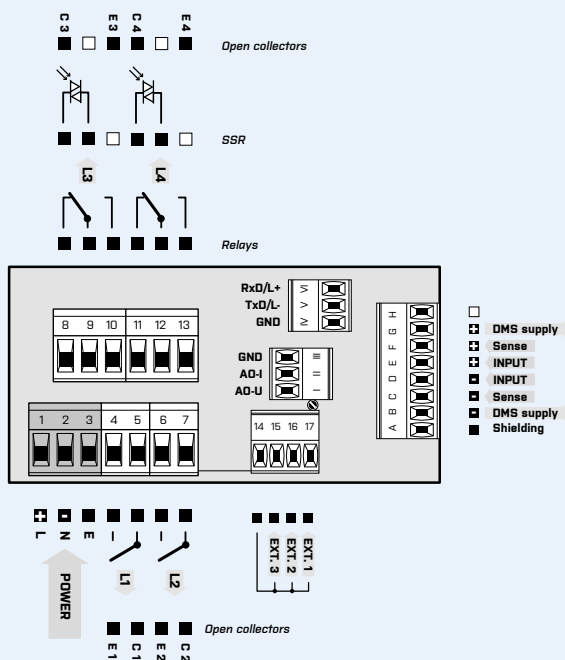

ORDER CODE

OM 502T

Power supply	10...30 V AC/DC	0						
	80...250 V AC/DC	1						
Comparators	none	0						
	1x relay (Form A)	1						
	2x relay (Form A)	2						
	3x relays (2x Form A + 1x Form C)	3						
	4x relays (2x Form A + 2x Form C)	4						
	2x open collector	5						
	4x open collector	6						
	2x open collector + 2x relays (Form C)	7						
	2x relays (Form C)	8						
	2x SSR	9						
2x bistable relays	A							
1x relay (Form C)	B							
Data output	none	0						
	RS 232	1						
	RS 485	2						
	MODBUS* PROFIBUS	3 4						
Analog output	no		0					
	yes (compensation < 600 Ω /12 V)		1					
	yes (compensation < 1 000 Ω /24 V)		2					
Data record	no		0					
	RTC		1					
	FAST		2					
Display color	red			1				
	green			2				
Specification	customized version, do not fill in							00

Basic configuration of the instrument is indicated in bold.

* Unavailable in combination with RTC/FAST