

OM 602UQC



OM 602UQC UNIVERSAL COUNTER

- 6-digit programmable projection
- 2x counter UP/DOWN, 2x IRC
- Mat.functions, Digital filter, Tare, Preset, Sum
- Size of DIN 96 x 48 mm
- Power supply 80...250 V AC/DC



Options

- Excitation • Comparators • Data output • Analog output • Data record
- Time backup • Power supply: 10...30 V AC/DC

Data outputs are for their rate and accuracy suitable for transmission of the measured data for further projection or directly into the control systems. We offer an isolated RS232 and RS485 with the ASCII/MESSBUS/MODBUS/PROFIBUS protocol.

Analog outputs will find their place in applications where further evaluating or processing of measured data is required in external devices. We offer universal analog output with the option of selection of the type of output - voltage/current. The value of analog output corresponds with the displayed data and its type and range are selectable in menu.

Measured data record is an internal time control of data collection. It is suitable where it is necessary to register measured values. Two modes may be used. FAST is designed for fast storage (80 records/s) of all measured values up to 8 000 records. Second mode is RTC, where data record is governed by Real Time with data storage in a selected time segment and cycle. Up to 130 000 values may be stored in the instrument memory. Data transmission into PC via serial interface RS232/485 and OM Link.

Time backup is suitable where time needs to be measured even in case of supply voltage outage (upon power supply outage the instrument does not display)

Description

OM 602UQC is a universal 6 digit panel programmable dual-channel impulse counter/frequency meter/evaluation of signal from IRC sensors and timer/clock.

The instrument is based on an 8-bit processor that secures high accuracy, stability and easy operation of the instrument.

Operation

The instrument is set and controlled by five control keys located on the front panel. All programmable settings of the instrument may be performed in three adjusting modes:

Light menu is protected by optional number code and contains solely items necessary for instrument setting

Profi menu is protected by optional number code and contains complete instrument setting

User menu may contain arbitrary items from the programming menu (LIGHT/PROFI), which determine the right (see, change). Access w/o password.

Standard equipment is the OM Link interface, which together with operation program enables modification and filing of all instrument settings as well as perform firmware updates (with OML cable). The program is also designed for visualization and filing of measured values from more instruments.

All settings are stored in the EEPROM memory (they hold even after the instrument is switched off).

The measured units may be projected on the display.

Options

Excitation is suitable for feeding of sensors and transmitters. It is isolated, with continuously adjustable value in the range of 5...24 VDC.

Comparators are assigned to monitor one, two, three or four limit values with relay output. The user may select limits regime: LIMIT/DOSING/FROM-TO. The limits have adjustable hysteresis within the full range of the display as well as selectable delay of the switch-on in the range of 0...99,9 s. Reaching the preset limits is signalled by LED and simultaneously by the switch-on of the relevant relay.

Standard functions

PROGRAMMABLE PROJECTION

Input: NPN, PNP, upon contact, IRC, line

Measuring modes: counter/frequency/UP-DW counter + frequency/counter for IRC

Calibration: calibration coefficient for each channel may be set in menu independently

Projection: -99999...999999 with fixed or floating DP in format 10/24/60

Measuring channels: A and B, from one or more measuring inputs two independent functions may be evaluated

Time base: 0,05/0,5/1/2/5/10/20/50/100 s

LINEARIZATION

Linearization: by linear interpolation in 50 points (solely via OM Link)

FUNCTIONS

Preset: initial non-zero value, which is always read after resetting the instrument to zero

Summation: registration of the number upon shift operation

Pre-division constant: 1...999999

DIGITAL FILTERS

Filtration constant (UC): transmits input signal up to 10...2 000 Hz

Floating/Exp./Arithmetic average: from 2...30/100/100 measurements

Rounding: setting the projection step for display

MATHEMATIC FUNCTIONS

Min/max. value: registration of min/max. value reached during measurement

Tare: designed to reset display upon non-zero input signal

Peak value: the display shows only max. or min. value

Mat. operations: polynome, 1/x, logarithm, exponential, power, root, sin x and at the same time between inputs - sum, difference, product, quotient

EXTERNAL CONTROL

Lock control keys blocking

Hold display/instrument blocking

Tare tare activation

Resetting MM resetting min/max value

Start/Stop: stopwatch/timer control

Technical data

PROJECTION

Display: -9999...99999, red or green 14-segment LED, digit height 14 mm

Decimal point: setting - in menu
Brightness: setting - in menu

INSTRUMENT ACCURACY

TC: 50 ppm/°C

Accuracy: ±0,01% of range + 1 digit

Input frequency: 0,02...800 000 Hz (400 kHz - for IRC)

Measuring mode: 2x UP or DW counter + frequency, UP/DW counter for IRC + frequency

Input filters: Filtration constant, Rounding, Digital filters

Time base: 0,05...50 s

Calibration constant: 0,00001...999999

Filtration constant: 0/2,5/5/12,5/100 ms

PRESET: 0...999999

Pre-division constant: 1/10/60/100/1000/3600

Digital filters: Exp./Floating/Arithmetic average, Rounding

Functions: Preset, Sum, Data backup, Min/max value, Tare, Peak value, Mathematic operations

Ext. control: HOLD, LOCK, Tare, Resetting to zero

Data record: measured data record into instrument memory

RTC - 15 ppm/°C, time-date-display value, < 130k data

FAST - display value, < 8k data

Watch-dog: reset after 0,4 s

OM Link: Company communication interface for operation, setting and update of instruments

Calibration: at 25°C and 40% r.h.

COMPARATOR

Type: digital, setting in prog. mode, contact switch < 30 ms

Limits: -99999...999999

Hysteresis: 0...999999

Delay: 0...99,9 s

Output: 2x relays Form A (250 VAC/30 VDC, 3 A) and 2x Form C relays (250 VAC/50 VDC, 3 A), 2x/4x open collectors, 2x SSR, 2x bistable relays

DATA OUTPUT

Protocol: ASCII, MESSBUS, MODBUS - RTU, PROFIBUS

Data format: 8 bit + no parity + 1 stop bit

7 bit + even parity + 1 stop bit (Messbus)

Rate: 600...115 200 Baud

9 600 Baud...12 Mbaud (PROFIBUS)

RS 232: isolated

RS 485: isolated, addressing (max. 31 instruments)

ANALOG OUTPUT

Type: isolated, programmable with resolution of max. 10 000 points, AO corresponds with the displayed data, type and range are selectable in programming mode

Non-linearity: 0,2% of range

TC: 100 ppm/°C

Rate: response to change of value < 40 ms

Ranges: 0...2/5/10 V, 0...5 mA, 0/4...20 mA (comp. < 500 Ω/12 V or 1 000 Ω/24 V)

EXCITATION

Adjustable: 5...24 VDC/max. 1,2 W

POWER SUPPLY

10...30 V AC/DC, ±10%, max. 13,5 VA

80...250 V AC/DC, ±10%, max. 13,5 VA

Power supply is protected by a fuse inside the instrument

MECHANICAL PROPERTIES

Material: Noryl GFN2 SE1, incombustible UL 94 V-I

Dimensions: 96 x 48 x 120 mm

Panel cutout: 90,5 x 45 mm

OPERATING CONDITIONS

Connection: connector terminal board, section < 2,5 mm²

Stabilization period: within 15 minutes after switch-on

Working temperature: 0°...60°C

Storage temperature: -10°...85°C

Cover: IP65 (front panel only)

El. safety: EN 61010-1, A2

Insulation resistance: for pollution degree II, measuring cat. III.

power supply > 670 V (PI), 300 V (DI)

input, output, Exc. > 300 V (PI), 150 V (DI)

EMC: EN 61000-3-2+A12; EN 61000-4-2, 3, 4, 5, 8, 11;

EN 550222, A1, A2

Seismic capacity: IEC 980: 1993, par. 6

PI - Primary insulation, DI - Double insulation

Connection

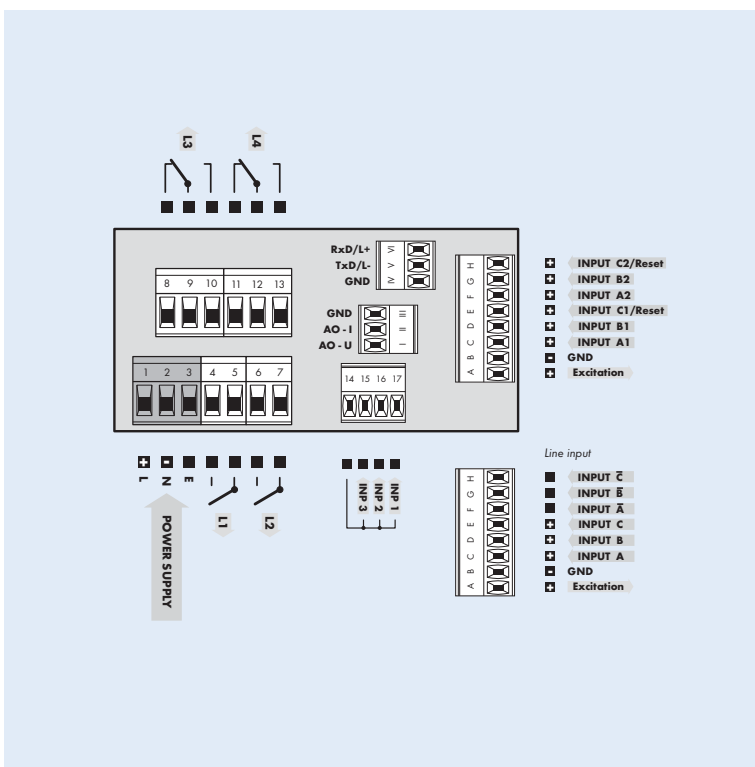

Order code

OM 602UQC*		-									
Power supply	10...30 V AC/DC 80...250 V AC/DC	0 1									
Input	2x standard line	A C									
Comparators	none 1x relay (Form A) 2x relays (Form A) 3x relays (2x Form A + 1x Form C) 4x relays (2x Form A + 2x Form C) 2x open collector 4x open collector 2x open collector + 2x relays (Form C) 2x relays (Form C) 2x SSR 2x bistable relays 1x relay (Form C)	0 1 2 3 4 5 6 7 8 9 A B									
Data output	no RS 232 RS 485 MODBUS PROFIBUS	0 1 2 3 4									
Analog output	no yes (compensation < 500 Ω/12 V) yes (compensation < 1 000 Ω/24 V)	0 1 2									
Time backup	no yes	0 1									
Excitation	no yes	0 1									
Data record	no RTC FAST	0 1 2									
Display color	red green	1 2									

* Scheduled for distribution 1.Q/2008