



- 6-DIGIT PROGRAMMABLE PROJECTION
- 2x COUNTER UP/DOWN, 2X IRC
- MAT. FUNCTION, DIGITAL FILTER, TARE, PRESET, SUM
- SIZE OF DIN 96 x 48MM
- POWER SUPPLY 80...250 V AC/DC
- Option
 - Comparators • Data output • Analog output • Data record
 - Power supply 10...30 V AC/DC

OM 602UQC

OMLINK

OM 602UQC is a universal 6-digit panel programmable dual-channel impulsecounter/frequency meter/evaluation of signal from IRC sensors and timer/clock.

The instrument is based on a single chip microprocessor and a powerful programmable gate array which guarantees high accuracy, stability and easy control.

OM 602UQC
DUAL UNIVERSAL COUNTER

OPERATION

The instrument is set and controlled by five control keys located on the front panel. All programmable settings of the instrument may be performed in three adjusting modes:

LIGHT MENU is protected by optional number code and contains solely items necessary for instrument setting

PROFI MENU is protected by optional number code and contains complete instrument setting

USER MENU may contain arbitrary items from the programming menu (LIGHT/PROFI), which determine the right (see, change). Access w/o password.

Standard equipment is the OM Link interface, which together with operation program enables modification and filing of all instrument settings as well as perform firmware updates (with OML cable). The program is also designed for visualization and filing of measured values from more instruments.

All settings are stored in the EEPROM memory (they hold even after the instrument is switched off). The measured units may be projected on the display.

OPTION

COMPARATORS are assigned to monitor one, two, three or four limit values with relay output. The user may select limits regime: LIMIT/DOSING/FROM-TO. The limits have adjustable hysteresis within the full range of the display as well as selectable delay of the switch-on in the range of 0...99,9 s. Reaching the preset limits is signalled by LED and simultaneously by the switch-on of the relevant relay.

DATA OUTPUTS are for their rate and accuracy suitable for transmission of the measured data for further projection or directly into the control systems. We offer an isolated RS232 and RS485 with the ASCII/MESSBUS/MODBUS/PROFIBUS protocol.

ANALOG OUTPUTS will find their place in applications where further evaluating or processing of measured data is required in external devices. We offer universal analog output with the option of selection of the type of output - voltage/current. The value of analog output corresponds with the displayed data and its type and range are selectable in menu.

MEASURED DATA RECORD is an internal time control of data collection. It is suitable where it is necessary to register measured values. Mode RTC, where data record is governed by Real Time with data storage in a selected time segment and cycle. Up to 266 000 values may be stored in the instrument memory. Data transmission into PC via serial interface RS232/485 and OM Link.

STANDARD FUNCTIONS

PROGRAMMABLE PROJECTION

Input: NPN, PNP, upon contact, IRC, line, SSI

Measuring mode: counter/frequency/UP-DW counter + frequency/counter for IRC

Calibration: calibration coefficient for each channel may be set in menu independently

Projection: -99999...999999 with fixed or floating DP in format 10/24/60

Measuring channels: A and B, from one or more measuring inputs two independent functions may be evaluated

Time base: 0,05/0,5/1/2/5/10/20 s/1/2/5/10/15 min

EXCITATION

Range: 5...24 VDC, for feeding of sensors and transmitters

LINEARIZATION

Linearization: through linear interpolation in 50 points (solely via OM Link)

FUNCTIONS

Preset: initial non-zero value, which is always read after resetting the instrument to zero

Summation: registration of the number upon shift operation

Pre-division constant: 1...999999

Time backup: is suitable where time needs to be measured even in case of supply voltage outage (upon power supply outage the instrument does not display)

DIGITAL FILTERS

Filtration constant: transmits input signal up to 1 MHz...10 min

Floating/Exp./Arithmetic average: from 2...30/100/100 measurements

Rounding: setting the projection step for display

MATHEMATIC FUNCTIONS

Min/max. value: registration of min/max. value reached during measurement

Tare: designed to reset display upon non-zero input signal

Peak value: the display shows only max. or min. value

Mat. operations: polynome at the same time between inputs - sum, difference, product, quotient

EXTERNAL CONTROL

Lock: control keys blocking

Hold: display/instrument blocking

Tare: tare activation

Resetting MM: resetting min/max value, counter resetting

Start/Stop: stopwatch/timer control

TECHNICAL DATA

PROJECTION

Display: 99999...999999, red or green 14-segment LED, digit height 14 mm
Decimal point: setting - in menu
Brightness: setting - in menu

INSTRUMENT ACCURACY

TK: 50 ppm/°C
Accuracy: ±0,01% of range + 1 digit
Overload capacity: 2x; 10x (t < 30 ms)
Measuring mode: 2x UP or DW counter + frequency, UP/DW counter for IRC + frequency
Input frequency: 0,002 Hz...1 MHz (500 kHz - pro IRC)
Input filters: Filtration constant, Rounding, Digital filters
Time base: 0,05 s...15 min
Calibration constant: 0,00001...999999
Filtration constant: 1 MHz...10 min
PRESET: 0...999999
Divide constant: 1...999999
Digital filters: Exp./Floating/Arithmetic average, Rounding
Functions: Preset, Sum, Data backup, Min/max value, Tare, Peak value., Mathematic operations
Ext. control: HOLD, LOCK, Tare, Resetting to zero
Data record: measured data record into instrument memory
RTC: - 15 ppm/°C, time-date-display value, < 266k data
Watch-dog: reset after 0,4 s
DM Link: Company communication interface for operation, setting and update of instruments
Calibration: at 25°C and 40% r.h.

COMPARATOR

Type: digital, setting in menu, contact switch < 10 ms (without filtration < 50 µs)
Limits: 99999...999999
Hysteresis: 0...999999
Delay: 0...99,9 s
Output: 2x relays Form A [250 VAC/30 VDC, 3 A] and 2x Form C relays [250 VAC/50 VDC, 3 A], 2x/4x open collectors, 2x SSR, 2x bistable relays

DATA OUTPUT

Protocol: ASCII, MESSBUS, MODBUS - RTU, PROFIBUS
Data format: 8 bit + no parity + 1 stop bit (ASCII)
 7 bit + even parity + 1 stop bit (Messbus)
Rate: 600...230 400 Baud
 9 600 Baud...12 Mbaud (PROFIBUS)
RS 232: Isolated
RS 485: Isolated, addressing (max. 31 instruments)

ANALOG OUTPUT

Type: isolated, programmable with 16-bit D/A converter, type and range are selectable in programming mode
Non-linearity: 0,1% of range
TK: 15 ppm/°C
Rate: response to change of value < 1 ms
Ranges: 0...2/5/10 V, ±10 V, 0...5 mA, 0/4...20 mA (comp. < 600 Q/12 V or 1 000 Q/24 V)

EXCITATION

Adjustable: 5...24 VDC/max. 1,2 W

POWER SUPPLY

10...30 V AC/DC, ±10%, max 13,5 VA, PF≥0,4, I_{STP}< 40 A/1 ms
 80...250 V AC/DC, ±10%, max. 13,5 VA, PF≥0,4, I_{STP}< 40 A/1 ms
 Power supply is protected by a fuse inside the instrument

MECHANICAL PROPERTIES

Material: Noryl GFN2 SE1, incombustible UL 94 V-1
Dimensions: 96 x 48 x 120 mm
Panel cutout: 90,5 x 45 mm

OPERATING CONDITIONS

Connection: connector terminal board, section < 1,5/2,5 mm²
Stabilization period: within 15 minutes after switch-on
Working temperature: -20°...60°C
Storage temperature: -20°...85°C
Cover: IP64 (front panel only)
El. safety: EN 61010-1, A2
Dielectric strength: 4 kVAC after 1 min between supply and input
 4 kVAC after 1 min between supply and data/analog output
 4 kVAC after 1 min between supply and relay output
 2,5 kVAC after 1 min between input and data/analog output
Insulation resistance: for pollution degree II, measuring cat. III.
 Power supply > 670 V (ZI), 300 V (DI)
 input, output, Exc. > 300 V (ZI), 150 V (DI)
EMC: EN 61326-1
Seismic capacity: IEC 980: 1993, par. 6

PI - Primary insulation, DI - Double insulation

MEASURING RANGES

OM 602 is a multifunction instrument available in following types

UQC: 0...60 V, comparison levels are adjustable in the menu
 input frequency 0,002 Hz...1 MHz (500 kHz for QUADR and UP/DW)

Measuring modes for channel 1 and 2

SINGLE Counter/Frequencymeter
A * B Counter/Frequencymeter with function AND
xNDR Counter/Frequencymeter with function NOR
DUTY Duty
QUADR Counter/Frequencymeter for IRC sensors
UP/DW UP/DW Counter/Frequencymeter
 - used in inputs A, B (direction) and can display count/frequency
UP - DW UP - DW Counter/Frequencymeter
 - used in inputs A (UP), B (DW) and can display count/frequency
TIME Stopwatch
RTC Timer

ORDER CODE SPECIFICATION

UQC	
A	standard, contact, TTL, NPN/PNP, input: 25 mV...60 V
B	Synchronous serial interface (SSI)
C	Line input

CONNECTION

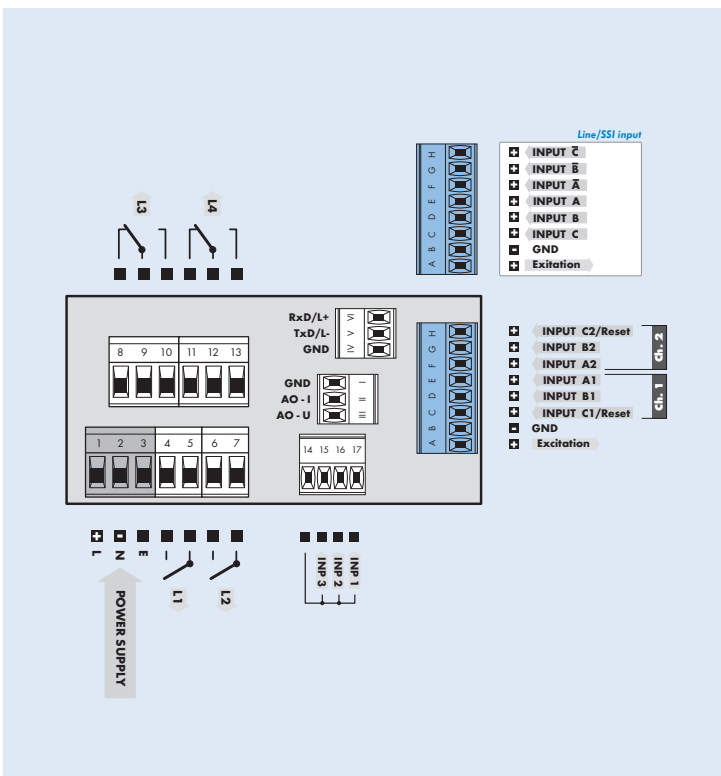

ORDER CODE

OM 602UQC

		- [] [] [] [] [] [] [] [] [] [] [] -									
Power supply	10...30 V AC/DC	0									
	80...250 V AC/DC	1									
Input	2x standard (10 mV...60 V)	A									
	Synchronous serial interface (SSI)*	B									
	line	C									
Comparators	none	0									
	1x relay (Form A)	1									
	2x relays (Form A)	2									
	3x relays (2x Form A + 1x Form C)	3									
	4x relays (2x Form A + 2x Form C)	4									
	2x open collectors	5									
	4x open collectors	6									
	2x open collectors + 2x relays (Form C)	7									
	2x relays (Form C)	8									
	2x SSR	9									
2x bistable relays	A										
1x relay (Form C)	B										
Data output	none	0									
	RS 232	1									
	RS 485	2									
	MODBUS PROFIBUS	3 4									
Analog output	no	0									
	yes [Compensation < 600 Q/12 V] yes [Compensation < 1 000 Q/24 V]	1 2									
Time backup Only for measuring mode „Watch“	yes							1			
Excitation	yes								1		
Data record	no									0	
	RTC									1	
Display color	red										1
	green										2
Other	customer version, do not fill in										00

Default execution is shown in bold

* Launch for sale has not been set