



- HORIZONTAL BARGRAPH - 30 LED WITH DISPLAY
- MULTIFUNCTION INPUT (DC, PM, RTD, T/C, DU)
- DIGITAL FILTERS, TARE, LINEARIZATION
- SIZE OF DIN 96 X 48 MM
- POWER SUPPLY 80...250 V AC/DC
- Option
 - Excitation • Comparators • Data output • Analog output
 - Data record • Power supply 10...30 V AC/DC

OPERATION

The instrument is set and controlled by five control keys located on the front panel. All programmable settings of the instrument may be performed in three adjusting modes:

LIGHT MENU is protected by optional number code and contains solely items necessary for instrument setting

PROFI MENU is protected by optional number code and contains complete instrument setting

USER MENU may contain arbitrary items from the programming menu (LIGHT/PROFI), which determine the right (see, change). Access w/o password.

Standard equipment is the OM Link interface, which together with operation program enables modification and filing of all instrument settings as well as perform firmware updates (with OML cable). The program is also designed for visualization and filing of measured values from more instruments.

All settings are stored in the EEPROM memory (they hold even after the instrument is switched off).

OPTION

EXCITATION is suitable for feeding of sensors and transmitters. It is isolated, with continuously adjustable value in the range of 5...24 VDC.

COMPARATORS are assigned to monitor one, two, three or four limit values with relay output. The user may select limits regime: LIMIT/DOSING/FROM-TD. The limits have adjustable hysteresis within the full range of the display as well as selectable delay of the switch-on in the range of 0...99,9 s. Reaching the preset limits is signalled by LED and simultaneously by the switch-on of the relevant relay.

DATA OUTPUTS are for their rate and accuracy suitable for transmission of the measured data for further projection or directly into the control systems. We offer an isolated RS232 and RS485 with the ASCII/MESSBUS/MODBUS/PROFIBUS protocol.

ANALOG OUTPUTS will find their place in applications where further evaluating or processing of measured data is required in external devices. We offer universal analog output with the option of selection of the type of output - voltage/current. The value of analog output corresponds with the displayed data and its type and range are selectable in menu.

MEASURED DATA RECORD is an internal time control of data collection. It is suitable where it is necessary to register measured values. Two modes may be used. FAST is designed for fast storage (40 records/s) of all measured values up to 8 000 records. Second mode is RTC, where data record is governed by Real

OMB 402

OMLINK

The OMB 402 model series are panel programmable three-color bar graphs with auxiliary display designed for maximum efficiency and user comfort while maintaining its favourable price. Three versions are available: UNI, PWR and UQC.

The OMB 402UNI is a multifunction instrument with the option of configuration for 8 various input options, easily configurable in the instrument menu.

The instrument is based on an 8-bit microcontroller with a multichannel 24-bit sigma-delta converter, which secures high accuracy, stability and easy operation of the instrument.

OMB 402UNI

DC VOLTMETER AND AMMETER
 PROCESS MONITOR
 OHMMETER
 THERMOMETER FOR Pt/Cu/Ni/Termocouples
 DISPLAY UNIT FOR LINEAR POTENTIOMETERS

OMB 402PWR

AC VOLTMETER AND AMMETER
 AC NETWORK ANALYSER

OMB 402UQC

UNIVERSAL COUNTER

Time with data storage in a selected time segment and cycle. Up to 266 000 values may be stored in the instrument memory. Data transmission into PC via serial interface RS232/485 and OM Link.

STANDARD FUNCTIONS

PROGRAMMABLE PROJECTION

Selection: of input type and measuring range

Measuring range: adjustable as fixed or with automatic change (OHM)

Measuring modes (PWR): voltage (V_{RMS}), current (A_{RMS}), real power (W), frequency (Hz) and with calculation of Q, S, cos fi

Setting (UQC): measuring mode 2x counter (UP/DW, IRC)/2x frequency/timer/clock with adjustable calibration coefficient, time base and projection

Setting: manual, in menu optional projection on the display may be set for both limit values of the input signal

Projection: 30 LED + 6-digit auxiliary display

COMPENSATION

Of conduct (RTD, OHM): automatic (3- and 4-wire) or manual in menu (2-wire)

of conduct in probe (RTD): internal connection (conduct resistance in measuring head)
of CJC (T/C): manual or automatic, in menu it is possible to perform selection of the type of thermocouple and compensation of cold junctions, which is adjustable or automatic

LINEARIZATION

Linearization (DC, PM, DU): through linear interpolation in 50 points (solely via OM Link)

DIGITAL FILTERS

Filtration constant (UQC): transmits input signal up to 10...2 000 Hz

Floating/Exp./Arithmetic average: from 2...30/100/100 measurements

Rounding: setting the projection step for display

MATHEMATIC FUNCTIONS

Min/max. value: registration of min/max. value reached during measurement

Tare: designed to reset display upon non-zero input signal

Peak value: the display shows only max. or min. value

Mat. operations: polynome, 1/x, logarithm, exponential, power, root, sin x and at the same time between inputs - sum, difference, product, quotient

EXTERNAL CONTROL*

Lock: control keys blocking

Hold: display/instrument blocking

Tare: tare activation

Resetting MM: resetting min/max value

TECHNICAL DATA

PROJECTION

Display: 30 three-color LED with 6 digit aux.display [-99999...999999], digit height 9,1 mm
Decimal point: setting - in menu
Brightness: setting - in menu

INSTRUMENT ACCURACY

TK: 50 ppm/°C
Accuracy: ±0,1% of range + 1 digit [for projection 9999 and 5 meas./s] ±0,15% of range + 1 digit **RTD, T/C**
 ±0,3% [0,6/0,9 %] of range + 1 digit **PWR**
Accuracy of cold junction measurement: ±1,5°C
Rate: 0,1..40 meas./s, 0,5..5 meas./s [PWR]
Overload capacity: 10x [t < 30 ms] - not for > 250 V and 5 A; 2x
Measuring modes [PWR]: voltage (V_{RMS}), current (A_{RMS}), real power (W), frequency (Hz) and with calculation of Q, S, cos φ
Linearization: by linear interpolation in 50 points
Time base [UQC]: 0,05..50 s
Calibration constant [UQC]: 0,00001..999999
Filtration constant [UQC]: 0/10/20/45/65/..1000/2000 Hz
PRESET [UQC]: 0..999999
Digital filters: Exp/Floating/Arithmetic average, Rounding
Functions: Offset, Min/max, hod., Tare, Peak value, Mat. operations
Ext. control: HOLD, LOCK, Tare, Reset
Data record: measured data record into instrument memory
RTC: - 15 ppm/°C, time-date-display value, < 266k data
FAST [UNI] - display value, < 8k data
Watch-dog: reset after 0,4 s
OM Link: Company communication interface for operation, setting and update of instruments
Calibration: at 25°C and 40 % r.h.

COMPARATOR

Type: digital, setting in menu, contact switch < 30 ms
Limits: -99999...999999
Hysteresis: 0..999999
Delay: 0..99,9 s
Output: 2x relays Form A [250 VAC/30 VDC, 3 A] and 2x Form C relays [250 VAC/50 VDC, 3 A], 2x/4x open collectors, 2x SSR, 2x bistable relays

DATA OUTPUT

Protocol: ASCII, MESSBUS, MODBUS - RTU, PROFIBUS
Data format: 8 bit + no parity + 1 stop bit [ASCII]
 7 bit + even parity + 1 stop bit [Messbus]
Rate: 600..230 400 Baud
 9 600 Baud..12 Mbaud [PROFIBUS]
RS 232: isolated
RS 485: isolated, addressing [max. 31 instruments]

ANALOG OUTPUT

Type: isolated, programmable with 12-bit D/A converter, type and range are selectable in programming mode
Non-linearity: 0,1% of range
TK: 15 ppm/°C
Rate: response to change of value < 1 ms
Ranges: 0..2/5/10 V, ±10 V, 0..5 mA, 0/4..20 mA [comp. < 500 Q/12 V or 1 000 Q/24 V]

EXCITATION

Adjustable: 5..24 VDC/max. 1,2 W

POWER SUPPLY

10..30 V AC/DC, ±10 %, max. 13,5 VA, PF≥0,4, I_{STP}< 40 A/1 ms
 80..250 V AC/DC, ±10 %, max. 13,5 VA, PF≥0,4, I_{STP}< 40 A/1 ms
Power supply is protected by a fuse inside the instrument

MECHANIC PROPERTIES

Material: Noryl GFN2 SEI, incombustible UL 94 V-1
Dimensions: 96 x 48 x 120 mm
Panel cutout: 90,5 x 45 mm

OPERATING CONDITIONS

Connection: connector terminal board, section < 1,5/2,5 mm²
Stabilization period: within 15 minutes after switch-on
Working temperature: -20°..60°C
Storage temperature: -20°..80°C
Cover: IP64 (front panel only)
El. safety: EN 61010-1, A2
Dielectric strength: 4 kVAC after 1 min between supply and input 4 kVAC after 1 min between supply and data/analog output 4 kVAC after 1 min between supply and relay output 2,5 kVAC after 1 min between input and data/analog output
Insulation resistance: for pollution degree II, measuring cat. III. Power supply > 670 V [Zi], 300 V [Di] input, output, Exc. > 300 V [Zi], 150 V [Di]
EMC: EN 61326-1
Seismic capacity: IEC 980: 1993, par. 6
SW validation [UNI]: Class B, C in compliance with IEC 62138, 61226

PI - Primary insulation, DI - Double insulation

MEASURING RANGES

OMB 402 is a multifunction instrument available in following types and ranges

type UNI, standard [code „0“]

DC: ±60/±150/±300/±1 200 mV
PM: 0..5 mA/0..20 mA/4..20 mA/±2 V/±5 V/±10 V/±40 V
OHM: 0..100 Q/0..1 kQ/0..10 kQ/0..100 kQ
RTD: Pt 100/Pt 500/Pt 1 000
Cu: Cu 50/Cu100
Ni: Ni 1 000/Ni 10 000
T/C: J/K/T/E/B/S/R/N/L
DU: Linear potentiometer [min. 500 Q]

type UNI, Option A

DC: ±0,1/±0,25/±0,5/±2/±5 A/±100 V/±250 V/±500 V

type PWR

input U: 0..10 V/0..120 V/0..250 V/0..450 V
input I: 0..60 mV/0..150 mV/0..300 mV/0..1 A/0..2,5 A/0..5 A

type UQC

Measuring mode [UQC]: input frequency 0,002 Hz..1 MHz [500 kHz for QUADR and UP/DW]
 2x UP or DW counter, UP or DW counter + frequency, UP/DW counter, UP/DW counter for IRC + frequency, timer/clock/phase

CONNECTION

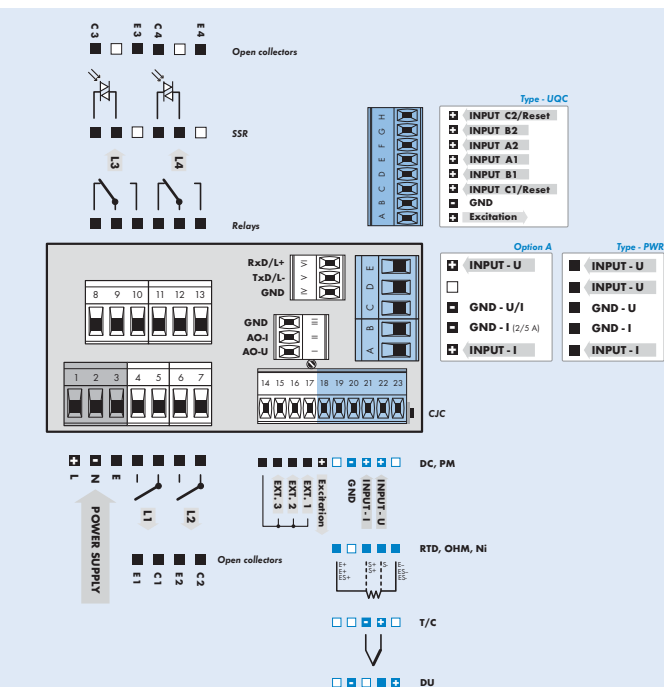

*GND (input + Option A) is galvanically connected with inputs EXT. and the OM Link connector
 *In case of Option B we recommend to connect terminals GND (main board/additional board) by external connection

CONNECTING INDIVIDUAL INPUTS

	INPUT „I“	INPUT „U“
DC		±60/±150/±300/±1200 mV
PM	0..5/0..20 mA/4..20 mA	±2/±5/±10/40 V

ORDER CODE SPECIFICATION

	UNI	PWR - U	PWR - I	UQC
w/o	standard			
A	±0,1/±0,25/±0,5/±2/±5 A ±100/±250/±500 V			standard contact, TTL, NPN/PNP
B	Expansion about three inputs (PM)			SSI input
C				line input
K			0..60/150/300 mV	
P			0..1/2,5/5 A	
S		0..10/120 V		
U		0..250/450 V		
Z	on request	on request	on request	

ORDER CODE

OMB 402

Type	U	N	I	P	W	R*	U	Q	C*
Order code shall not include blank spaces!									
Power supply	10..30 V AC/DC	80..250 V AC/DC	0	1					
Option, see table „Order code specification“			?						
Comparators	none	1x relay (Form C)	2x relays (Form C)	3x relays (Form C)	4x relays (Form C)	2x open collectors	4x open collectors	2x open collectors + 2x relays (Form C)	2x relays (Form C)
			SSR	2x bistabilní relays	1x relay (Form C)				
Analog output	no	yes [Compensation < 500 Q/12 V]	yes [Compensation < 1 000 Q/24 V]				0	1	2
Data output	none	RS 232	RS 485	MODBUS	PROFIBUS		0	1	2
Excitation	no	yes					0	1	
Data record	no	RTC	FAST [only for UNI]				0	1	2
Colour of digital display	red	green							1
Other	customer version, do not fill in	SW validation - IEC 62138, IEC 61226							00
									VS

For complete technical parameters of OMB 402UQC see the universal counter OM 602UQC

Default execution is shown in bold

* Launch for sale has not been set