

OMB 451UNI



The OMB 451 model series are panel programmable three-color bargraphs with auxiliary display and adjustable LCD scale.

Type OMB 451UNI is a multifunction instrument with the option of configuration for 8 various input options, easily configurable in the instrument menu.

The instrument is based on a single-chip microcontroller with multichannel 24-bit sigma-delta converter, which secures high accuracy, stability and easy operation of the instrument.

UNIVERSAL BARGRAPH

- Bargraf - 50 LED with display and LCD scale
- Multifunction input (DC, PM, RTD, T/C, DU)
- Digital filters, Tare, Linearization
- Size of DIN 160 x 60 mm
- Power supply 10...30 V AC/DC; 80...250 V AC/DC
- Option
 - Comparators • Data output • Analog output • Measured data record

OMB 451UNI

DC VOLTMETER AND AMMETER
 PROCESS MONITOR
 OHMMETER
 THERMOMETER FOR Pt/Cu/Ni/THERMOCOUPLES
 DISPLAY UNIT FOR LINEAR POTENTIOMETERS

OPERATION

The instrument is set and controlled by two control keys and a turn knob located on the front panel. All programmable settings of the instrument may be performed in three adjusting modes:

LIGHT MENU is protected by optional number code and contains solely items necessary for instrument setting.

PROFI MENU is protected by optional number code and contains complete instrument setting.

USER MENU may contain arbitrary items from the programming menu (LIGHT/PROFI), which determine the right (see, change). Access w/o password.

Standard equipment is the OM Link interface, which together with operation program enables modification and filing of all instrument settings as well as performing firmware updates (with OML cable). The program is also designed for visualization and filing of measured values from more instruments.

All settings are stored in the EEPROM memory (settings hold even after the instrument is switched off).

OPTION

COMPARATORS are assigned to monitor four or eight limit values with relay output. For each input the user may select an arbitrary number of relays with the regime: LIMIT/BATCH/FROM-TO. The limits have adjustable hysteresis within full range of the display and selectable delay of the switch-on within the range of 0...99 s. Reaching the preset limits is signalled by LED and simultaneously by the switch-on of the relevant relay.

DATA OUTPUTS are for their rate and accuracy suitable for transmission of the measured data for further projection or directly into the control systems. We offer an isolated RS232 and RS485 with the ASCII/MESSBUS/MODBUS/PROFIBUS protocol.

ANALOG OUTPUTS will find their place in applications where further evaluating or processing of measured data is required in external devices. We offer universal analog output with the option of selection of the type of output - voltage/current and the option of assigning it to arbitrary input. The value of analog output corresp. with the displayed data and its type and range are selectable in menu.

MEASURED DATA RECORD is an internal time control of data collection. It is suitable where it is necessary to register measured values. Two modes may be used. FAST is designed for fast storage (40 records/s) of all measured values up to 8 000 records. Second mode is RTC, where data record is governed by Real Time with data storage in a selected time segment and cycle. Up to 266 000 values may be stored in the instrument memory. Data transmission into PC via serial interface RS 232/485 and OM Link.

STANDARD FUNCTIONS

PROGRAMMABLE PROJECTION

Selection: of input type and measuring range

Measuring range: adjustable, either fixed or with automatic change (OHM)

Setting: manual, optional projection on the display may be set in menu for both limit values of the input signal, e.g. input 0...10,00 V > 0...850.0

Projection: 50 LED + 6-digit auxiliary display

Scale: LCD, freely programmable

EXCITATION

Range: 5...24 VDC/1,2 W, for feeding sensors and transmitters

COMPENSATION

Of conduct (RTD, OHM): automatic (3- or 4-wire) or manual in menu (2-wire)

Of conduct in probe (RTD): internal connection (conduct resistance in measuring head)

Of CJC (T/C): manual or automatic, in menu it is possible to perform selection of the type of thermocouple and compensation of cold junctions, which is adjustable or automatic (temperature of terminals)

FUNCTIONS

Linearization: non-linear signals can be linearized by the means of a linearization table (up to 50 points)

Tare: designed to reset display upon non-zero input signal

Min./max. value: registration of min./max. value reached during measurement

Peak value: the display shows only max. or min. value

Mathemat. operations: polynom, 1/x, logarithm, exponential, power, root, sin x, and operations between inputs - sum, difference

DIGITAL FILTERS

Floating average: from 2...30 measurements

Exponential average: from 2...100 measurements

Arithmetic average: from 2...100 measurements

Rounding: setting the projection step for display

EXTERNAL CONTROL

Lock: control keys blocking

Hold: display/instrument blocking

Tare: tare activation

Resetting MM: resetting min/max value

TECHNICAL DATA

INPUT	
Number of inputs	1
DC Range	optional in configuration menu ±60 mV > 100 MΩ Input U ±150 mV > 100 MΩ Input U ±300 mV > 100 MΩ Input U ±1 200 mV > 100 MΩ Input U
PM Range	optional in configuration menu 0...20 mA < 400 mV Input I 4...20 mA < 400 mV Input I ±2 V 1 MΩ Input U ±5 V 1 MΩ Input U ±10 V 1 MΩ Input U ±40 V 1 MΩ Input U
OHM Range	optional in configuration menu with autorange 0...100 Ω 0...1 kΩ 0...10 kΩ 0...100 kΩ
Connection	2, 3 or 4 wire
Pt Type	optional in configuration menu EU > 100/500/1 000 Ω, 3 850 ppm/°C -50°...450°C US > 100 Ω, 3 920 ppm/°C -50°...450°C RU > 50 Ω, 3 910 ppm/°C -200°...1100°C RU > 100 Ω, 3 910 ppm/°C -200°...450°C
Connection	2, 3 or 4 wire
Ni Type	optional in configuration menu Ni 1 000/10 000 with 5 000 ppm/°C -50°...250°C Ni 1 000/10 000 with 6 180 ppm/°C -50°...250°C
Connection	2, 3 or 4 wire
Cu Type	optional in configuration menu Cu 50/100 with 4 260 ppm/°C -50°...200°C Cu 50/100 with 4 280 ppm/°C -200°...200°C
Connection	2, 3 or 4 wire
T/C Type	optional in configuration menu J (Fe-CuNi) -200°...900°C K (NiCr-Ni) -200°...1 300°C T (Cu-CuNi) -200°...400°C E (NiCr-CuNi) -200°...690°C B (PtRh30-PtRh6) 300°...1 820°C S (PtRh10-Pt) -50°...1 760°C R (Pt13Rh-Pt) -50°...1 740°C N (Omegalloy) -200°...1 300°C L (Fe-CuNi) -200°...900°C
DU P. supply	2 VDC/6 mA, Potentiometer resistance > 500 Ω
Ext. inputs	3 inputs, on contact The following functions can be assigned: OFF / HOLD / LOCK / PASS. / TARE / CL. TA. / CL. MM. / SAVE / CL. ME. / CHAN. A. / FIL. A. / MAT. FN. / SWITCH.

OPTION „A“	
DC Range	optional in configuration menu ±0.1 A < 300 mV Input I ±0.25 A < 300 mV Input I ±0.5 A < 300 mV Input I ±1 A < 30 mV Input I ±5 A < 150 mV Input I ±100 V 20 MΩ Input U ±250 V 20 MΩ Input U ±500 V 20 MΩ Input U
OPTION „B“	
Number of inputs	3
PM Range	optional in configuration menu 0...20 mA < 400 mV Input 2, 3, 4 - I 4...20 mA < 400 mV Input 2, 3, 4 - I ±2 V 1 MΩ Input 2, 3, 4 - U ±5 V 1 MΩ Input 2, 3, 4 - U ±10 V 1 MΩ Input 2, 3, 4 - U ±40 V 1 MΩ Input 2, 3, 4 - U

PROJECTION
Bargraph display: 50 + 50 LED
 upper row displays the input value, the lower indicates the set limits
Bar color: red/green/orange
Scale: LCD backlight and freely programmable
Auxiliary display: -99999...999999, single color 7-segment LED
Digit height: 9,1 mm
Display color: red or green
Description: the last two characters on the display can be used to describe the measured quantities
Decimal point: adjustable - in menu
Brightness: adjustable - in menu

INSTRUMENT ACCURACY
TC: 50 ppm/°C
Accuracy: ±0.1% of range + 1 digit (for proj. 9999 and 5 measur./s)
 ±0.15% of range + 1 digit **RTD, T/C**
Accuracy of cold junction measur.: ±1.5°C
Rate: 0.1..40 measurement/s
Overload capacity: 2x; 10x (t < 30 ms) - not for > 250 V and 5 A
Resolution (RTD, T/C): 1/10/0.1/0.01°C
Line compensation: max. 30 Ω (RTD)
Cold junction compens.: adjustable -20°...99°C or automatic
Linearization: linear interpolation in 50 points (only via OM Link)
Digital filters: Exp./Floating/Arithm. average, Rounding
Functions: Offset, Min/max value, Tare, Peak value, Mat. operations
Data record: measured data record into instrument memory
 RTC - 15 ppm/°C, time-date-display value < 266k data
 FAST - display value < 8k data
OM Link: company communication interface for operation, setting and update of instruments
Watch-dog: reset after 400 ms
Calibration: at 25°C and 40% r.h.

COMPARATOR
Type: digital, menu adjustable, contact switch-on < 30 ms
Hysteresis mode: switching limit, hysteresis band (Lim and ±1/2 Hys.) and time (±99.9 s) determining the switching delay
Mode From-To: switching on and switching off interval
Mode Batch: period, its multiples and time (0...99.9 s), within which the output is active
Output: 1...4x relays Form C (250 VAC/50 VDC, 3 A);
 2x/4x open collector (30 VDC/100 mA)

DATA OUTPUTS
Protocol: ASCII, MESSBUS, MODBUS RTU, PROFIBUS DP
Data format: 8 bit + no parity + 1 stop bit (ASCII)
 7 bit + even parity + 1 stop bit (Messbus)
Rate: 600...230 400 Baud, 0.0096...12 Mbaud (PROFIBUS)
RS 232: isolated
RS 485: isolated, addressing (max. 31 instruments)

ANALOG OUTPUTS
Type: isolated, programmable with a 16-bit D/A converter, output type and range are optional in the menu
Non-linearity: 0.1% of range
TC: 15 ppm/°C
Rate: response to change of value < 1 ms
Ranges: 0...2/5/10 V, ±10 V, 0...5 mA, 0/4...20 mA
 (comp. < 600 Ω/12 V or 1 000 Ω/24 V)

EXCITATION
Adjustable: 5...24 VDC/max. 1.2 W

POWER SUPPLY
Range: 10...30 V AC/DC, ±10%, PF ≥ 0.4, I_{typ} < 40 A/1 ms, isolated
 80...250 V AC/DC, ±10%, PF ≥ 0.4, I_{STP} < 40 A/1 ms, isolated
Consumption: < 15.5 W/15.5 VA
Power supply is protected by a fuse inside the instrument.

MECHANIC PROPERTIES
Material: Noryl GFN2 SE1, incombustible UL 94 V-1
Dimensions: 160 x 60 x 80 mm (w x h x d)
Panel cutout: 150 x 50 mm (w x h)

OPERATING CONDITIONS
Connection: connector terminal blocks, section < 1.5/2.5 mm²
Working temperature: -20°...60°C
Storage temperature: -20°...80°C
Protection: IP64 (front panel only)
El. safety: EN 61010-1, A2
Dielectric strength: 4 kVAC per 1 min test between supply and input
 4 kVAC per 1 min test between supply and data/analog output
 4 kVAC per 1 min test between input and relay output
 2.5 kVAC per 1 min test between input and data/analog output
Insulation resistance: for pollution degree II, measuring cat. III
 power supply > 670 V (PI), 300 V (DI)
 input, output, PN > 300 V (PI), 150 V (DI)
EMC: EN 61326-1
Seismic capacity: IEC 980: 1993, par. 6
SW validation: Class B, C in compl. with IEC 62138, 61226

PI - Primary insulation, DI - Double insulation

CONNECTION

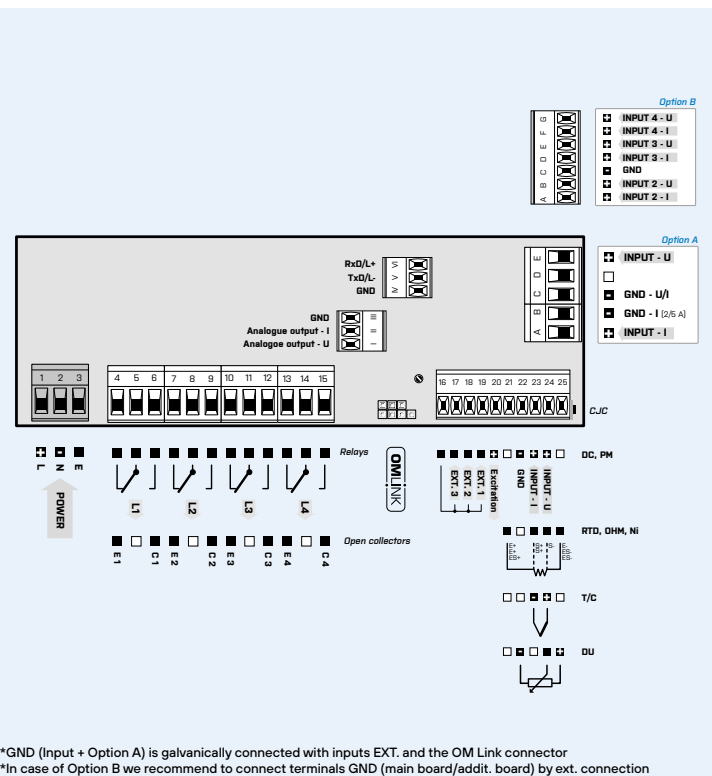

*GND (Input + Option A) is galvanically connected with inputs EXT. and the OM Link connector
 *In case of Option B we recommend to connect terminals GND (main board/addit. board) by ext. connection

ORDER CODE

OMB 451UNI		- [] [] [] [] [] [] [] [] [] [] [] [] [] [] - [] []	
Power supply	10...30 V AC/DC 80...250 V AC/DC	0	
Measuring range	standard option „A“ option „B“	1	
Comparators	no 1x relay (Form C) 2x relays (Form C) 3x relays (Form C) 4x relays (Form C) 2x open collector 4x open collector	0 1 2 3 4 5 6	
Analog output	no yes (compensation < 600 Ω/12 V) yes (compensation < 1000 Ω/24 V)	0 1 2	
Data output	no RS 232 RS 485 MODBUS* PROFIBUS	0 1 2 3 4	
Excitation	yes	1	
Data record	no RTC FAST	0 1 2	
Display color	red (14 mm) green (14 mm)	1 2	
Specification	customized version, do not fill in SW validation - IEC 62138, IEC 61226		00 VS

Basic configuration of the instrument is indicated in bold.

* Unavailable in combination with RTC/FAST