



- THREE-COLOR BARGRAPH 20/30/50 LED
- MULTIFUNCTION INPUT (PM, OHM, RTD, DU)
- DIGITAL FILTERS, LINEARIZATION
- POWER SUPPLY 10...30 V AC/DC
- Option
Comparators

OMB 200/300/500

OMLINK

The OMB 200/300/500UNI model series are simple bargraphs designed for maximum efficiency and user comfort while maintaining its low cost.

The OMB 200/300/500UNI type is a multifunction instrument with the option of configuration for 5 different types of inputs easily configurable in the instrument menu.

The instrument is based on an 8-bit microcontroller with A/D converter, which secures good accuracy, stability and easy operation of the instrument.

Another version of the OMB 200/300/500 instrument is the RS type, a display device for projection of data from serial line RS 232/485.

By selecting the mode of insertion of the front plexiglass (reverse/face) you may choose the required printing of scale for vertical or horizontal design of the instrument.

OMB 200/300/500UNI

PROCESS MONITOR
OHMMETER
THERMOMETER FOR Pt/Ni
DISPLAY UNIT FOR LINEAR POTENTIOMETERS

OMB 200/300/500RS

DATA DISPLAY

OPERATION

The instrument is set and controlled by five control keys located on the front panel. All programmable settings of the instrument may be performed in two adjusting modes:

PROFI MENU contains complete instrument setting

Standard equipment is the OM Link interface, which together with operation program enables modification and filing of all instrument settings as well as perform firmware updates (with OML cable).

All settings are stored in the EEPROM memory (they hold even after the instrument is switched off).

OPTION

COMPARATORS are assigned to monitor two limit values with relay output. The limits have adjustable hysteresis within the full range of the display as well as selectable delay of the switch-on in the range of 0...99,9 s. Reaching the preset limits is signalled by LED and simultaneously by the switch-on of the relevant relay.

STANDARD FUNCTIONS

PROGRAMMABLE PROJECTION

Selection: of input type and measuring range

Setting: manual, in menu optional projection on the display may be set for both limit values of the input signal

Projection: 20, 30 or 50 LED

LINEARIZATION

Linearization: through linear interpolation in 25 points (solely via OM Link)

DIGITAL FILTERS

Exponential average: from 2...100 measurements

Rounding: setting the projection step for display

EXTERNAL CONTROL*

Hold: display/instrument blocking

Lock: control keys blocking

TECHNICAL DATA

PROJECTION

Display: three-color LED (red/green/orange)
 OMB 200 - 20 LED
 OMB 300 - 30 LED
 OMB 500 - 50 LED
 OMB 502 - 2x 50 LED
Decimal point: setting - in menu
Brightness: setting - in menu

INSTRUMENT ACCURACY

TK: 50 ppm/°C
Accuracy: ±1% of range + 1 digit
Rate: 0,5/5/50/max. meas./s
Overload capacity: 10x (t < 30 ms); 2x
Watch-dog: reset after 20 ms
Functions: HOLD, LOCK, Digital filters
OM Link: Company communication interface for operation, setting and update of instruments
Calibration: at 25°C and 40 % r.h.

COMPARATOR

Type: digital, setting in menu, contact switch-on < 50 ms
Limits: within full range
Hysteresis: positive values
Delay: 0...99,9 s
Output: 1(2)x bistable relays (250 VAC/30 VDC, 3 A),
 1(2)x relays Form A (250 VAC/50 VDC, 3 A) only for OMB 500/502

POWER SUPPLY

10...30 V DC/24 VAC, ±10 %, 3 VA, PF ≥ 0,4, I_{STP} < 45 A/1,1 ms
 10...30 V AC/DC, ±10 %, max. 10 VA, PF ≥ 0,4, I_{STP} < 45 A/1,1 ms
 [only for OMB 500/2]
 80...250 V AC/DC, ±10 %, max. 10 VA, PF ≥ 0,4, I_{STP} < 45 A/1,1 ms
 [only for OMB 500/2]
Power supply is protected by a fuse inside the instrument
 [only for OMB 500/502]

MECHANIC PROPERTIES

Material: Noryl GFN2 SE1, incombustible UL 94 V-1
Dimensions:
 OMB 200 72 x 24 x 100 mm
 OMB 300 96 x 24 x 100 mm
 OMB 500 144 x 48 x 75 mm
Panel cutout:
 OMB 200 68 x 22,5 mm
 OMB 300 92 x 22,5 mm
 OMB 500 138 x 43,5 mm

OPERATING CONDITIONS

Connection: connector terminal board, section < 1,5/2,5 mm²
Stabilization period: within 15 minutes after switch-on
Working temperature: -20°...60°C
Storage temperature: -20°...85°C
Cover: IP40 (front panel only)
El. safety: EN 61010-1, A2
Dielectric strength: 2,5 kVAC after 1 min between supply and input
Insulation resistance: for pollution degree II, measuring cat. III.
 Power supply > 300 V [Z]
 input, output > 300 V [Z], 150 V [D]
EMC: EN 61326-1

Pt - Primary insulation, DI - Double insulation

MEASURING RANGES

OMB 200/300/500UNI is a multifunction instrument available in following types and ranges

PM: 0...20 mA/4...20 mA/0...2 V/ 0...5 V/0...10 V
OHM: 0...100 kΩ
RTD: Pt 1 000/KTY/Termistor
Ni: Ni 1 000
DU: Linear potentiometer (min. 500 Ω), poze jeden input (1)

type OMB xxxRS

RS: input RS 232/RS 485, Protocol ASCII/MODBUS - RTU

CONNECTING INDIVIDUAL INPUTS

	INPUT 1	INPUT 2
DC	0...20 mA, 4...20 mA	0...2 V/0...5 V/0...10 V
OHM	0...100 kΩ	
RTD	Pt 1 000/KTY/Termistor	
Ni	Ni 1 000	
DU	Linear potentiometer (min. 500 Ω)	

CONNECTION

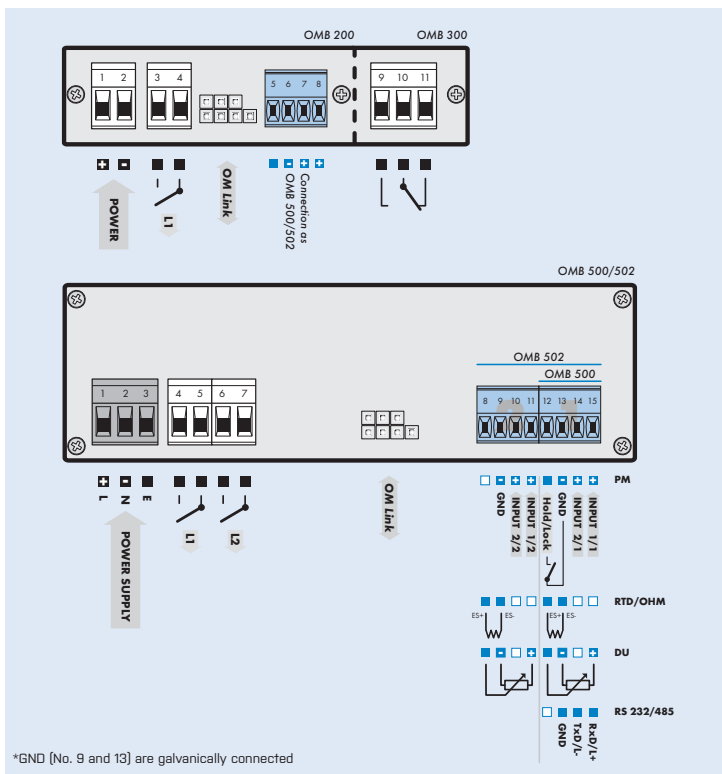

ORDER CODE

OMB **UNI** - -

Type	20 LED	2 0 0	•	
	30 LED	3 0 0	•	
	50 LED	5 0 0	•	
	2x 50 LED	5 0 2	•	
Power supply	10...30 V AC/DC	0 1		
	80...250 V AC/DC	1		
Comparators	no	0		
	1x relay	1		
	2x relays*	2		
Other	customer version, do not fill in			00

OMB **RS** - -

Type	20 LED	2 0 0	•	
	30 LED	3 0 0	•	
	50 LED	5 0 0	•	
	2x 50 LED	5 0 2	•	
Power supply	10...30 V AC/DC	0 1		
	80...250 V AC/DC	1		
Comparators	no	0		
	1x relay	1		
	2x relays*	2		
Other	customer version, do not fill in			00

* Only for OMB 300 and OMB 500/502

Default execution is shown in bold