

USER MANUAL

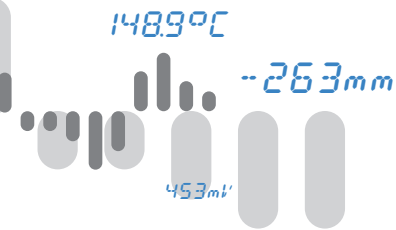

OM 402UNI

4 DIGIT PROGRAMMABLE
UNIVERSAL INSTRUMENT

DC VOLTmeter/AMMETER
PROCESS MONITOR
OHMMETER

THERMOMETER FOR Pt 100/500/1 000
THERMOMETER FOR Ni 1 000/10 000
THERMOMETER FOR THERMOCOUPLES
DISPLAYS FOR LIN. POTENTIOMETERS



Outstanding Measurement Value



SAFETY INSTRUCTIONS

Please read carefully the enclosed safety instructions and observe them!

Installation, all operational interventions, maintenance and service must be performed by a qualified personnel and in accordance with the attached information and safety regulations. The manufacturer is not liable for damage caused by improper installation, configuration, maintenance, and service.

The recorder must be installed according to the respective application. Incorrect installation can cause a malfunction, which can result in damage or accident.

The recorder uses dangerous voltages that can cause a fatal accident. Before you start solving problems (e.g. in case of failure or disassembly), the device must be disconnected from the power supply. For safety information the EN 61 010-1 + A2 standard must be observed.

When removing or inserting a card, observe the safety instructions and follow the recommended procedure. During any intervention the recorder must be disconnected from the power supply.

Do not attempt to repair or modify the device. A defective recorder must be sent for repair to the manufacturer. These devices should be safeguarded by isolated or common fuses (breakers)!

The recorder is not designed for installation in potentially explosive surroundings (Ex). Use it only outside potentially explosive surroundings

TECHNICAL DATA

Measuring instruments of the OM 402 series conform to the European regulation 2014/30/EU and 2014/35/EU

The instruments are up to the following European standards

EN 61010-1	Electrical safety
EN 61326-1	Electronic measuring, control and laboratory devices - Requirements for EMC "Industrial use"
IEC 980: 1993, Par. 6	Seismic resistance

The recorders are applicable for unlimited use in agricultural and industrial areas.

ORBIT MERRET, spol. s r.o.

Vodňanská 675/30
198 00 Praha 9
Czech republic

Tel: +420 - 281 040 200
Fax: +420 - 281 040 299
orbit@merret.eu
www.orbit.merret.eu



1. CONTENTS	3	6.3 "PROFI" menu - OUTPUT	
2. INSTRUMENT DESCRIPTION	4	6.3.1 Setting data logging	64
3. INSTRUMENT CONNECTION	6	6.3.2 Setting Limits	66
Measuring ranges.....	6	6.3.3 Setting data output.....	69
Termination of RS 485 communication line.....	6	6.3.4 Setting analog output.....	70
Instrument connection.....	7	6.3.5 Selection of display projection.....	72
Recommended connection of sensors	8	6.4 "PROFI" menu - SERVICE	
4. INSTRUMENT SETTING	10	6.4.1 Selection of programming menu	
Symbols used in the instructions	12	„LIGHT“/„PROFI“	74
Setting the DP and the (-) sign	12	6.4.2 Restoration manufacture setting	75
Control keys function.....	13	6.4.3 Calibration - input range (DU).....	75
Setting/permitting items into "USER" menu.....	13	6.4.4 Selection of instrument menu	
5. SETTING "LIGHT" MENU	14	language version	76
5.0 Description "LIGHT" menu	14	6.4.5 Setting new access password	76
Setting input - Type "DC"	18	6.4.6 Instrument identification	77
Setting input - Type "PM"	20	7. SETTING ITEMS INTO "USER" MENU	78
Setting input - Type "OHM".....	22	7.0 Configuration "USER" menu.....	78
Setting input - Type "RTD - Pt"	24	8. METHOD OF MEASURING OF THE COLD JUNCTION	80
Setting input - Type "RTD - Ni".....	26	9. DATA PROTOCOL	81
Setting input - Type "T/C"	28	10. ERROR STATEMENTS	82
Setting input - Type "DU"	30	11. TABLE OF SYMBOLS	83
Setting input - Type "RTD - Cu"	32	12. TECHNICAL DATA	84
Setting Limits.....	34	13. INSTRUMENT DIMENSIONS AND INSTALATION	86
Setting analog output	36	14. CERTIFICATE OF GUARANTEE	87
Selection of programming menu „LIGHT“/„PROFI"	38	DECLARATION OF CONFORMITY	88
Restoration of manufacture setting	38		
Calibration - input range (DU).....	39		
Selection of instrument menu language version.....	40		
Setting new access password	40		
Instrument identification	41		
6. SETTING "PROFI" MENU	42		
6.0 Description of "PROFI" menu.....	42		
6.1 "PROFI" menu - INPUT			
6.1.1 Resetting internal values	46		
6.1.2 Setting measuring type, range, mode, rate	47		
6.1.3 Setting the Real Time	51		
6.1.4 External input function selection	51		
6.1.5 Optional accessory functions of the keys.....	52		
6.2 "PROFI" menu - CHANNEL			
6.2.1 Setting measuring parameters (projection, filters, decimal point, description)	56		
6.2.2 Setting mathematic functions	60		
6.2.3 Selection of evaluation of min/max. value	62		

2. INSTRUMENT DESCRIPTION

2.1 DESCRIPTION

The OM 402 model series are 4 digit panel programmable instruments designed for maximum efficiency and user comfort while maintaining their favourable price. Two models are available: UNI and PWR.

Type OM 402UNI is a multifunction instrument with the option of configuration for 8 various input options, easily configurable in the instrument menu. By further options of input modules it is feasible to measure larger ranges of DC voltage and current or increase the number of inputs up to 4 (applies for PM).

The instrument is based on an 8-bit microcontroller with a multichannel 24-bit sigma-delta converter, which secures high accuracy, stability and easy operation of the instrument.

TYPES AND RANGES

UNI	DC:	0...60/150/300/1200 mV
	PM:	0...5 mA/0...20 mA/4...20 mA/A \pm 2 V/ \pm 5 V/ \pm 10 V/ \pm 40 V
	OHM:	0...100 Ω /0...1 k Ω /0...10 k Ω /0...100 k Ω /Autorange
	RTD-Pt:	Pt 50/100/Pt 500/Pt 1000
	RTD-Cu:	Cu 50/Cu 100
	RTD-Ni:	Ni 1 000/Ni 10 000
	T/C:	J/K/T/E/B/S/R/N/L
	DU:	Linear potentiometer (min. 500 Ω)
UNI - A	DC:	\pm 0,1 A/ \pm 0,25 A/ \pm 0,5 A/ \pm 2 A/ \pm 5 A/ \pm 100 V/ \pm 250 V/ \pm 500 V
UNI - B	PM:	3x 0...5 mA/0...20 mA/4...20 mA/ \pm 2 V/ \pm 5 V/ \pm 10 V/ \pm 40 V

PROGRAMMABLE PROJECTION

Selection:	of type of input and measuring range
Measuring range:	adjustable as fixed or with automatic change
Setting:	manual, optional projection on the display may be set in the menu for both limit values of the input signal, e.g. input 0...20 mA > 0...850,0
Projection:	-9999...9999 (-99999...99999)

COMPENSATION

of conduct:	in the menu it is possible to perform compensation for 2-wire connection
of conduct in probe:	internal connection (conduct resistance in measuring head)
of CJC (T/C):	manual or automatic, in the menu it is possible to perform selection of the type of thermocouple and compensation of cold junctions, which is adjustable or automatic (temperature at the brackets)

LINEARIZATION

Linearization:* by linear interpolation in 50 points (solely via OM Link)

DIGITAL FILTERS

Floating average:	from 2...30 measurements
Exponen. average:	from 2...100 measurements
Arithmetic average:	from 2...100 measurements
Rounding:	setting the projection step for display

MATHEMATIC FUCTIONS

Min/max. value:	registration of min./max. value reached during measurement
Tare:	designed to reset display upon non-zero input signal
Peak value:	the display shows only max. or min. value
Mat. operations:	polynome, 1/x, logarithm, exponential, power, root, sin x

* only for types DC, PM, DU

EXTERNAL CONTROL

Lock:	control keys blocking
Hold:	display/instrument blocking
Tare:	tare activation/resetting tare to zero
Resetting MM:	resetting min/max value
Memory:	data storage into instrument memory

2.2 OPERATION

The instrument is set and controlled by five control keys located on the front panel. All programmable settings of the instrument are performed in three adjusting modes:

LIGHT	Simple programming menu - contains solely items necessary for instrument setting and is protected by optional number code
PROFI	Complete programming menu - contains complete instrument menu and is protected by optional number code
USER	User programming menu - may contain arbitrary items selected from the programming menu (LIGHT/PROFI), which determine the right (see or change) - access without password

All programmable parameters are stored in the EEPROM memory (they hold even after the instrument is switched off).

OMLINK Complete instrument operation and setting may be performed via OM Link communication interface, which is a standard equipment of all instruments.

The operation program is freely accessible (www.orbit.merret.eu) and the only requirement is the purchase of OML cable to connect the instrument to PC. It is manufactured in version RS 232 and USB and is compatible with all ORBIT MERRET instruments. Another option for connection is with the aid of data output RS 232 or RS 485 (without the need of the OML cable).

The program OMLINK in „Basic“ version will enable you to connect one instrument with the option of visualization and archiving in PC. The OM Link „Standard“ version has no limitation of the number of instruments connected.

2.3 OPTIONS

Comparators are assigned to monitor one, two, three or four limit values with relay output. The user may select limits regime: LIMIT/DOSING/FROM-TO. The limits have adjustable hysteresis within the full range of the display as well as selectable delay of the switch-on in the range of 0...99,9 s. Reaching the preset limits is signalled by LED and simultaneously by the switch-on of the relevant relay.

Data outputs are for their rate and accuracy suitable for transmission of the measured data for further projection or directly into the control systems. We offer an isolated RS232 and RS485 with the ASCII or DIN MessBus protocol.

Analog outputs will find their place in applications where further evaluating or processing of measured data is required in external devices. We offer universal analog output with the option of selection of the type of output - voltage/current. The value of analog output corresponds with the displayed data and its type and range are selectable in Menu.

Measured data record is an internal time control of data collection. It is suitable where it is necessary to register measured values. Two modes may be used. FAST is designed for fast storage (40 records/s) of all measured values up to 8 000 records. Second mode is RTC, where data record is governed by Real Time with data storage in a selected time segment and cycle. Up to 250 000 values may be stored in the instrument memory. Data transmission into PC via serial interface RS232/485 and OM Link.

3. INSTRUMENT CONNECTION

The instrument supply leads should not be in proximity of the incoming low-potential signals.

Contactors, motors with larger input power should not be in proximity of the instrument.

The leads into the instrument input (measured quantity) should be in sufficient distance from all power leads and appliances. Provided this cannot be secured it is necessary to use shielded leads with connection to ground (bracket E).

The instruments are tested in compliance with standards for use in industrial area, yet we recommend to abide by the above mentioned principles.

MEASURING RANGES

TYPE	INPUT I	INPUT U
DC		0...60/150/300/1 200 mV
PM	0...5/20 mA/4...20 mA	$\pm 2/\pm 5/\pm 10/\pm 40$ V
OHM	0...100 Ω /1 k Ω /10 k Ω /100 k Ω /Autorange	
RTD-PT	Pt 50/100/Pt 500/ Pt 1 000	
RTD-CU	Cu 50/100	
RTD-NI	Ni 1 000/10 000	
T/C	J/K/T/E/B/S/R/N/L	
DU	Linear potentiometer (min. 500 Ω)	

OPTION "A"

TYPE	INPUT I	INPUT U
DC	$\pm 0,1$ A/ $\pm 0,25$ A/ $\pm 0,5$ to GND (C) ± 2 A/ ± 5 A to GND (B)	± 100 V/ ± 250 V/ ± 500 V to GND (C)

OPTION "B"

TYPE	INPUT 2, 3, 4/I	INPUT 2, 3, 4/U
PM	0...5/20 mA/4...20 mA	$\pm 2/\pm 5/\pm 10/\pm 40$ V

Termination of RS 485 communication line

X3 - Termination of communication line RS 485

Full	Significance	Default	Recommendation
1-2	connect L+ to (+) source	terminalconnected	connect at the end of line do not disconnect
3-4	termination of line 120 Ohm	disconnected	
5-6	connect L- to (-) source	terminalconnected	

RS 485 line should have a linear structure - wires (ideally shielded and twisted) should lead from one device to another.

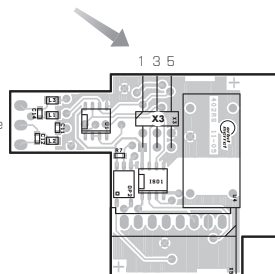

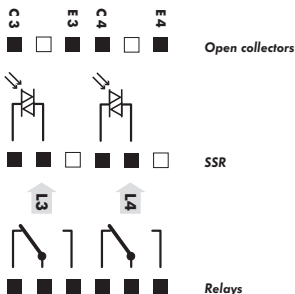

!
Excitation has the minus pole common with the input - the bracket no. 20 - GND and you may set its value by trimmer above the bracket no. 17

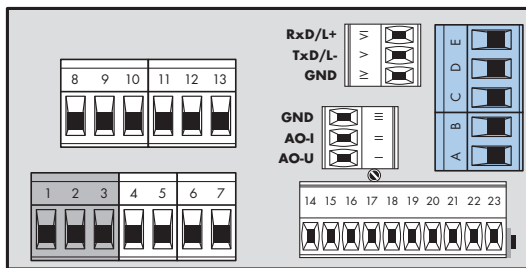

- Option A**
- INPUT - U
 - GND - U/10,5
 - GND - I5
 - INPUT - I

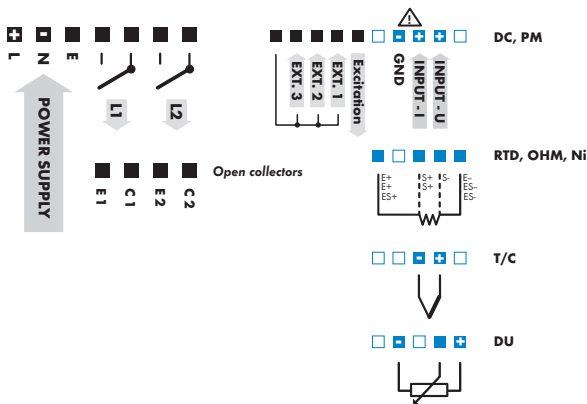

Maximum of 250 mA may be connected to "INPUT - I" (bracket no. 21) , i.e. 10-times range overload.
Mind the correct connection/mistaking of current - voltage input.
Destruction of measuring resistance in current input (15R) may occur.

3. INSTRUMENT CONNECTION

Example connection of a 2-wire sensor with current signal output powered by instrument's excitation

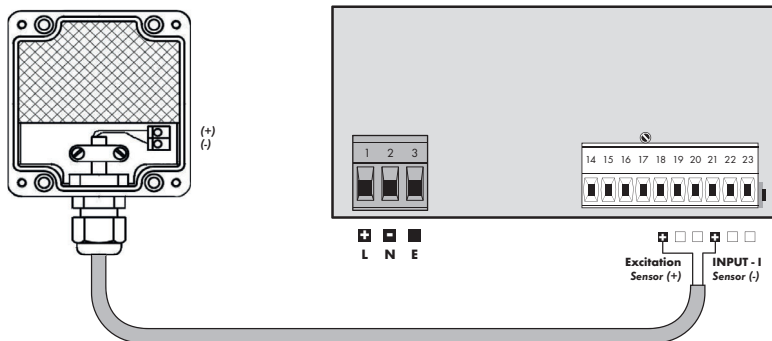

Example connection of a 3-wire sensor with current signal output powered by instrument's excitation

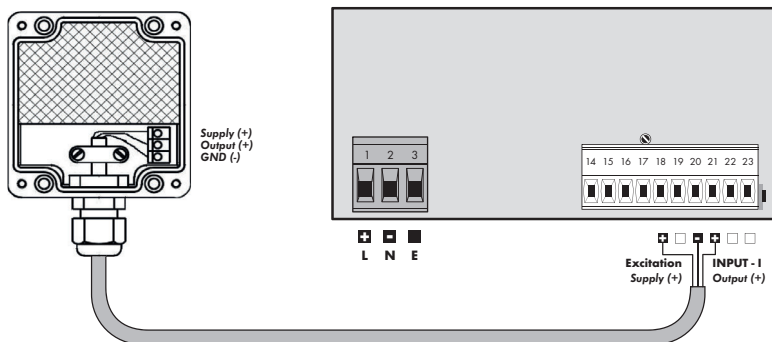

Example connection of 3-wire sensor with voltage signal output powered by instrument's excitation

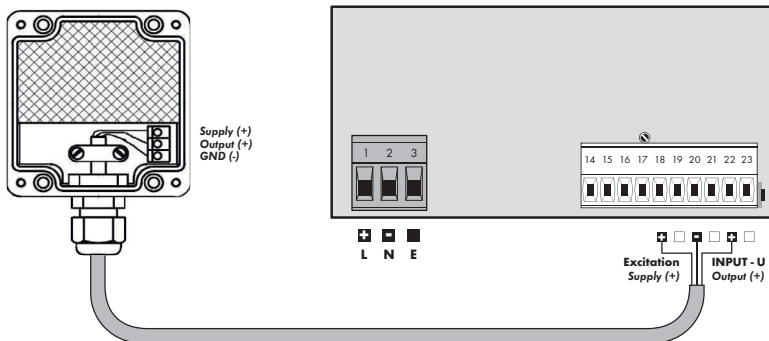

Example connection of resistance measurement using 4 wires

By connecting resistor R* we eliminate error message E. I.Ov. (input overflow) when the measured resistance is disconnected

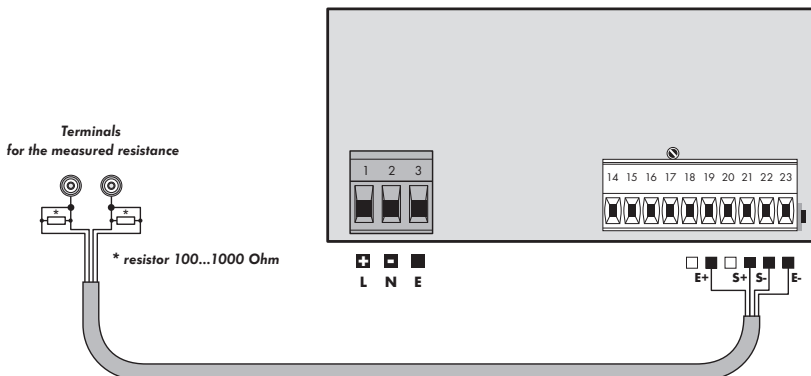



SETTING **PROFI**

For expert users

Complete instrument menu

Access is password protected

Possibility to arrange items of the **USER MENU**

Tree menu structure

SETTING **LIGHT**

For trained users

Only items necessary for instrument setting

Access is password protected

Possibility to arrange items of the **USER MENU**

Linear menu structure

SETTING **USER**

For user operation

Menu items are set by the user (Profi/Light) as per request

Access is not password protected

Optional menu structure either tree (PROFI) or linear (LIGHT)

4.1 SETTING

The instrument is set and controlled by five control keys located on the front panel. All programmable settings of the instrument are performed in three adjusting modes:

- LIGHT** **Simple programming menu**
- contains solely items necessary for instrument setting and is protected by optional number code
- PROFI** **Complete programming menu**
- contains complete instrument menu and is protected by optional number code
- USER** **User programming menu**
- may contain arbitrary items selected from the programming menu (LIGHT/PROFI), which determine the right (see or change)
- acces without password

All programmable parameters are stored in the EEPROM memory (they hold even after the instrument is switched off).

Complete instrument operation and setting may be performed via OM Link communication interface, which is a standard equipment of all instruments.

The operation program is freely accessible (www.orbit.merret.eu) and the only requirement is the purchase of OML cable to connect the instrument to PC. It is manufactured in version RS 232 and USB and is compatible with all ORBIT MERRET instruments.

Another option for connection is with the aid of data output RS 232 or RS 485 (without the need of the OML cable).

Scheme of processing the measured signal

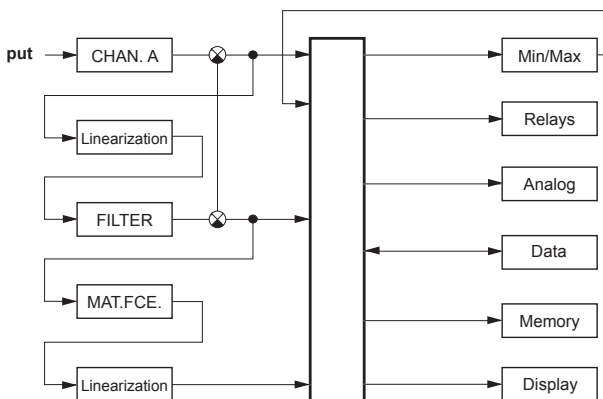

4. INSTRUMENT SETTING

Setting and controlling the instrument is performed by means of 5 control keys located on the front panel. With the aid of these keys it is possible to browse through the operation menu and to select and set required values.

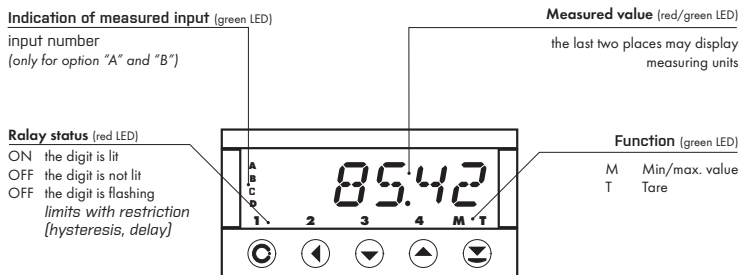

Symbols used in the instructions

DC PM

DU OHM

RTD T/C

Indicates the setting for given type of instrument

DEF

values preset from manufacture

symbol indicates a flashing light (symbol)

inverted triangle indicates the item that can be placed in USER menu

broken line indicates a dynamic item, i.e. it is displayed only in particular selection/version

after pressing the key the set value will not be stored

<

after pressing the key the set value will be stored

30

continues on page 30

Setting the decimal point and the minus sign

DECIMAL POINT

Its selection in the menu, upon modification of the number to be adjusted it is performed by the control key with transition beyond the highest decade, when the decimal point starts flashing. Positioning is performed by .

THE MINUS SIGN

Setting the minus sign is performed by the key on higher decade. When editing the item subtraction must be made from the current number (e.g.: 013 > , on class 100 > -87)

Control keys functions

KEY	MEASUREMENT	MENU	SETTING NUMBERS/SELECTION
	access into USER menu	exit menu	quit editing
	programmable key function	back to previous level	move to higher decade
	programmable key function	move to previous item	move down
	programmable key function	move to next item	move up
	programmable key function	confirm selection	confirm setting/selection
			numeric value is set to zero
	access into LIGHT/PROFI menu		
	direct access into PROFI menu		
		configuration of an item for "USER" menu	
		determine the sequence of items in "USER - LIGHT" menu	

Setting items into „USER“ menu

- in LIGHT or PROFI menu
- no items permitted in USER menu from manufacture
- on items marked by inverted triangle

USER

legend is flashing - current setting is displayed



	item will not be displayed in USER menu
	item will be displayed in USER menu with the option of setting
	item will be solely displayed in USER menu

SETTING **LIGHT**

For trained users

Only items necessary for instrument setting

Access is password protected

Possibility to arrange items of the **USER MENU**

Linear menu structure

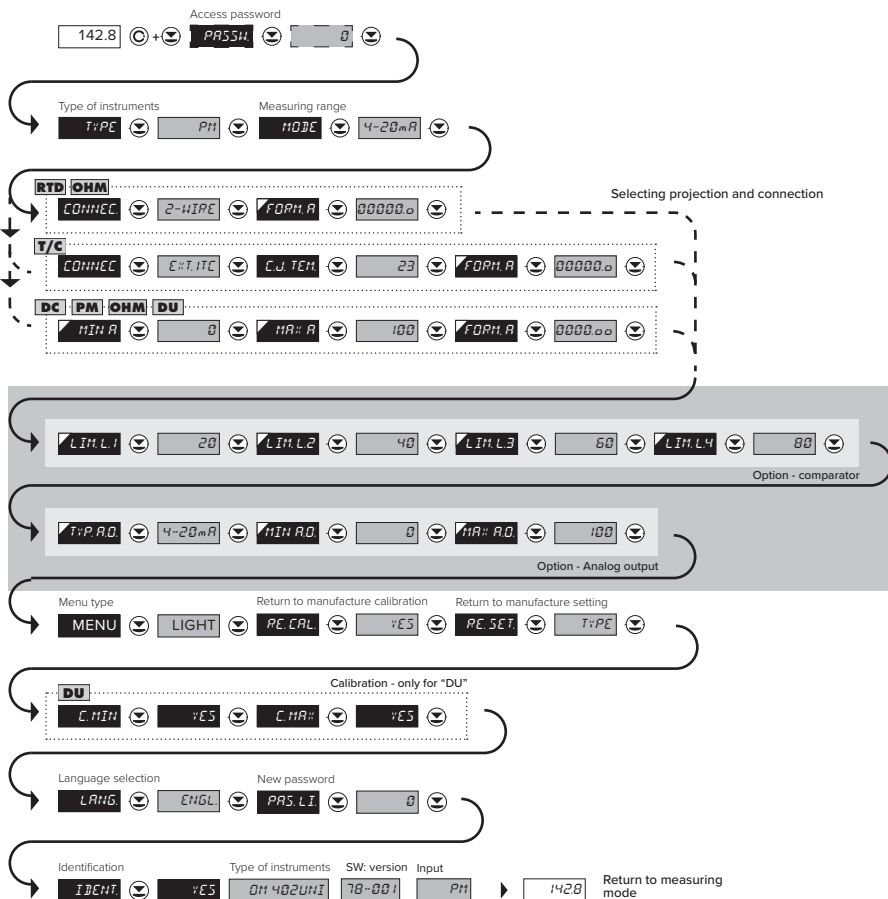

Preset from manufacture

Password	"0"
Menu	LIGHT
USER menu	off
Setting the items	DEF

! Upon delay exceeding 60 s the programming mode is automatically discontinued and the instrument itself restores the measuring mode

5. SETTING LIGHT

1428



PASSH



0

Entering access password for access into the menu



PASSH Access into instrument menu

PAS = 0

- access into menu is unrestricted, after releasing keys you automatically move to first item of the menu

PAS > 0

- access into menu is protected by number code

Set "Password" = 42 Example

T+PE



T+PE Selection of the type of instrument

- primary selection of the type of instrument
- performs default setting **DEF** of values from manufacture, incl. calibration
- **DEF** = „PM“

Menu	Type of instrument
DC	DC voltmeter
PM	Process monitor
OHM	Ohmmeter
RTD-Pt	Thermometer for sensors Pt
RTD-Ni	Thermometer for sensors Ni
TC	Thermometer for thermocouples
DU	Display for lin. potentiometer
RTD-Cu	Thermometer for sensors Cu

Type "PM" Example

Type „DC“	18
Type „PM“	20
Type „OHM“	22
Type „RTD-Pt“	24
Type „RTD-Ni“	26
Type „TC“	28
Type „DU“	30
Type „RTD-Cu“	32



SETTING LIGHT 5.

5. SETTING LIGHT

MEASURING MODE > DC



MODE Selection of the instrument measuring range

DEF = 60 mV

DEF = 500 V*

* only for option "A"

	Menu	Measuring range
MODE	60 mV	±60 mV
	150 mV	±150 mV
	300 mV	±300 mV
	1200mV	±1.2 V
MODE-A	100 V	±100 V
	250 V	±250 V
	500 V	±500 V
	0.10 A	±0,1 A
	0.25 A	±0,25 A
	0.50 A	±0,5 A
	1.00 A	±1 A
	5.00 A	±5 A

Range ±150 mV Example

60 mV 150 mV MIN A



MIN A Setting display projection for minimum value of input signal

- range of the setting: -99999...999999
- position of the DP does not affect display projection

- the DP is automatically shifted after the value is confirmed

DEF = 0

Projection for 0 mV > MIN A = 0 Example

MIN A

5. SETTING LIGHT

MEASURING MODE > PM

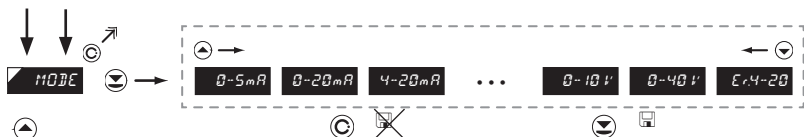

MODE Selection of the instrument measuring range

DEF = 4 - 20 mA

Menu	Measuring range
0-5mA	0...5 mA
0-20mA	0...20 mA
4-20mA	4...20 mA
0-2 V	±2 V
0-5 V	±5 V
0-10 V	±10 V
0-40 V	±40 V
Er4-20	4...20 mA, with error statement of „underflow“ upon signal smaller than 3.36 mA

Range 0...20 mA Example

4-20mA 0-20 mA MIN R



MIN R Setting display projection for minimum value of input signal

- range of the setting: -99999...999999
- position of the DP does not affect display projection

- the DP is automatically shifted after the value is confirmed

DEF = 0

Projection for 0 mA > MIN A = 25 Example



11A: A Setting display projection for maximum value of input signal

- the DP is automatically shifted after the value is confirmed
- range of the setting: -99999...999999
- position of the DP does not affect display projection

DEF = 100

Projection for 20 mA > MAX A = 2500 Example

100	100	100	200	300	400
500	0500	1500	2500	FORM.A	

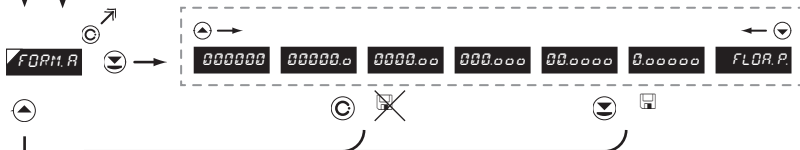

FORM.A Setting projection of the decimal point

- positioning of the DP is set here in the measuring mode

DEF = 0000.00

Projection of DP on display > 00000.0 Example

0000.00	00000.00	MENU
---------	----------	------

*subsequent item on the menu depends on instrument equipment

5. SETTING LIGHT

MEASURING MODE > OHM

The diagram illustrates the sequence of menu selections for setting the instrument to Ohm mode. It begins with the **MODE** menu, where the measuring range is set to **100 R**. This leads to a detailed view of the **MODE** menu, showing the selection of instrument measuring range with a definition of **DEF = 100 Ω**. A table lists the available menu options and their corresponding measuring ranges. Next, the **CONNECT** menu is accessed to select the type of sensor connection, with **DEF = 2-WIRE**. A table shows the connection options. Finally, the **MIN A** menu is used to set the minimum input signal to **0**. A detailed view of the **MIN A** menu explains the setting's range and projection behavior, with **DEF = 0**.

MODE Selection of instrument measuring range

DEF = 100 Ω

Menu	Measuring range
100 R	0...100 Ω
1 k	0...1 kΩ
10 k	0...10 kΩ
100 k	0...100 kΩ
AUTO	Autorange

Range 0...10 kΩ Example

CONNECT Selection of the type of sensor connection

DEF = 2-WIRE

Menu	Connection
2-WIRE	2-wire
3-WIRE	3-wire
4-WIRE	4-wire

Type of connection - 3 wire > CONNECT = 3-WIRE Example

MIN A Setting for minimum input signal

Setting for minimum input signal

MIN A Setting display projection for minimum value of input signal

- range of the setting: -99999...999999
- position of the DP does not affect display projection

- the DP is automatically shifted after the value is confirmed

DEF = 0

Projection for 0 Ohm > MIN A = 0 Example



MR: R Setting display projection for maximum value of input signal

- the DP is automatically shifted after the value is confirmed
- range of the setting: -99999...999999
- position of the DP does not affect display projection

DEF = 100

Projection for 10 kOhm > MAX A = 10000 Example

100	100	100	000	0000	00000
0000	FORM R				

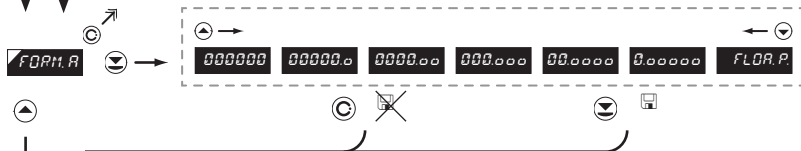

FORM R Setting projection of the decimal point

- positioning of the DP is set here in the measuring mode

DEF = 0000.00

Projection of DP on display > 00000.0 Example

0000.00	00000.0	MENU
---------	---------	------

*subsequent item on the menu depends on instrument equipment

5. SETTING LIGHT

MEASURING MODE > RTD - Pt



MODE Selection of instrument measuring range

DEF = Pt 100

MODE	Menu	Measuring range
	EU-100	Pt 100 (3 850 ppm ^o C)
	EU-500	Pt 500 (3 850 ppm ^o C)
	EU-1k0	Pt 1000 (3 850 ppm ^o C)
	US-100	Pt 100 (3 920 ppm ^o C)
	RU-50	Pt 50 (3 910 ppm ^o C)
	RU-100	Pt 100 (3 910 ppm ^o C)

Range - Pt 1 000 > MODE = EU-1k0 Example

EU-100 ◀ EU-500 ▶ **EU-1k0** ▼ **CONNECT**

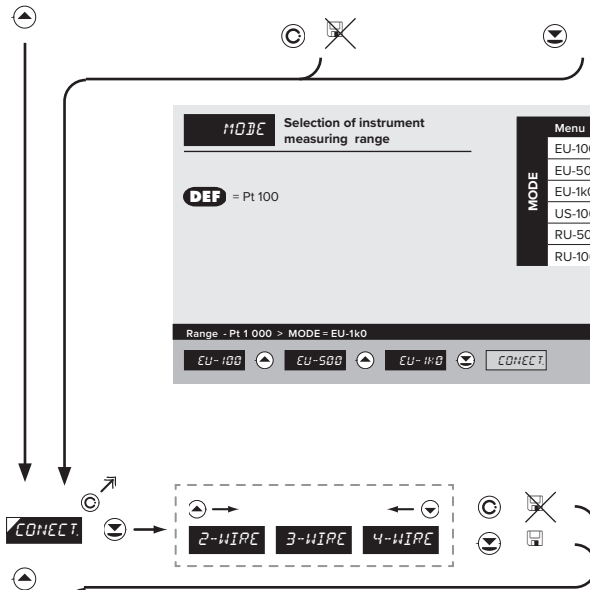

CONNECT Selection of the type of sensor connection

DEF = 2-WIRE

CONNECT	Menu	Connection
	2-WIRE	2-wire
	3-WIRE	3-wire
	4-WIRE	4-wire

Type of connection - 3 wire > CONNECT = 3-WIRE Example

2-WIRE ▶ **3-WIRE** ▼ **FORM A**

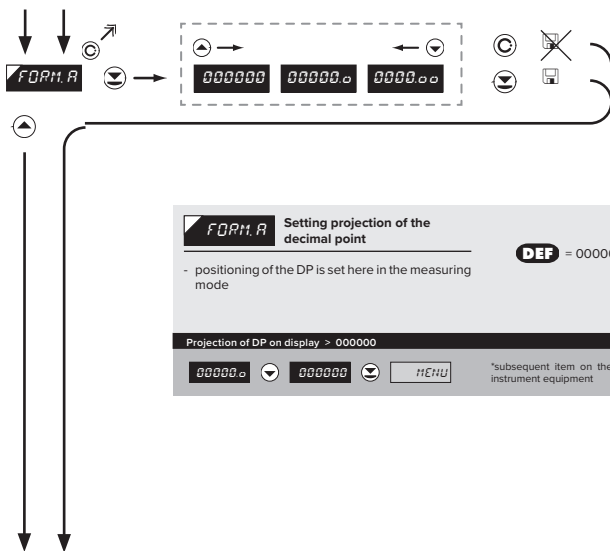

FORM.A Setting projection of the decimal point

DEF = 00000.0

- positioning of the DP is set here in the measuring mode

Projection of DP on display > 000000 Example

00000.0	▼	000000	▼	[MENU]	*subsequent item on the menu depends on instrument equipment
---------	---	--------	---	--------	--------------------------------------------------------------

5. SETTING LIGHT

MEASURING MODE > RTD - Ni

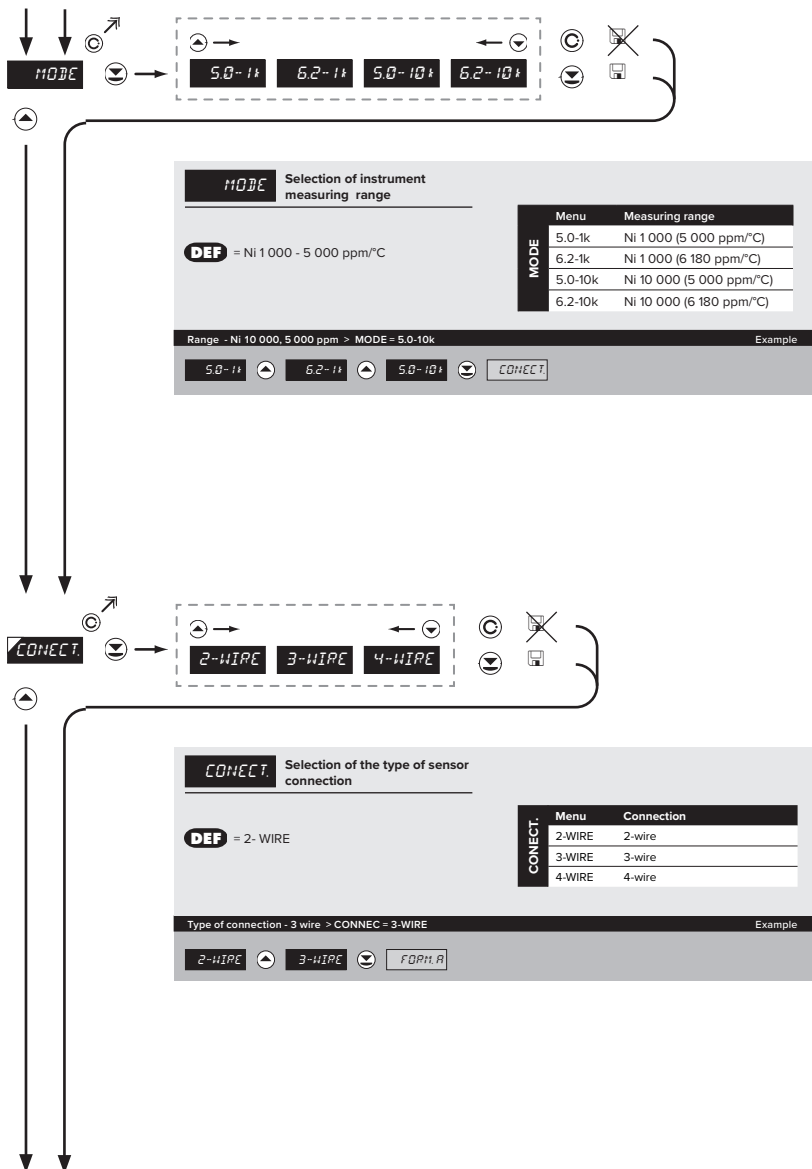

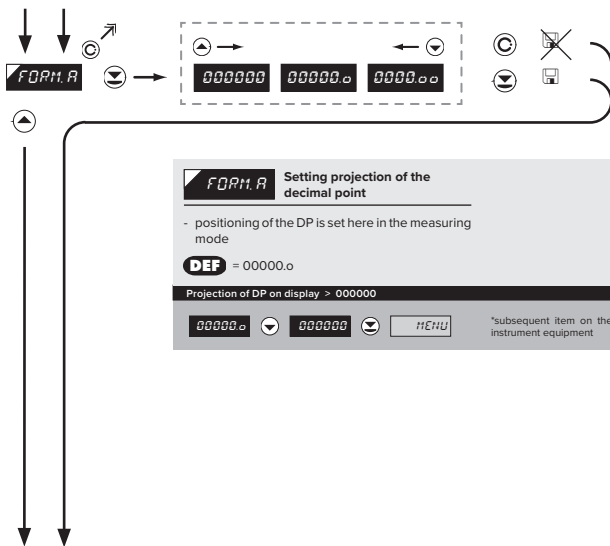

6. SETTING PROFI

MEASURING MODE > T/C



MODE Selection of the type of thermocouple

DEF = Type "J"

Menu	Type of thermocouple
T/C B	B
T/C E	E
T/C J	J
T/C K	K
T/C N	N
T/C R	R
T/C S	S
T/C T	T
T/C L	L

Type of thermocouple "K" Example

J K CONNECT



CONNECT Selection of the type of sensor connection

DEF = EXT. 1TC

Menu	Connection	Ref. T/C
INT.1TC	measuring C.J. at instrument brackets	✗
INT.2TC	measuring C. J. at instrument brackets with anti-series connected ref. TC	✓
EXT.1TC	the entire measuring set is working under invaried and constant temperature	✗
EXT.2TC	when using compensation box	✓

Type of connection -> CONNECT = EXT. 2TC Example

EXT.1TC EXT.2TC C.J. TEM

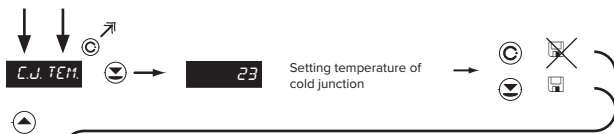

Setting temperature of cold junction

C.J. TEM. Setting temperature of cold junction

- range 0...99°C with compensation box

DEF = 23

Setting temperature of cold junction > C.J. TEM. = 35

Example

23 24 25 26

FORM.A



FORM.A Setting projection of the decimal point

- positioning of the DP is set here in the measuring mode

DEF = 00000.0

Projection of DP on display > 000000

Example

00000.0 000000 MENU

*subsequent item on the menu depends on instrument equipment

!
For thermocouple type "B" the items CONECT. and C.J. TEM. are not available

!
Method and procedure of setting the cold junctions is described in separate chapter on page 80

5. SETTING LIGHT

MEASURING MODE > DU

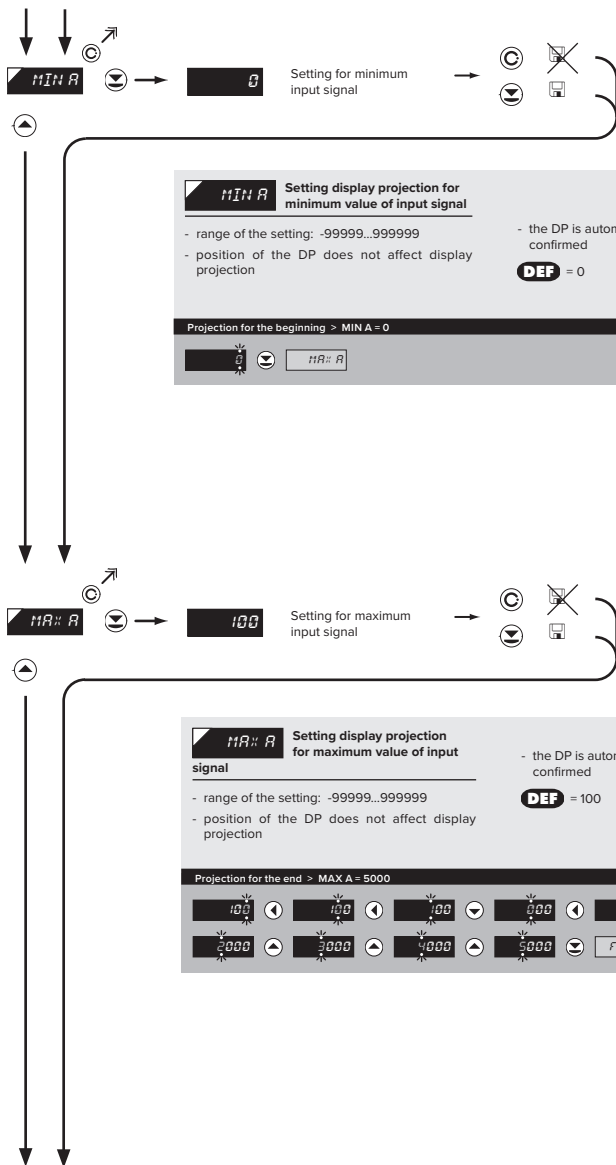

MIN A Setting display projection for minimum value of input signal

- range of the setting: -99999...999999
- position of the DP does not affect display projection

- the DP is automatically shifted after the value is confirmed
DEF = 0

Projection for the beginning > MIN A = 0 Example

MAX A Setting display projection for maximum value of input signal

- range of the setting: -99999...999999
- position of the DP does not affect display projection

- the DP is automatically shifted after the value is confirmed
DEF = 100

Projection for the end > MAX A = 5000 Example

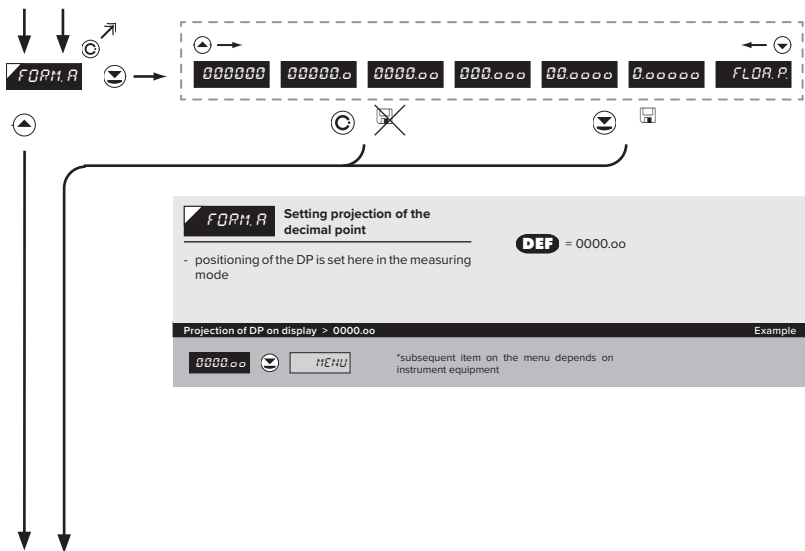

34

Calibration of the beginning and the end of range of linear potentiometer is on page 39

5. SETTING LIGHT

MEASURING MODE > RTD - Cu

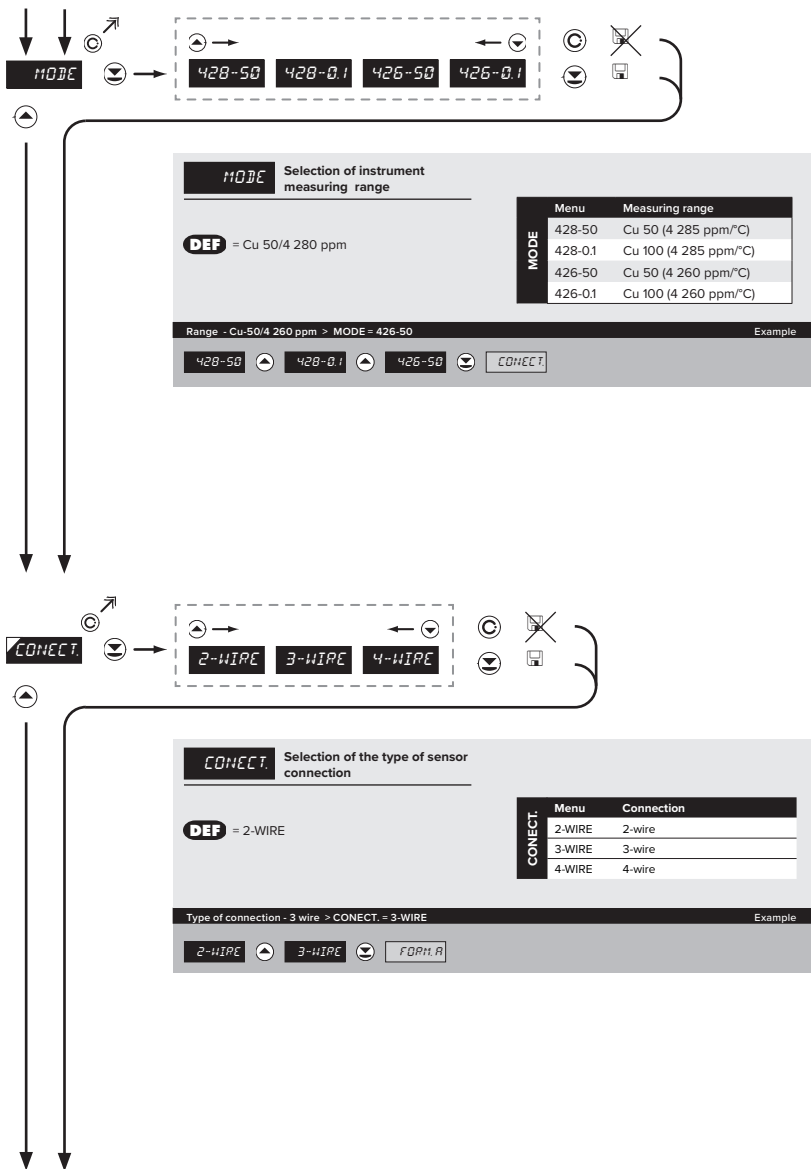

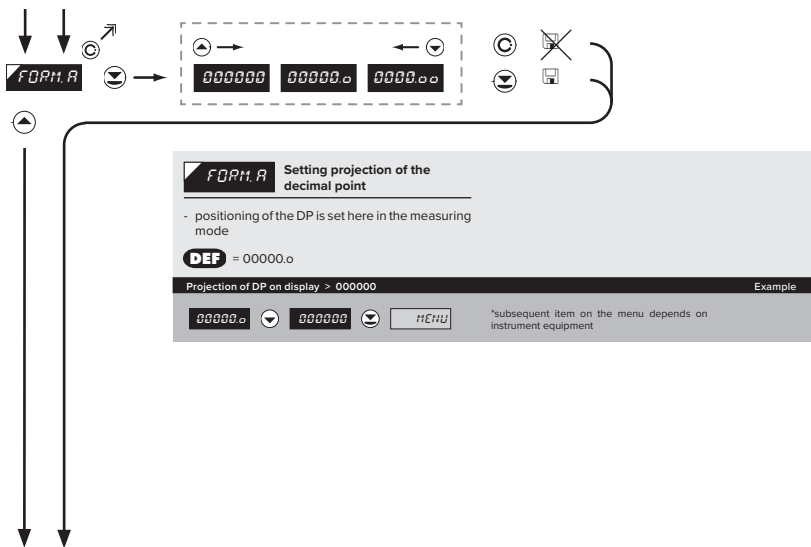

5. SETTING LIGHT

DISPLAYED ONLY WITH OPTIONS > COMPARATORS

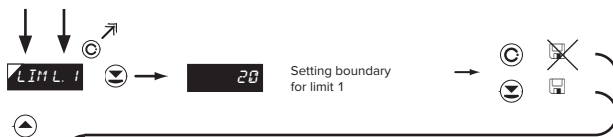

LIM L1 Setting boundary for limit 1

- range of the setting: -99999...999999
- contingent modification of hysteresis or delay may be performed in "PROFI" menu

DEF = 20
DEF „Hysteresis“=0 „Delay“=0

Setting limit 1 > L 1 = 32 Example

20

20

20

20

20

MENU

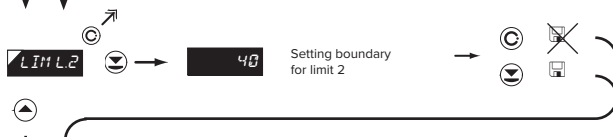

LIM L2 Setting boundary for limit 2

- range of the setting: -99999...999999
- contingent modification of hysteresis or delay may be performed in "PROFI" menu

DEF = 40
DEF „Hysteresis“=0 „Delay“=0

Setting limit 2 > L 2 = 53.1 Example

40

41

41

31

31

31

53.1

53.1

53.1

MENU

* subsequent item on the menu depends on instrument equipment

! Items for "Limits" and "Analog output" are accessible only if incorporated in the instrument.

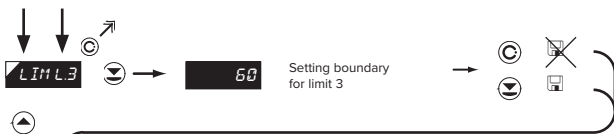

LIM L3 Setting boundary for limit 3

- range of the setting: -99999...999999
- contingent modification of hysteresis or delay may be performed in "PROFI" menu

DEF = 60
DEF „Hysteresis“=0, „Delay“=0

Setting limit 3 > L 3 = 85 Example

60	61	62	63	64	65
65	75	85	HELU	* subsequent item on the menu depends on instrument equipment	



LIM L4 Setting boundary for limit 4

- range of the setting: -99999...999999
- contingent modification of hysteresis or delay may be performed in "PROFI" menu

DEF = 80
DEF „Hysteresis“=0, „Delay“=0

Setting limit 4 > L 4 = 103 Example

80	81	82	83	84	85
83	903	103	HELU	* subsequent item on the menu depends on instrument equipment	

5. SETTING LIGHT

DISPLAYED ONLY WITH OPTIONS > ANALOG OUTPUT

TYP. A.O. Setting the type of analog output

Menu	Range	Description
0..20mA	0...20 mA	
Er.4- T	4...20 mA	with error message indication and broken loop indication (<3.6 mA)
4..20T	4...20 mA	with broken loop indication (<3.6 mA)
Er.4..20	4...20 mA	with indication of error statement (<3.6 mA)
4..20mA	4...20 mA	
0..5mA	0...5 mA	
0..2 V	0...2 V	
0..5 V	0...5 V	
0..10 V	0...10 V	
+10 V	±10 V	

DEF = 4...20 mA

Type of analog output - 0...10 V > TYP. A.O. = 0-10 V

Example: 4-20mA, 0-5mA, 0-2V, 0-5V, 0-10V, MIN. A.O.

MIN. A.O. Assigning the display value to the beginning of the AO range

- range of the setting: -99999...999999

DEF = 0

Display value for the beginning of the AO range > MIN A.O. = 0

Example: 0, MIN. A.O.

Assigning the display value to the beginning of the AO range

Items for "Limits" and "Analog output" are accessible only if incorporated in the instrument.

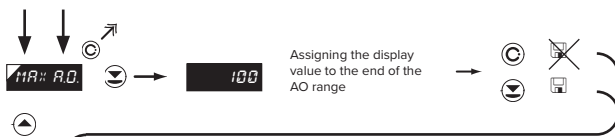

11A: A.O. Assigning the display value to the end of the AO range

- range of the setting: -99999...999999 **DEF** = 100

Display value for the end of the AO range > MAX.A.O. = 120 Example

100 100 110 120 MENU

DISPLAYED ONLY WITH OPTIONS > ANALOG OUTPUT

5. SETTING LIGHT

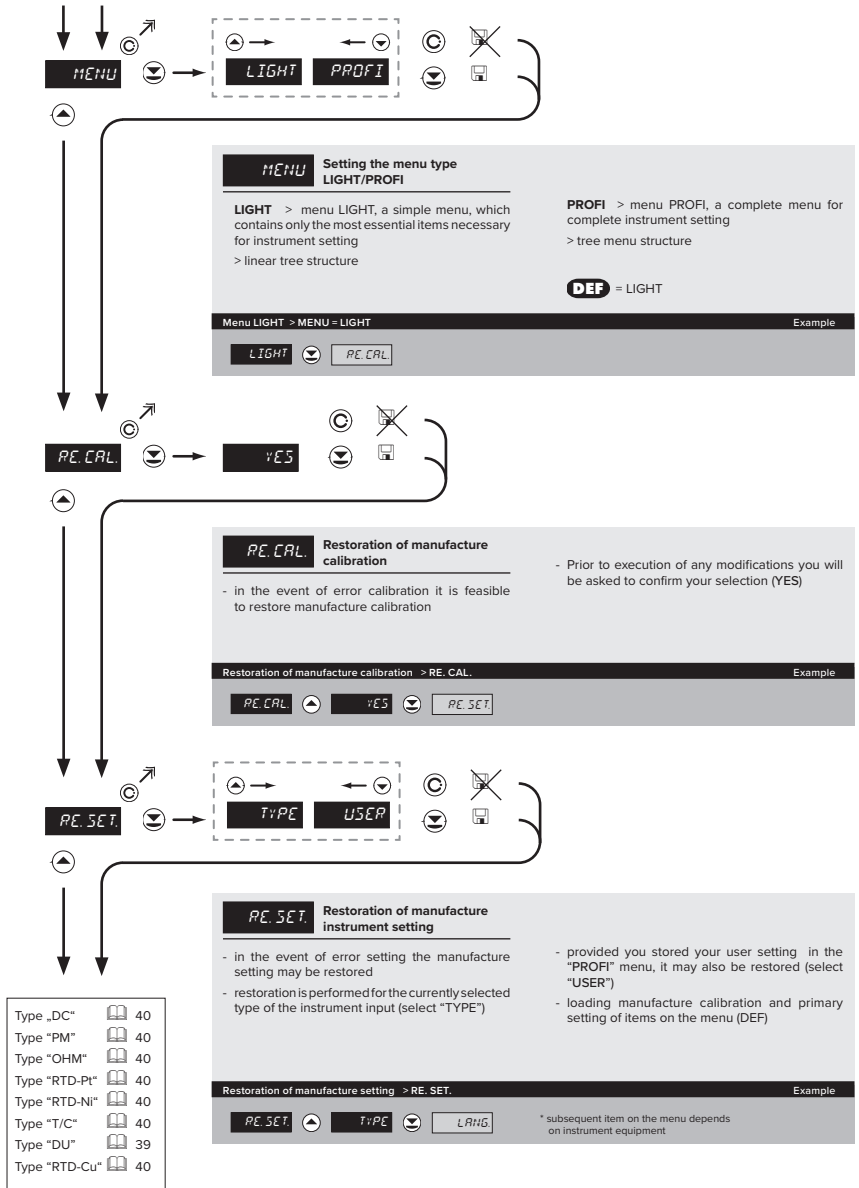

Type „DC“	40
Type "PM"	40
Type "OHM"	40
Type "RTD-Pt"	40
Type "RTD-Ni"	40
Type "T/C"	40
Type "DU"	39
Type "RTD-Cu"	40

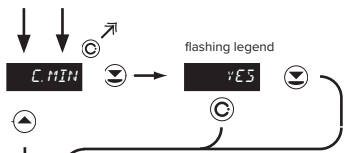

C.MIN Calibration of input range - the potentiometer traveller in initial position

Only for type "DU"

- prior confirming the flashing "YES" sign the potentiometer traveller has to be in given idle position

Calibration of the beginning of the range > C. MIN

Example

YES C.MAX

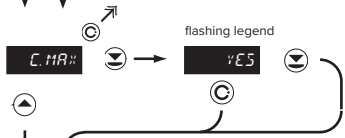

C.MAX Calibration of input range - the potentiometer traveller in end position

Only for type "DU"

- prior confirming the flashing "YES" sign the potentiometer traveller has to be in given idle position

Calibration of the end of the range > C. MAX

Example

YES L.ANG

5. SETTING LIGHT

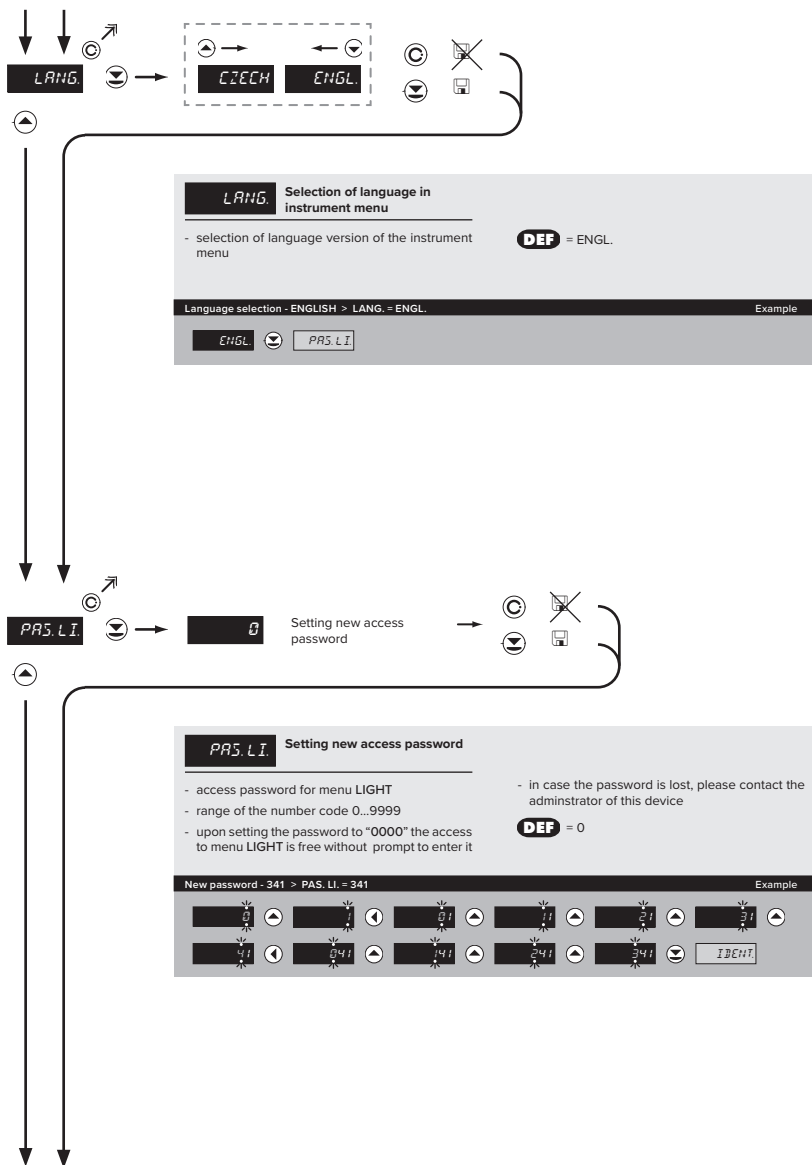

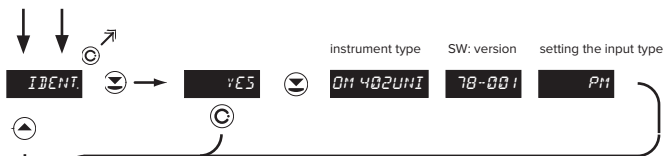

IDENT. Instrument SW version

- the display shows the type of instrument indication, SW number, SW version and current input setting (Mode)
- if SW version contains a letter in first position, then it is a customer SW

- after the identification is completed the menu is automatically exited and the instrument restores the measuring mode

1428

Return to measuring mode

SETTING **PROFI**

For expert users

Complete instrument menu

Access is password protected

Possibility to arrange items of the **USER MENU**

Tree menu structure

6.0 SETTING “PROFI”

PROFI

Complete programming menu

- contains complete instrument menu and is protected by optional number code
- designed for expert users
- preset from manufacture is menu **LIGHT**

Switching over to “PROFI” menu



- access to **PROFI** menu
- authorization for access to **PROFI** menu does not depend on setting under item **SERVIC. > MENU**
- password protected access (unless set as follows under the item **SERVIC. > N. PASS. > PROFI =0**)



- access to menu selected under item **SERVIC. > MENU > LIGHT/PROFI**
- password protected access (unless set as follows under the item **SERVIC. > N. PASS. > LIGHT =0**)
- for access to **LIGHT** menu passwords for **LIGHT** and **PROFI** menu may be used



6. SETTING PROFI

Programming sch

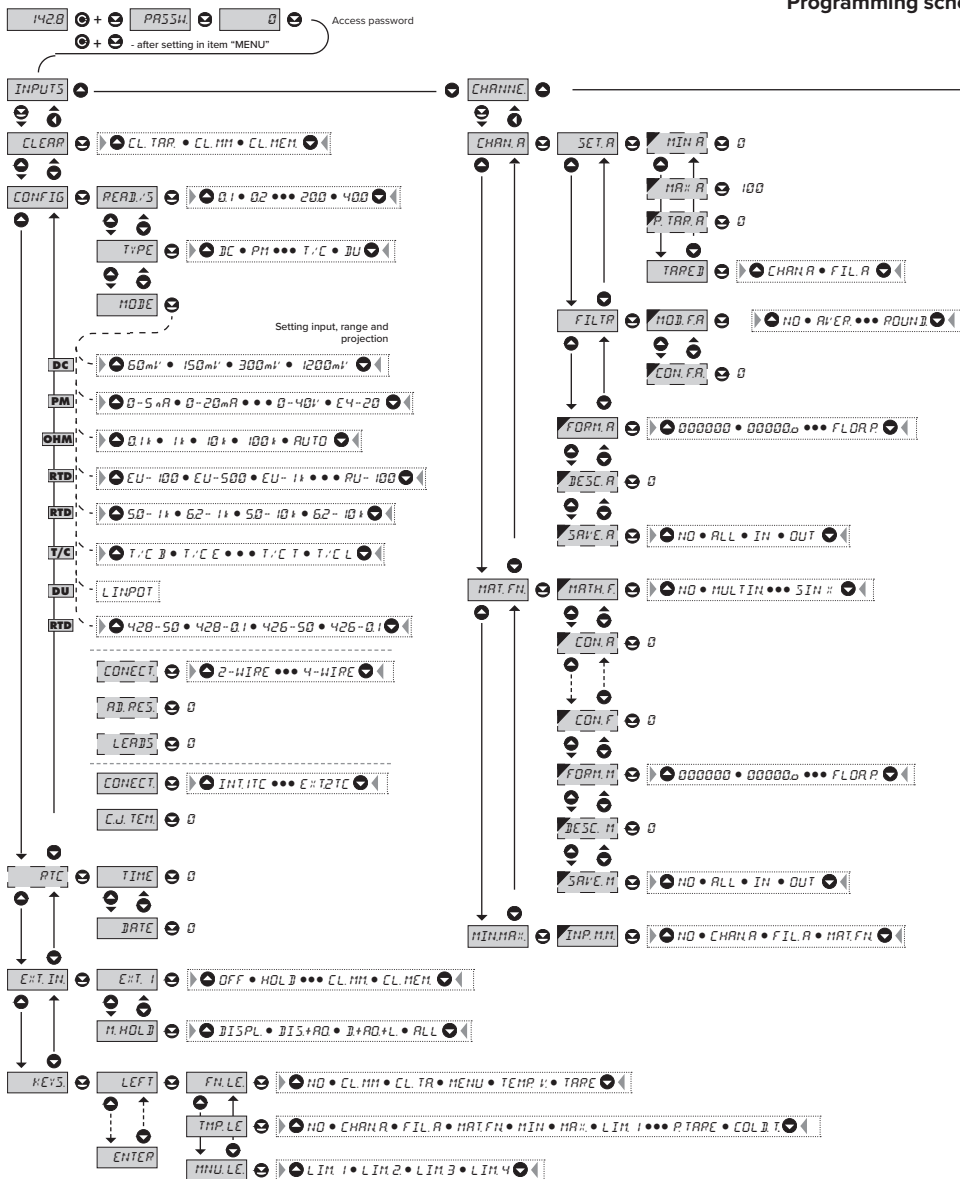

NAME PROFI MENU

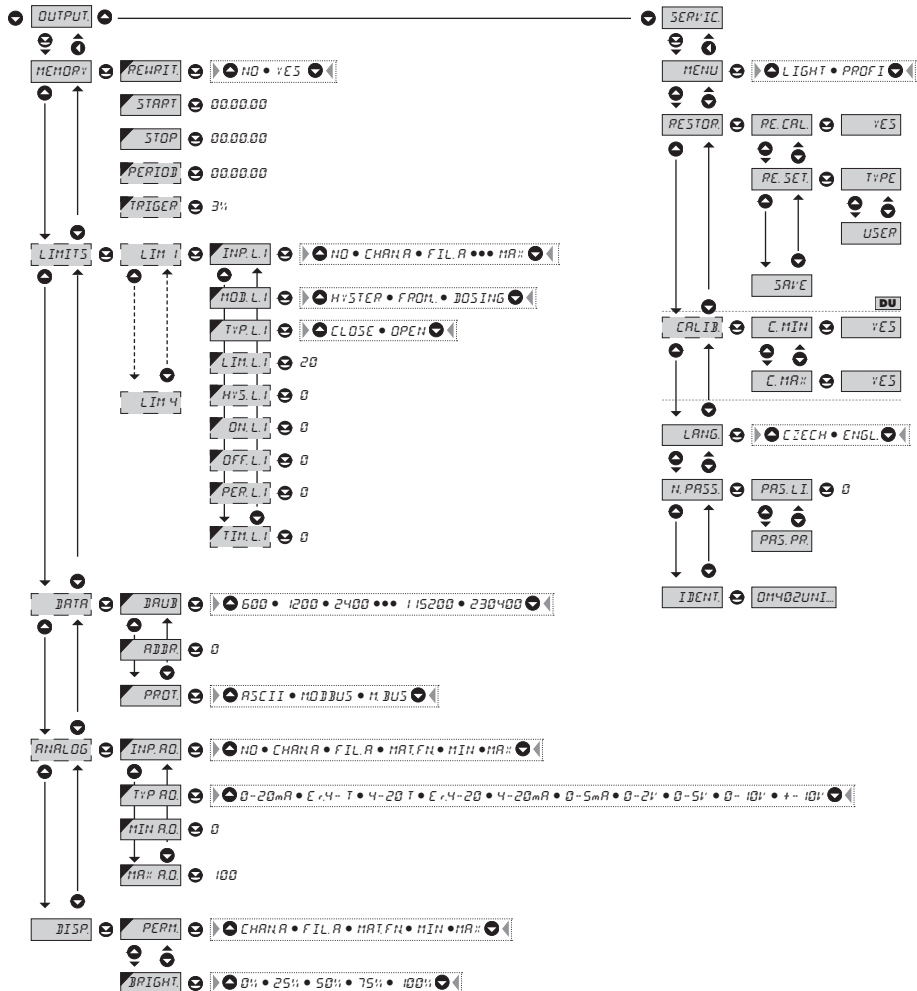

! Upon delay exceeding 60 s the programming mode is automatically discontinued and the instrument itself restores the measuring mode

6. SETTING PROFI

6.1 SETTING "PROFI" - INPUT

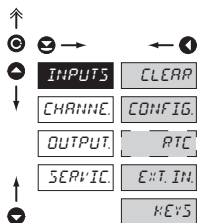

The primary instrument parameters are set in this menu

CLEAR	Resetting internal values
CONFIG.	Selection of measuring range and parameters
RTC	Setting date and time for option with RTC
EXT. IN.	Setting external inputs functions
KEYS	Assigning further functions to keys on the instrument

6.1.1 RESETTING INTERNAL VALUES

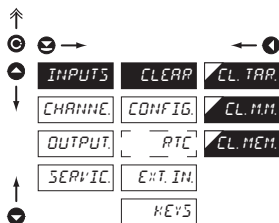

CLEAR	Resetting internal values
CL. TAR.	Tare resetting
CL. MM.	Resetting min/max value
- resetting memory for the storage of minimum and maximum value achieved during measurement	
CL. MEM.	Resetting the instrument memory
- resetting memory with data measured in the "FAST" or "RTC" modes	
- not in standard equipment	

6.1.2a SELECTION OF MEASURING RATE

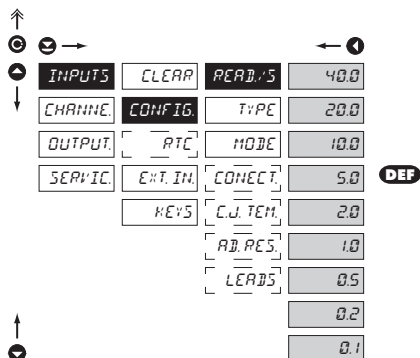
**PERIODS** Selection of measuring rate

40.0	40,0 measurements/s
20.0	20,0 measurements/s
10.0	10,0 measurements/s
5.0	5,0 measurements/s
2.0	2,0 measurements/s
1.0	1,0 measurement/s
0.5	0,5 measurements/s
0.2	0,2 measurements/s
0.1	0,1 measurements/s

6.1.2b SELECTION OF „INSTRUMENT“ TYPE

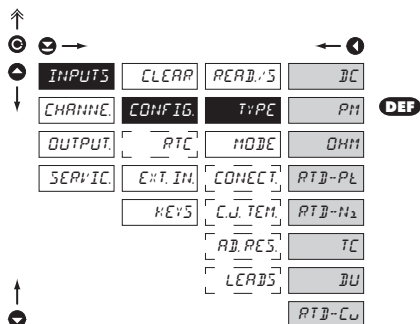
**TYPE** Selection of „instrument“ type

- selection of particular type of "instrument" is bound to relevant dynamic items

DC	DC voltmeter
PM	Process monitor
OHM	Ohmmeter
RTD-Pt	Thermometer for Pt xxx
RTD-Ni	Thermometer for Ni xxxx
TC	Thermometer pro thermocouples
DU	Display for linear potentiometers
RTD-Cu	Thermometer for Cu xxx

6. SETTING PROFI

6.1.2c SELECTION OF MEASURING RANGE

↑

⊖ →

⊕

↓

INPUTS	CLEAR	READ/5	DC 60mV	OHM 100 R	
CHANNEL	CONFIG	TYPE	150mV	1 k	DEF
OUTPUT	PTC	MODE	300mV	10 k	
SERVIC	ENT. IN	CONNECT	1200mV	100 k	
	KEYS	C.J. TEN		AUTO	
		AB. RES			
		LEADS			

	DC - A	PM			
	100 V	0-5 mA			
	250 V	0-20 mA			
DEF	500 V	4-20 mA	DEF		
	0.10 A	0-2 V			
	0.25 A	0-5 V			
	0.50 A	0-10 V			
	1.00 A	0-40 V			
	5.00 A	Er.4-20			

	RTD-Pt	RTD-Cu			
DEF	EU-100	428-50	DEF		
	EU-500	428-0.1			
	EU-1k0	426-50			
	US-100	426-0.1			
	RU-50				
	RU-100				

	T/C				
	T/C B				
	T/C E				
DEF	T/C J	DEF			
	T/C K				
	T/C N				
	T/C P				
	T/C S				
	T/C T				

	DU				
DEF	LTH.POT.	T/C L			

↑

⊖

Switching in the mode
AUTO - "OHM"

0.1 kΩ > 1 kΩ 0.101 k
 1 kΩ > 10 kΩ 1.010 k
 10 kΩ > 100 kΩ 10.10 k
 100 Ω > 10 kΩ 9.900 k
 10 kΩ > 1 kΩ 0.990 k
 1 kΩ > 0.1 kΩ 0.099 k

When selecting the "AUTO"
range, the items "MIN", "MAX",
"P. TAR. A" will not be displayed
in the "CHAN. A" setting

MODE Selection of instrument measuring range

	Menu	Measuring range
DC	60 mV	±60 mV
	150 mV	±150 mV
	300 mV	±300 mV
	1200mV	±1.2 V
DC - A	100 V	±100 V
	250 V	±250 V
	500 V	±500 V
	0.10 A	±0.1 A
	0.25 A	±0.25 A
	0.50 A	±0.5 A
	1.00 A	±1 A
	5.00 A	±5 A
PM	Menu	Measuring range
	0-5mA	0...5 mA
	0-20mA	0...20 mA
	4-20mA	4...20 mA
	0-2 V	±2 V
	0-5 V	±5 V
	0-10 V	±10 V
0-40 V	±40 V	
Er.4-20	4...20 mA, with error statement of „underfl ow“ upon signal smaller than 3,36 mA	
OHM	Menu	Measuring range
	100 R	0...100 Ω
	1 k	0...1 kΩ
	10 k	0...10 kΩ
	100 k	0...100 kΩ
	AUTO	Autorange
RTD-PT	Menu	Measuring range
	EU-100	Pt 100 (3 850 ppm/°C)
	EU-500	Pt 500 (3 850 ppm/°C)
	EU-1k0	Pt 1000 (3 850 ppm/°C)
	US-100	Pt 100 (3 920 ppm/°C)
	RU-50	Pt 50 (3 910 ppm/°C)
	RU-100	Pt 100 (3 910 ppm/°C)
RTD-NI	Menu	Measuring range
	5.0-1k	Ni 1 000 (5 000 ppm/°C)
	6.2-1k	Ni 1 000 (6 180 ppm/°C)
	5.0-10k	Ni 10 000 (5 000 ppm/°C)
	6.2-10k	Ni 10 000 (6 180 ppm/°C)
RTD-CU	Menu	Measuring range
	428-50	Cu 50 (4 280 ppm/°C)
	428-0.1	Cu 1 00 (4 280 ppm/°C)
	426-50	Cu 50 (4 260 ppm/°C)
	426-0.1	Cu 100 (4 260 ppm/°C)
T/C	Menu	Type of thermocouple
	T/C B	B
	T/C E	E
	T/C J	J
	T/C K	K
	T/C N	N
	T/C R	R
	T/C S	S
T/C T	T	
	T/C L	L

48 | INSTRUCTIONS FOR USE OM 402UNI

6.1.2d

SELECTION OF TYPE OF SENSOR CONNECTION

RTD OHM T/C

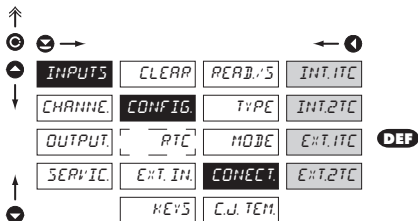
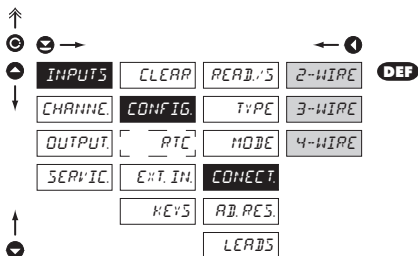
**CONNECT.** Selection of type of sensor connection**RTD OHM**

2-WIRE 2-wire connection

3-WIRE 3-wire connection

4-WIRE 4-wire connection

T/C

INT. ITC Measurement without reference thermocouple

- measuring cold junction at instrument brackets

INT. 2TC Measurement with reference thermocouple

- measuring cold junction at instrument brackets with anti-series connected reference thermocouple

EXT. ITC Measurement without reference thermocouple

- the entire measuring set is working under invaried and constant temperature

EXT. 2TC Measurement with reference thermocouple

- when using compensation box

! Method and procedure of setting the cold junctions is described in separate chapter on page 80

! For thermocouple type "B" the items CONECT. and C.J. TEM. are not available

6. SETTING PROFI

6.1.2e SETTING TEMPERATURE OF COLD JUNCTION

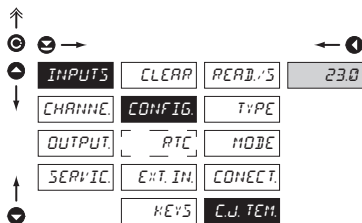
T/C

C.J. TEM. Setting temperature of cold junction

- range 0...99°C with compensation box
- **DEF** = 23°C

6.1.2f ZERO OFFSET OF THE MEASUREMENT RANGE

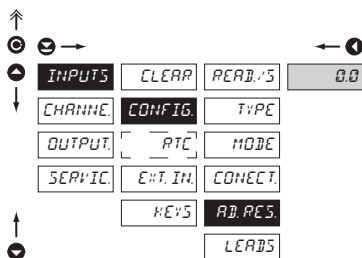
RTD OHM

AD.PRES. Offset of the beginning of the measuring range

- in cases when it is necessary to offset the beginning of the range by certain value, e.g. while using sensor in measuring head
- entered directly in Ohm (0...9999)
- **DEF** = 0

6.1.2g COMPENSATION OF 2-WIRE CONDUCT

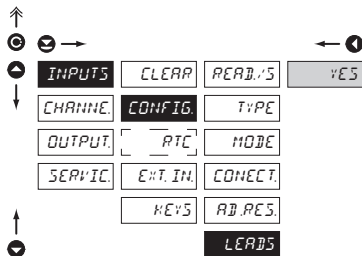
RTD OHM

LEADS Compensation of 2-wire conduct

- for measurement accuracy it is necessary to perform compensation of conduct always in case of 2-wire connection
- prior confirmation of the displayed prompt "YES" it is necessary to substitute the sensor at the end of the conduct by a short-circuit
- **DEF** = 0

6.1.3 SETTING THE REAL TIME CLOCK

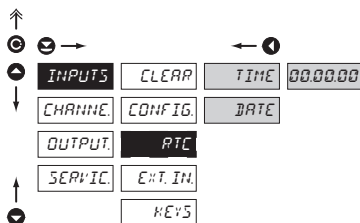

PTC Setting the real time clock (RTC)

TIME Time setting

- format 23.59.59

DATE Date setting

- format DD.MM.YY

6.1.4a EXTERNAL INPUT FUNCTION SELECTION

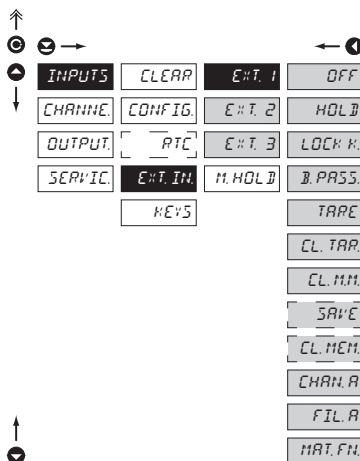

EXT. IN. External input function selection

OFF Input is off

HOLD Activation of HOLD

LOCK K. Locking keys on the instrument

B. PASS. Activation of locking access into programming menu

LIGHT/PROFI

TARE Tare activation

CL. TARE Tare resetting

CL. MIN. Resetting min/max value

SAVE Activation of measured data record in instrument memory

CL. MEM. Clearing memory for option FAST/RTC

CHAN. A Displaying value of "Channel A"

FIL. A Displaying value of "Channel A" after being processed by digital filters

MAT. FN. Displaying value of "Mathematical function"

- **DEF** EXT. 1 > HOLD
- **DEF** EXT. 2 > LOCK K.
- **DEF** EXT. 3 > TARE

*

Procedure identical for EXT. 2 and EXT. 3

6. SETTING PROFI

6.1.4b SELECTION OF FUNCTION "HOLD"

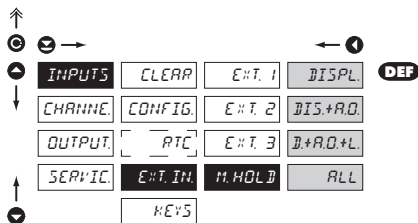

M.HOLD Selection of function "HOLD"

DISPL.	"HOLD" locks only the value displayed
DIS.+R.D.	"HOLD" locks the value displayed and on AO
D.+R.D.+L.	"HOLD" locks the value displayed, on AO and limit evaluation
ALL	"HOLD" locks the entire instrument

6.1.5a OPTIONAL ACCESSORY FUNCTIONS OF THE KEYS

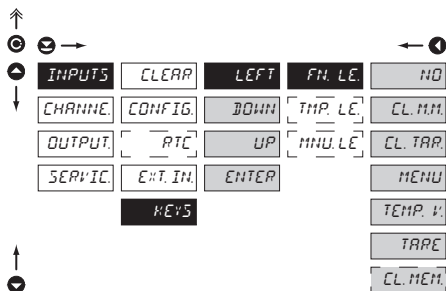

FN.LE. Assigning further functions to instrument keys

- „FN.LE.“ > executive functions

NO	Key has no further function
CL.MM.	Resetting min/max value
CL.TAR.	Tare resetting
MENU	Direct access into menu on selected item
TEMP.V.	Temporary projection of selected values
TARE	Tare function activation
CL.MEM.	Clearing memory

- after confirmation of this selection the "MNU.LE." item is displayed on superior menu level, where required selection is performed

- after confirmation of this selection the item "TMP.LE." is displayed on superior menu level, where required selection is performed

- clearing memory with data measured in modes "FAST" or "RTC"

!

Preset values of the control keys **DEF.**

LEFT	Show Tare
UP	Show Max. value
DOWN	Show Min. value
ENTER	w/o function

!

Setting is identical for LEFT, DOWN, UP and ENTER

6.1.5b OPTIONAL ACCESSORY FUNCTIONS OF THE KEYS - TEMPORARY PROJECTION

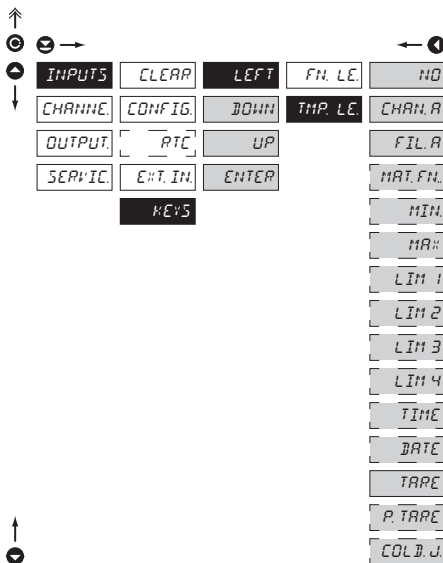
**THP. LE.** Temporary projection of selected item

- „TMP. LE.“> temporary projection of selected values
- “Temporary” projection of selected value is displayed for the time of keystroke
- “Temporary” projection may be switched to permanent by pressing + “Selected key”, this holds until the stroke of any key

NO	Temporary projection is off
CHAN. A	Temporary projection of “Channel A” value
FIL. A	Temporary projection of “Channel A” value after processing digital filters
MAT. FN.	Temporary projection of “Mathematic functions” value
MIN	Temporary projection of “Min. value”
MAX	Temporary projection of “Max. value”
LIM 1	Temporary projection of “Limit 1” value
LIM 2	Temporary projection of “Limit 2” value
LIM 3	Temporary projection of “Limit 3” value
LIM 4	Temporary projection of “Limit 4” value
TIME	Temporary projection of “TIME” value
DATE	Temporary projection of “DATE” value
TARE	Temporary projection of “TARE” value
P. TARE	Temporary projection of “P. TARE” value
COLB. J.	Temporary projection of “CJC” value



Setting is identical for LEFT, DOWN, UP and ENTER

6. SETTING PROFI

6.1.5c

OPTIONAL ACCESSORY FUNCTIONS OF THE KEYS - DIRECT ACCESS TO ITEM

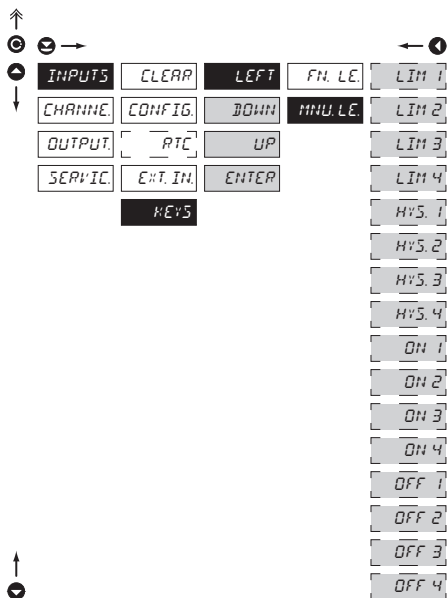

MENU. LE Assigning access to selected menu item

LIM 1	Direct access to item "LIM 1"
LIM 2	Direct access to item "LIM 2"
LIM 3	Direct access to item "LIM 3"
LIM 4	Direct access to item "LIM 4"
HYS. 1	Direct access to item "HYS. 1"
HYS. 2	Direct access to item "HYS. 2"
HYS. 3	Direct access to item "HYS. 3"
HYS. 4	Direct access to item "HYS. 4"
ON 1	Direct access to item "ON 1"
ON 2	Direct access to item "ON 2"
ON 3	Direct access to item "ON 3"
ON 4	Direct access to item "ON 4"
OFF 1	Direct access to item "OFF 1"
OFF 2	Direct access to item "OFF 2"
OFF 3	Direct access to item "OFF 3"
OFF 4	Direct access to item "OFF 4"

!
Setting is identical for LEFT, DOWN, UP and ENTER



6. SETTING PROFI

6.2 SETTING "PROFI" - CHANNELS

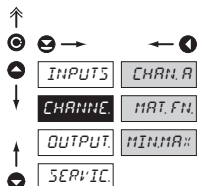

The primary instrument parameters are set in this menu

CHAN. A	Setting parameters of measuring "Channel A"
MAT. FN.	Setting parameters of mathematic functions
MINMA:	Selection of access and evaluation of Min/max value

6.2.1a DISPLAY PROJECTION

DC PM DU OHM

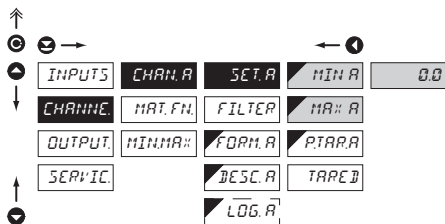

SET. A Setting display projection

MIN A Setting display projection for minimum value of input signal

- range of the setting: -99999...999999

- DEF = 0.0

MA: A Setting display projection for maximum value of input signal

- range of the setting: -99999...999999

- DEF = 100.0

6.2.1b SETTING FIXED TARE

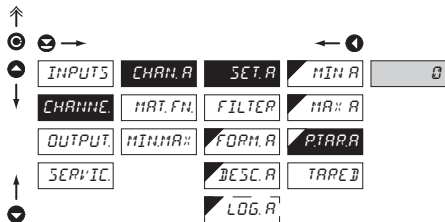

P. TAR. A Setting "Fixed tare" value

- setting is designed for the event when it is necessary to firmly shift the beginning of the range by known size

- when setting (P. TAR. A ≠ 0) is in effect, display does not show the "T" symbol

- range of the setting: -99999...999999

- DEF = 0

6.2.1c SELECTING WHERE TARE WILL BE APPLIED

**TARE: A** Selecting the position of tare

CHAN: A The value will be tared before linearisation and digital filter

FIL: A The value will be tared after linearisation and digital filter

6.2.1d DIGITAL FILTERS

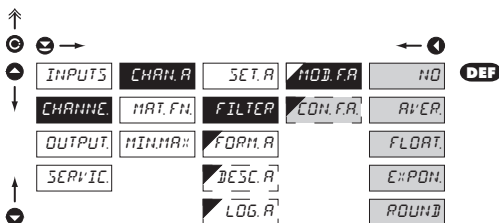
**MOD: FA** Selection of digital filters

- at times it is useful for better user projection of data on display to modify it mathematically and properly , wherefore the following filters may be used

NO Filters are off

AVER Measured data average

- arithmetic average from given number („CON. FA“) of measured values
- range 2...100

FLOAT Selection of floating filter

- floating arithmetic average from given number („CON. FA“) of measured data and updates with each measured value
- range 2...30

E: PDM Selection of exponential filter

- integration filter of first prvnho grade with time constant („CON. FA“) measurement
- range 2...100

ROUND Measured value rounding

- is entered by any number, which determines the projection step (e.g. „CON. FA“ = 2,5 > display 0, 2,5, 5,...)

CON: FA Setting constants

- this menu item is always displayed after selection of particular type of filter

DEF = 2

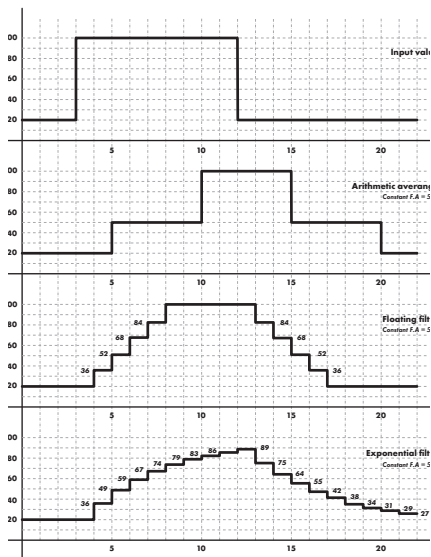

6. SETTING PROFI

6.2.1e PROJECTION FORMAT - POSITIONING OF DECIMAL POINT

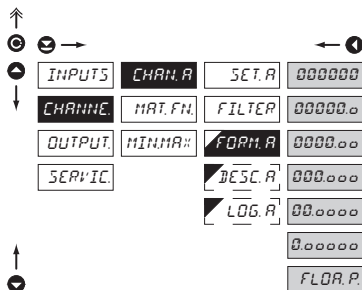

FORM.A Selection of decimal point

The instrument allows for classic projection of a number with positioning of the DP as well as projection with floating DP, allowing to display a number in its most exact form „FLOAT.P.“

000000 Setting DP - XXXXXX.

00000.0 Setting DP - XXXXX.x

DEF > RTD T/C

0000.00 Setting DP - XXXX.xx

DEF > DC PM DU OHM

000.000 Setting DP - XXX.xxx

00.0000 Setting DP - XX.xxxx

0.00000 Setting DP - X.xxxxx

FLOOR.P Floating DP

6.2.1f PROJECTION OF DESCRIPTION - THE MEASURING UNITS

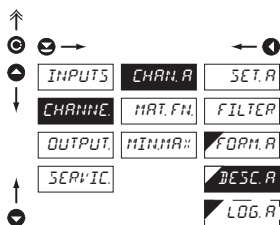

DESC.A Setting projection of descrpt. for "Channel A"

- projection of measured data may be extended (at the expense of the number of displayed places) by two characters for description
- description is set by shifted ASCII code, when two first places show the set description and two last characters their code in period 0...95
- description is cancelled by code 00

RTD T/C DEF = °C

DC PM DU OHM DEF = none



Table of signs on page 83



6.2.1g SELECTION OF STORING DATA INTO INSTRUMENT MEMORY

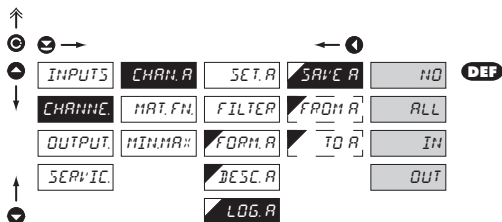

LOG.R Selection of storing data into instrument memory

- by selection in this item you allow to register values into instrument memory
- another setting in item "OUTPUT.>MEMORY" (not in standard experiment)

NO Measured data is not stored

ALL Measured data is stored in memory

IN Only data measured within the set interval is stored in memory

OUT Only data measured outside the set interval is stored in memory

FROM.R Setting the initial interval value

- setting range: -99999...999999

TO.R Setting the final interval value

- setting range: -99999...999999

6. SETTING PROFI

6.2.2a

MATHEMATIC FUNCTIONS

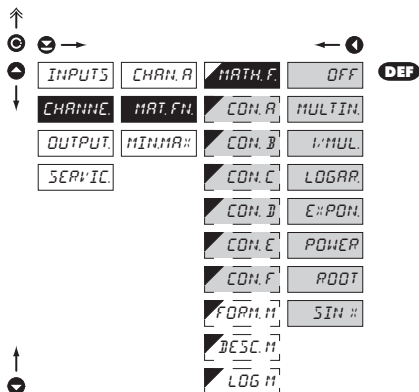

MATH.F. Selection of mathematic functions

OFF Mathematic functions are off

MULTIN. Multinomial

$$4x^3 \square Bx^4 \square Cx^3 \square Dx^2 \square Ex \square F$$

1/MUL. 1/x

$$\frac{A}{x^2} \square \frac{B}{x^4} \square \frac{C}{x^3} \square \frac{D}{x^2} \square \frac{E}{x} \square F$$

LOGAR. Logarithm

$$4 \square \ln \square \frac{Bx \square C}{Dx \square E} \square F$$

E:POW. Exponential

$$4 \square e^{\frac{Bx \square C}{Dx \square E}} \square F$$

POWER Power

$$4 \square Bx \square C^{Dx \square E} \square F$$

ROOT Root

$$4 \square \sqrt{\frac{Bx \square C}{Dx \square E}} \square F$$

SIN # Sin x

$$4 \sin^5 x \square B \sin^4 x \square C \sin^3 x \square D \sin^2 x$$

$$\square E \sin x \square F$$

CON. # Setting constants for calculation of mat.functions

- this menu is displayed only after selection of given mathematic function

6.2.2b MATHEMATIC FUNCTIONS - DECIMAL POINT

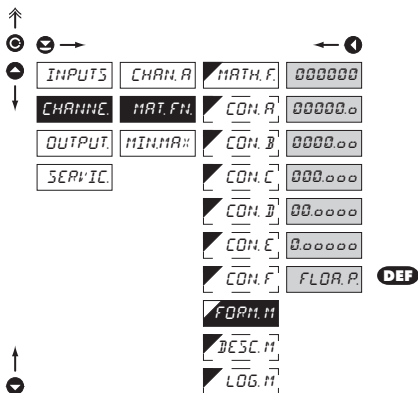
**FORM.H** Selection of decimal point

- the instrument allows for classic projection of a number with positioning of the DP as well as projection with floating DP, allowing to display a number in its most exact form „F.LOAR.P.“

000000	Setting DP - XXXXXX.
00000.0	Setting DP - XXXXX.x
0000.00	Setting DP - XXXX.xx
000.000	Setting DP - XXX.xxx
00.0000	Setting DP - XX.xxxx
0.00000	Setting DP - X.xxxxx
F.LOAR.P.	Floating DP

- **DEF**

6.2.2c MATHEMATIC FUNCTIONS - MEASURING UNITS

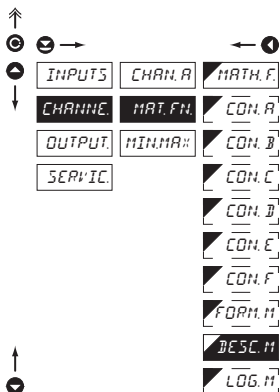
**DESC.H** Setting projection of description for "MAT. FN."

- projection of measured data may be extended (at the expense of the number of displayed places) by two characters for description
- description is set by shifted ASCII code, when two first places show the set description and two last characters their code in period 0...95
- description is cancelled by code 00

- **DEF** = no description

! Table of signs on page 83

6. SETTING PROFI

6.2.2d

MATHEMATIC FUNCTIONS - SELECTION OF STORING DATA INTO INSTRUMENT MEMORY

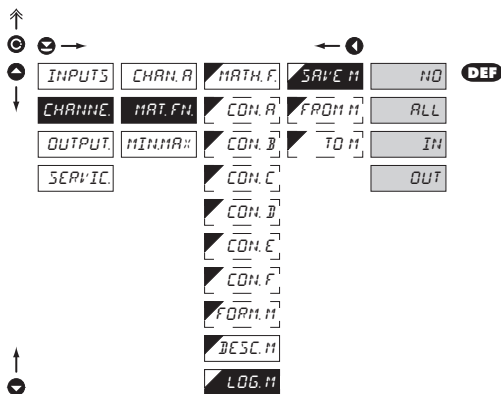

LOG.M Selection of storing data into instrument memory

- by selection in this item you allow to register values into instrument memory
- another setting in item "OUTPUT.>MEMORY" (not in standard experiment)

NO	Measured data is not stored
ALL	Measured data is stored in memory
IN	Only data measured within the set interval is stored in memory
OUT	Only data measured outside the set interval is stored in memory

FROM.M Setting the initial interval value

- setting range: -99999...999999

TO.M Setting the final interval value

- setting range: -99999...999999

6.2.3

SELECTION OF EVALUATION OF MIN/MAX VALUE

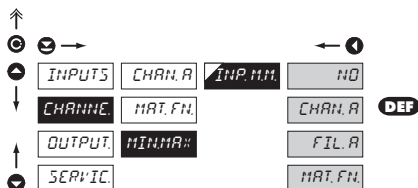

INP.M Selection of evaluation of min/max value

- selection of value from which the min/max value will be calculated

NO	Evaluation of min/max value is off
CHAN.A	From "Channel A"
FIL.A	From "Channel A" after digital filters processing
MAT.FN	From "Mathematic functions"



6. SETTING PROFI

6.3 SETTING „PROFI“ - OUTPUTS

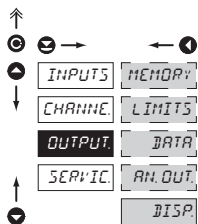

In this menu it is possible to set parameters of the instrument output signals

MEMORY	Setting data logging into memory
LIMITS	Setting type and parameters of limits
DATA	Setting type and parameters of data output
AN_OUT	Setting type and parameters of analog output
DISP	Setting display projection and brightness

6.3.1a SELECTION OF MODE OF DATA LOGGING INTO INSTRUMENT MEMORY

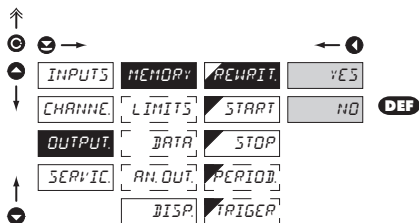

REWRIT Selection of the mode of data logging

- selection of the mode in the event of full instrument memory

NO	Rewriting values prohibited
YES	Rewriting values permitted, the oldest get rewritten by the latest

6.3.1b SETTING DATA LOGGING INTO INSTRUMENT MEMORY - RTC

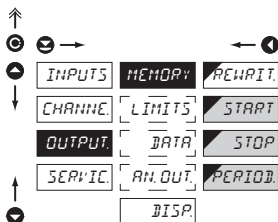

RTC

The lowest recording rate possible is once a day, the highest is every second. Under exceptional circumstances it is possible to set the rate to 8 times per second by entering the recording period as 00:00:00. However, this mode is not recommended due to the memory overload. Recordings are realised in a timeframe of one day and are repeated periodically every following day. Recordings can take place either inside or outside of selected time intervals. The duration of re-writing can be determined by the number of channels recorded as well as by the recording rate.

START Start of data logging into instrument memory

- time format HH.MM.SS

STOP Stop data logging into instrument memory

- time format HH.MM.SS

PERIOD Period of data logging into instrument memory

- determines the period in which values will be logged in an interval delimited by the time set under items START and STOP
- time format HH.MM.SS
- records are made on a daily basis in selected interval and period
- item not displayed if "SAVE" is selected in menu (INPUT > EXT. IN.)

6.3.1c SETTING DATA LOGGING INTO INSTRUMENT MEMORY - FAST

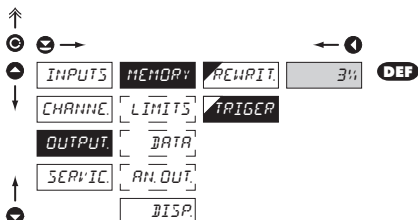

TRIGGER Setting logging data into inst. memory

- logging data into inst. memory is governed by the following selection, which determines how many percent of the memory is reserved for data logging prior to initiation of trigger impulse
- initialization is on ext. input or button
- setting in range 1...100 %
- when setting 100 %, datalogging works in the mode ROLL > data keep getting rewritten in cycles

1. Memory initialization

- clear memory (ext.input, button)
- LED "M" flashes, after reading TRIGGER (%) memory is permanently shining. In ROLL flashes constantly.

2. Triggering

- external input, button
- after the memory LED is full "M" turns off
- in the ROLL mode the trigger ends datalogging and LED turns off

3. Termination

- ext. input, button or reading data via RS

FAST

The memory operates on the basis of memory oscilloscope. Select an area of 0...100% of the memory capacity (100% represents 8192 individual recordings for a single channel measurement). This area is filled cyclically up to the point when the recording starts (activated by the front panel button or by an external input). When the remaining memory capacity fills up the recording stops. A new recording is possible after the deletion of the latest recording. It is possible to abort a recording before its completion by reading out the data.

6. SETTING PROFI



MODE > HYSTER • FROM - TO • DOSING

DESCRIPTION OF RELAY FUNCTION

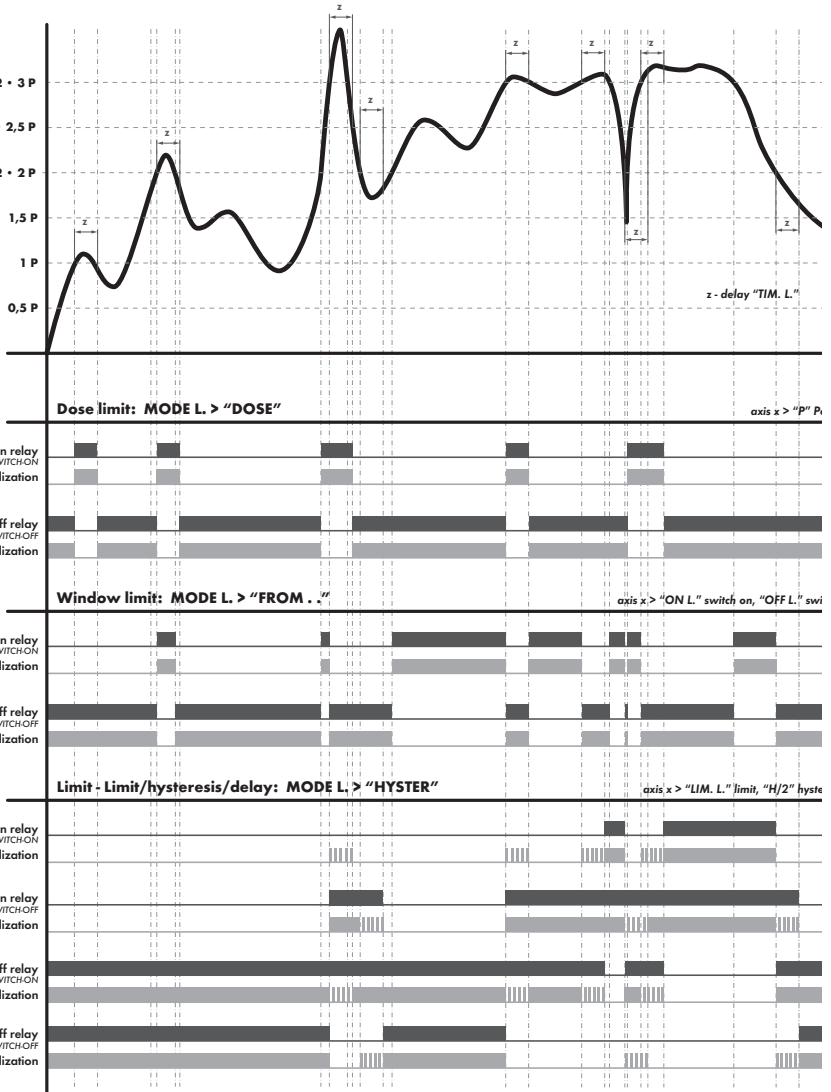

6.3.2a SELECTION OF INPUT FOR LIMITS EVALUATION

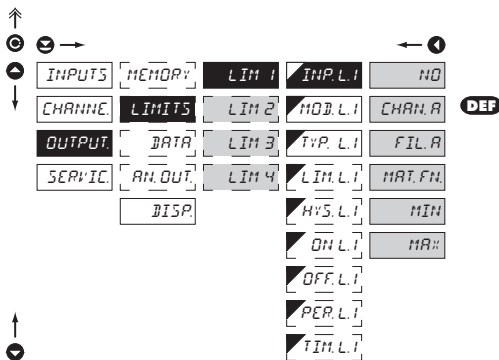
**INP.L1** Selection evaluation of limits

- selection of value from which the limit will be evaluated

- NO** Limit evaluation is off
- CHAN.A** Limit evaluation from "Channel A"
- FIL.A** Limit evaluation from "Channel A" after digital filters processing
- MAT.FN.** Limit evaluation from "Mathematic functions"
- MIN** Limit evaluation from "Min. value"
- MAX** Limit evaluation from "Max. value"

Setting is identical for LIM 1, LIM 2, LIM 3 and LIM 4

6.3.2b SELECTION OF TYPE OF LIMIT

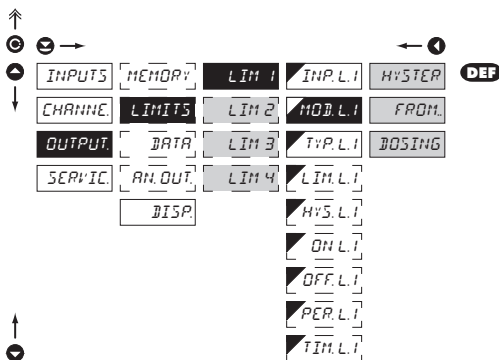
**MOD.L1** Selection the type of limit

- HYSTER** Limit is in mode "Limit, hysteresis, delay"
 - FROM.** Frame limit
 - DOSING** Dose limit (periodic)
- for this mode the parameters of "LIM.L1" are set, at which the limit will shall react, "HYS.L1" the hysteresis range around the limit (LIM±1/2HYS) and time "TIM.L1" determining the delay of relay switch-on
- for this mode the parameters are set for interval "ON.L1" the relay switch-on and "OFF.L1" the relay switch-off
- for this mode the parameters are set for "PER.L1" determining the limit value as well as its multiples at which the output is active and "TIM.L2" indicating the time during which is the output active

Setting is identical for LIM 1, LIM 2, LIM 3 and LIM 4

6. SETTING PROFI

6.3.2c SELECTION OF TYPE OF OUTPUT

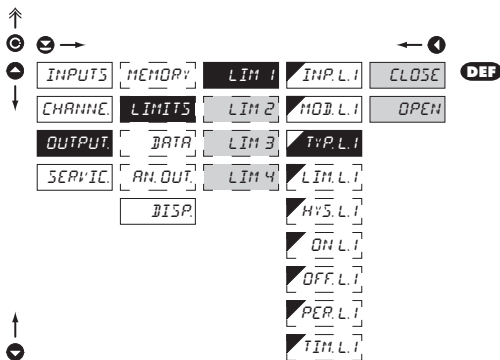

TYPE.L.1 Selection of type of output

CLOSE Output switches on when condition is met

OPEN Output switches off when condition is met

Setting is identical for LIM 1, LIM 2, LIM 3 and LIM 4

6.3.2d SETTING VALUES FOR LIMITS EVALUATION

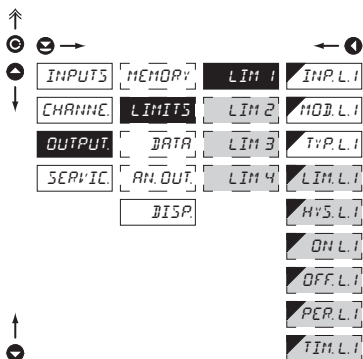

LIM.L.1 Setting limit for switch-on

- for type "HYSTER"

HYS.L.1 Setting hysteresis

- for type "HYSTER"
- indicates the range around the limit (in both directions, LIM. $\pm 1/2$ HYS.)

ON.L.1 Setting the outset of the interval of limit switch-on

- for type "FROM.."

OFF.L.1 Setting the end of the interval of limit switch-on

- for type "FROM.."

PER.L.1 Setting the period of limit switch-on

- for type "DOSING"

TIM.L.1 Setting the time switch-on of the limit

- for type "HYSTER" and "DOSING"
- setting within the range: $\pm 0...99.9$ s
- positive time > relay switches on after crossing the limit (LIM. L.1) and the set time (TIM. L.1)
- negative time > relay switches off after crossing the limit (LIM. L.1) and the set negative time (TIM. L.1)

Setting is identical for LIM 1, LIM 2, LIM 3 and LIM 4

6.3.3a SELECTION OF DATA OUTPUT BAUD RATE

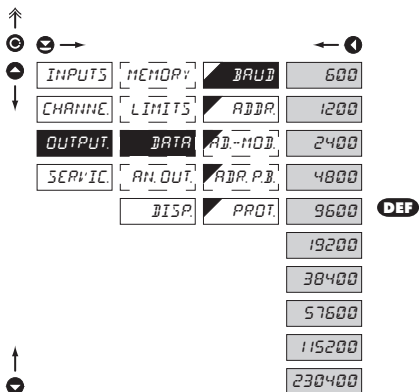
**BAUD** Selection of data output baud rate

600	Rate - 600 Baud
1200	Rate - 1 200 Baud
2400	Rate - 2 400 Baud
4800	Rate - 4 800 Baud
9600	Rate - 9 600 Baud
19200	Rate - 19 200 Baud
38400	Rate - 38 400 Baud
57600	Rate - 57 600 Baud
115200	Rate - 115 200 Baud
230400	Rate - 230 400 Baud

6.3.3b SETTING INSTRUMENT ADDRESS

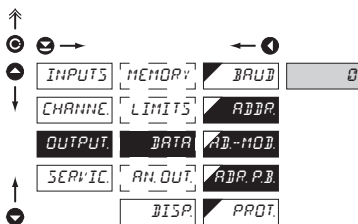
**ADDR** Setting instrument address

- setting in range 0...31
- **DEF** = 00

AD-MOD Setting instrument address - MODBUS

- setting in range 1...247
- **DEF** = 1

ADDR.PB Setting instrument address - PROFIBUS

- setting in range 1..127
- **DEF** = 19

6. SETTING PROFI

6.3.3c SELECTION OF DATA OUTPUT PROTOCOL

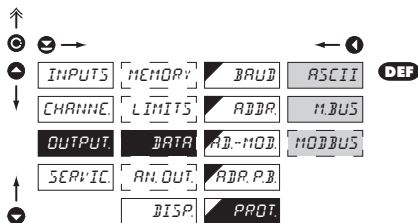

PROT. Selection of the type of analog output

ASCII Data protocol ASCII

M.BUS Data protocol DIN MessBus

MODBUS Data protocol MODBUS-RTU

- option is available only for RS 485

6.3.4a SELECTION OF INPUT FOR ANALOG OUTPUT

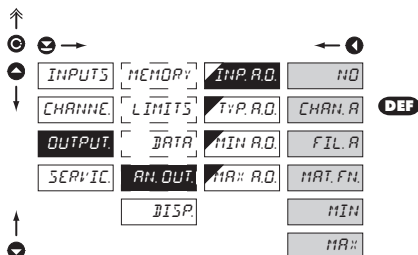

IMP.A.O. Selection evaluation analog output

- selection of value from which the analog output will be evaluated

NO AO evaluation is off

CHAN.A AO evaluation from "Channel A"

FIL.A AO evaluation from "Channel A" after digital filters processing

MAT.FN. AO evaluation from "Math. functions"

MIN AO evaluation from "Min. value"

MAX AO evaluation from "Max. value"

6.3.4b SELECTION OF THE TYPE OF ANALOG OUTPUT

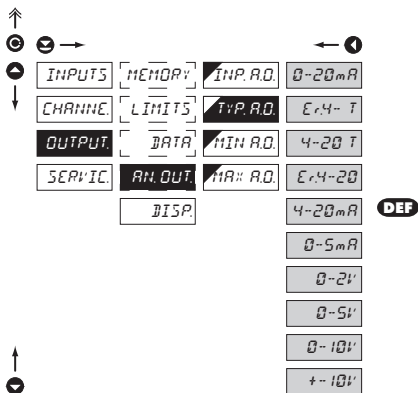
**TYP. R.D.** Selection of the type of analog output

0-20mA Type - 0...20 mA

E.r.4- I Type: 4...20 mA with indication

- with broken loop detection and indication of error statement (< 3,6 mA)

4-20 I Type: 4...20 mA with indication

- with broken loop detection (< 3,6 mA)

E.r.4-20 Type: 4...20 mA with indication

- with indic. of error statement (< 3,6 mA)

4-20mA Type - 4...20 mA

0-5mA Type - 0...5 mA

0-2V Type - 0...2 V

0-5V Type - 0...5 V

0-10V Type - 0...10 V

+/- 10V Type - ±10 V

6.3.4c SETTING THE ANALOG OUTPUT RANGE

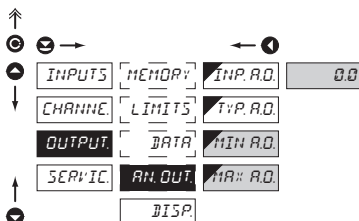
**AN. OUT.** Setting the analog output range

- analog output is isolated and its value corresponds with displayed data. It is fully programmable, i.e. it allows to assign the AO limit points to two arbitrary points of the entire measuring range

MIN. R.D. Assigning the display value to the beginning of the AO range

- range of the setting: -99999...999999

- **DEF** = 0

MAX. R.D. Assigning the display value to the end of the AO range

- range of the setting: -99999...999999

- **DEF** = 100

6. SETTING PROFI

6.3.5a SELECTION OF INPUT FOR DISPLAY PROJECTION

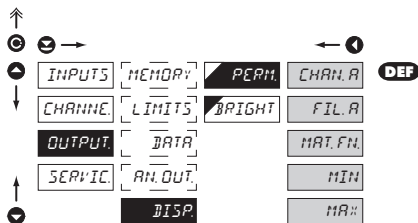

PERM. Selection display projection

selection of value which will be shown on the instrument display

CHAN. A	Projection of values from "Channel A"
FIL. A	Projection of values from "Channel A" after digital filters processing
MAT. FN.	Projection of values from "Math. functions"
MIN	Projection of values from "Min. value"
MAX	Projection of values from "Max. value"

6.3.5b SELECTION OF DISPLAY BRIGHTNESS

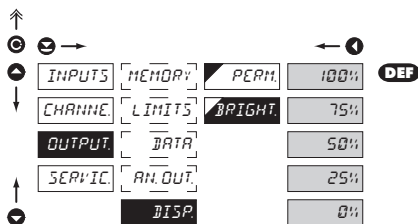

BRIGHT Selection of display brightness

- by selecting display brightness we may appropriately react to light conditions in place of instrument location

0%	Display is off
25%	Display brightness - 25%
50%	Display brightness - 50%
75%	Display brightness - 75%
100%	Display brightness - 100%



6. SETTING PROFI

6.4 SETTING "PROFI" - SERVICE

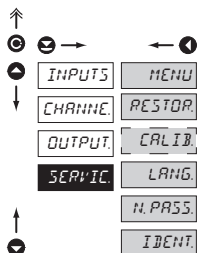

The instrument service functions are set in this menu

MENU	Selection of menu type LIGHT/PROFI
RESTOR	Restore instrument manufacture setting and calibration
CALIB	Input range calibration for „DU“ version
LANG	Language version of instrument menu
N. PASS	Setting new access password
IDENT	Instrument identification

6.4.1 SELECTION OF TYPE OF PROGRAMMING MENU

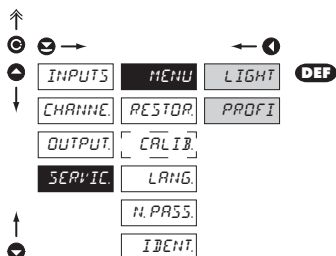

MENU Selection of menu type - LIGHT/PROFI

- enables setting the menu complexity according to user needs and skills

LIGHT Active LIGHT menu

- simple programming menu, contains only items necessary for configuration and instrument setting
- linear menu > items one after another

PROFI Active PROFI menu

- complete programming menu for expert users
- tree menu



Change of setting is valid upon next access into menu

6.4.2 RESTORATION OF MANUFACTURE SETTING

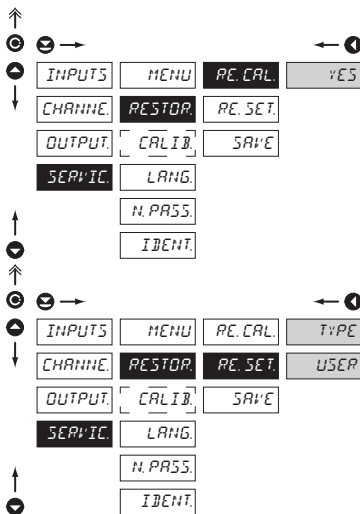
**RESTOR.** Restoration of manufacture setting

- in the event of error setting or calibration, manufacture setting may be restored

RE.CAL. Restoration of manufacture calibration of the instrument

- prior executing the changes you will be asked to confirm you selection „YES“

RE.SET. Restoration of instrument manufacture setting**TYPE** Restoration of instrument manufacture setting

- generating the manufacture setting for currently selected type of instrument (items marked DEF)

USER Restoration of instrument user setting

- generating the instrument user setting, i.e. setting stored under SERVICE/RESTOR/SAVE

SAVE Save instrument user setting

- storing the user setting allows the operator to restore it in future if needed



After restoration the instrument switches off for couple seconds

JOBS PERFORMED

RESTORE

CALIBRATION SETTING

JOBS PERFORMED	RESTORE	
	CALIBRATION	SETTING
cancels USER menu rights	✓	✓
deletes table of items order in USER - LIGHT menu	✓	✓
adds items from manufacture to LIGHT menu	✓	✓
deletes data stored in FLASH	✓	✓
cancels or linearization tables	✓	✓
clears tare	✓	✓
restore manufacture calibration	✓	✗
restore manufacture setting	✗	✓

6. SETTING PROFI

6.4.3 CALIBRATION - INPUT RANGE

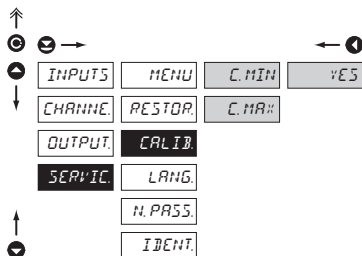
DU

CALIB Input range calibration

- when "C. MIN" is displayed, move the potentiometer traveller to the required minimum position and confirm by „Enter“, calibration is confirmed by "YES"
- when "C. MAX" is displayed, move the potentiometer traveller to required maximum position and confirm by „Enter“, calibration is confirmed by "YES"

6.4.4 SELECTION OF INSTRUMENT MENU LANGUAGE VERSION

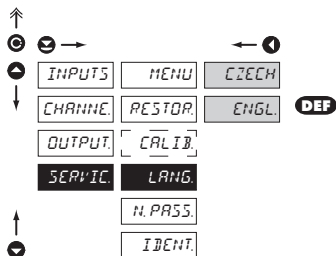

LANG Selection of instrument menu language version

- CZECH** Instrument menu is in Czech
- ENGL** Instrument menu is in English

6.4.5 SETTING NEW ACCESS PASSWORD

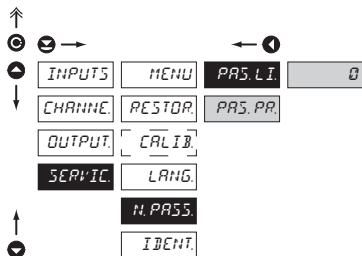

H. PASS Setting new password for access to LIGHT and PROFI menu

- this option allows to change the numeric code, which blocks the access into LIGHT and PROFI menu.
- numeric code range: 0...9999
- universal passwords in the event of loss: LIGHT Menu > „8177“ PROFI Menu > „7915“

6.4.6 INSTRUMENT IDENTIFICATION

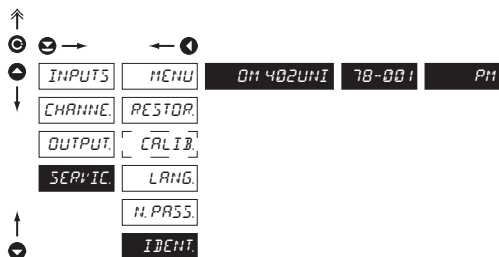
**IDENT.** Projection of instrument SW version

- display shows type identification of the instrument, SW number, SW version and current input setting (Mode)
- if the SW version reads a letter on first position, it is a customer SW

IDENT.	Pos.	Description
	1.	type of instrument
	2.	SW: number - version
	3.	the input type

SETTING USER

For user operation

Menu items are set by the user (Profi/Light) as per request

Access is not password protected

Optional menu structure either tree (PROFI) or linear (LIGHT)

7.0 SETTING ITEMS INTO "USER" MENU

- **USER** menu is designed for users who need to change only several items of the setting without the option to change the primary instrument setting (e.g. repeated change of limit setting)
- there are no items from manufacture permitted in **USER** menu
- on items indicated by inverse triangle  **LIM 1**
- setting may be performed in **LIGHT** or **PROFI** menu, with the **USER** menu then overtaking the given menu structure

Setting

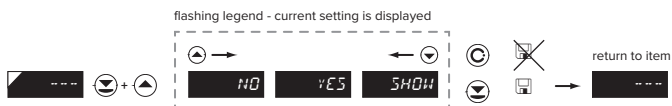

NO

item will not be displayed in USER menu

YES

item will be displayed in USER menu with editing option

SHOW

item will be solely displayed in USER menu

Setting sequence of items in "USER" menu

In compiling USER menu from active LIGHT menu the items (max. 10) may be assigned a sequence, in which they will be projected in the menu

setting projection sequence

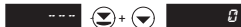

Example of ranking the order of menu items in the "USER" menu

In this example we want to have a direct access to menu items Limit 1 and Limit 2 (example show is for the Light menu, but can equally be used in the Profi menu).

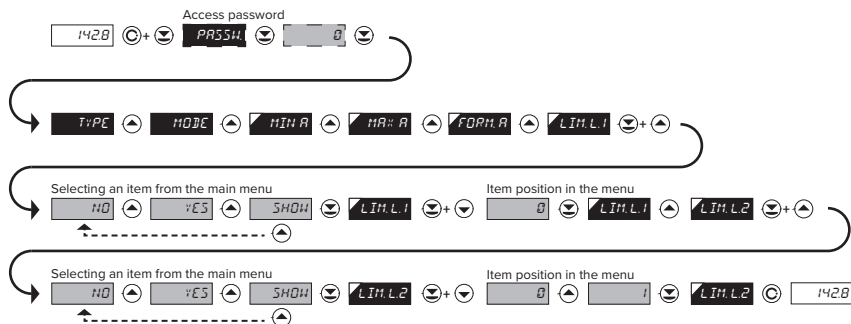

The result of this setting is that when the **Ⓢ** button is pressed, the display will read „LIM L.1“. By pressing **Ⓢ** button you confirm your selection and then you can set the desired limit value, or by pressing the **⬆** button you can go to setting of „LIM. L.2“ where you can proceed identically as with Limit one.

You can exit the setting by pressing the **Ⓢ** button by which you store the latest setting and pressing the **Ⓢ** button will take you back to the measuring mode

6. METHOD OF MEASURING THE CJC

Instrument with input for temperature measurement with thermocouple allows to set two types of measurement of cold junction.

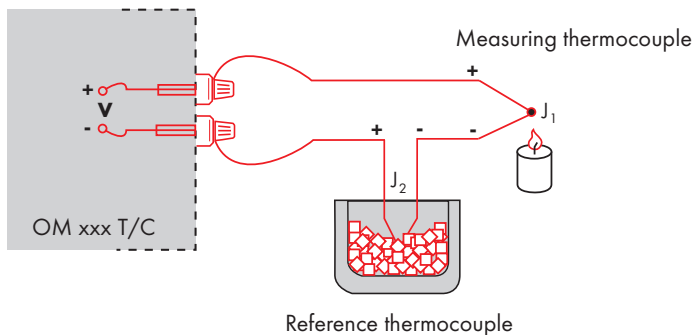

WITH REFERENCE THERMOCOUPLE

- a reference thermocouple may be located in the same place as the measuring instrument or in place with stable temperature/compensation box
- when measuring with reference thermocouple set *CONNECT* in the instrument menu to *INT2TC* or *E#T2TC*
- when using a thermostat (a compensation box or environment with constant temperature) set in the instrument menu *CJC.TEM*, its temperature (applies for setting *CONNECT*, to *E#T2TC*)
- if the reference thermocouple is located in the same environment as the measuring instrument then set in the instrument menu *CONNECT* to *INT2TC*. Based on this selection the measurement of the ambient temperature is performed by a sensor located in the instrument terminal board

WITHOUT REFERENCE THERMOCOUPLE

- inaccuracy originating from the creation of dissimilar thermocouples on the transition point terminal/conductor of the thermocouple is not compensated for in the instrument
- when measuring without reference thermocouple set *CONNECT* in the instrument menu to *INT1TC* or *E#T1TC*
- when measuring temperature without reference thermocouple the error in measured data may be as much as 10°C (applies for setting *CONNECT*, to *E#T1TC*)

10. ERROR STATEMENTS

ERROR	CAUSE	ELIMINATION
<i>E. d. U_n</i>	Number is too small (large negative) to be displayed	change DP setting, channel constant setting
<i>E. d. D_{rx}</i>	Number is too large to be displayed	change DP setting, channel constant setting
<i>E. L. U_n</i>	Number is outside the table range	increase table values, change input setting (channel constant setting)
<i>E. L. D_{rx}</i>	Number is outside the table range	increase table values, change input setting (channel constant setting)
<i>E. I. U_n</i>	Input quantity is smaller than permitted input quantity range	change input signal value or input (range) setting
<i>E. I. D_{rx}</i>	Input quantity is larger than permitted input quantity range	change input signal value or input (range) setting
<i>E. H_{rx}</i>	A part of the instrument does not work properly	send the instrument for repair
<i>E. EE</i>	Data in EEPROM corrupted	perform restoration of manufacture setting, upon repeated error statement send instrument for repair
<i>E. SET</i>	Data in EEPROM outside the range	perform restoration of manufacture setting, upon repeated error statement send instrument for repair
<i>E. CLR</i>	Memory was empty (presetting carried out)	upon repeated error statement send instrument for repair, possible failure in calibration
<i>E. OUT</i>	Analogue output current loop disconnected	check wire connection

The instrument allows to add two descriptive characters to the classic numeric formats (at the expense of the number of displayed places). The setting is performed by means of a shifted ASCII code. Upon modification the first two places display the entered characters and the last two places the code of the relevant symbol from 0 to 95. Numeric value of given character equals the sum of the numbers on both axes of the table.

Description is cancelled by entering characters with code 00

	0	1	2	3	4	5	6	7		0	1	2	3	4	5	6	7
0		7	"	#	\$	%	&	'	0	!	"	#	\$	%	&	'	
8	()	*	+	,	-	.	/	8	()	*	+	,	-	.	/
16	0	1	2	3	4	5	6	7	16	0	1	2	3	4	5	6	7
24	8	9	VA	Vr	<	=	>	?	24	8	9	VA	Vr	<	=	>	?
32	P	A	B	C	D	E	F	G	32	@	A	B	C	D	E	F	G
40	H	I	J	K	L	M	N	O	40	H	I	J	K	L	M	N	O
48	P	Q	R	S	T	U	V	W	48	P	Q	R	S	T	U	V	W
56	X	Y	Z	[\]	^	_	56	X	Y	Z	[\]	^	_
64	`	a	b	c	d	e	f	g	64	`	a	b	c	d	e	f	g
72	h	i	j	k	l	m	n	o	72	h	i	j	k	l	m	n	o
80	p	q	r	s	t	u	v	w	80	p	q	r	s	t	u	v	w
88	x	y	z	{		}	~		88	x	y	z	{		}	~	

12. TECHNICAL DATA

INPUT

range is adjustable

±60 mV	>100 MΩ	DC
±150 mV	>100 MΩ	Input U
±300 mV	>100 MΩ	Input U
±1200 mV	>100 MΩ	Input U

range is adjustable

±0,1 A	< 300 mV	DC - option "A"
±0,25 A	< 300 mV	Input I
±0,5 A	< 300 mV	Input I
±1 A	< 30 mV	Input I
±5 A	< 150 mV	Input I
±100 V	20 MΩ	Input U
±250 V	20 MΩ	Input U
±500 V	20 MΩ	Input U

range is adjustable

0/4...20 mA	< 400 mV	PM
±2 V	1 MΩ	Input U
±5 V	1 MΩ	Input U
±10 V	1 MΩ	Input U
±40 V	1 MΩ	Input U

range is adjustable

0...100 Ω		OHM
0...1 kΩ		
0...10 kΩ		
0...100 kΩ		
Autorange		

Connection:

2, 3 or 4 wire

Pt xxxx

-200°...850°C

RTD

Pt xxxx/3910 ppm

-200°...1 100°C

Ni xxxx

-50°...250°C

Cu/4260 ppm

-50°...200°C

Cu/4280 ppm

-200°...200°C

Type Pt:

EU > 100/500/1 000 Ω, with 3 850 ppm/°C

US > 100 Ω, with 3 920 ppm/°C

RU > 50/100 Ω, with 3 910 ppm/°C

Type Ni

Ni 1 000/ Ni 10 000 with 5 000/6 180 ppm/°C

Type Cu

Cu 500/ Cu 100 with 4 260/4 280 ppm/°C

Connection

2, 3 or 4 wire

range is adjustable in configuration menu

T/C

Type

J (Fe-CuNi)

-200°...900°C

K (NiCr-Ni)

-200°...1 300°C

T (Cu-CuNi)

-200°...400°C

E (NiCr-CuNi)

-200°...690°C

B (PtRh30-PtRh6) 300°...1 820°C

S (PtRh10-Pt)

-50°...1 760°C

R (Pt13Rh-Pt)

-50°...1 740°C

N (Omegalloy)

-200°...1 300°C

L (Fe-CuNi)

-200°...900°C

Voltage of lin. pot.

2,5 VDC/6 mA

DU

min. potentiometer resistance is 500 Ω

PROJECTION

Display

999999, intensive red or green
14 segment LED, digit height 14 mm

Projection

±9999 (-99999...999999)

Decimal point

adjustable - in menu

Brightness

adjustable - in menu

INSTRUMENT ACCURACY

TC

50 ppm/°C

Accuracy

±0,1 % of range + 1 digit
±0,15 % of range + 1 digit
Above accuracies apply for projection 9999

RTD, T/C

Resolution

0,01°/0,1°/1°

RTD

Rate

0,1...40 measurements/s**

Overload capacity

10x (t < 100 ms) not for 500 V and 5 A,
2x (long-term)

Linearisation

by linear interpolation in 38 points
- solely via OM Link

Digital filters

Averaging, Floating average, Exponential filter, Rounding

Comp. of conduct

max. 40 Ω/100 Ω

RTD

Comp. of cold junc.

adjustable

T/C

Functions

Tare - display resetting
Hold - stop measuring (at contact)
Lock - control key locking
MM - min/max value
Mathematic functions

OM Link

company communication interface for setting, operation and update of instrument SW

Watch-dog

reset after 400 ms

Calibration

at 25°C and 40% of r.h.

COMPARATOR

Type

digital, adjustable in menu

Mode

Hysteresis, From, Dosing

Limita

-999999...999999

Hysteresis

0...999999

Delay

0...99,9 s

Outputs

2x relays with switch-on contact (Form A)
(230 VAC/30 VDC, 3 A)*
2x relays with switch-off contact (Form C)
(230 VAC/50 VDC, 3 A)*
2x SSR (250 VAC/1 A)*
2x/4x open collector (30 VDC/100 mA)
2x bistabil relays (250 VAC/250 VDC, 3 A/0,3 A)*
1/8 HP 277 VAC, 1/10 HP 125 V, Pilot Duty D300

Relay

* values apply for resistance load

DATA OUTPUTS

Protocols	ASCII, DIN MessBus, MODBUS, PROBUS
Data format	8 bit + no parity + 1 stop bit (ASCII) 7 bit + even parity + 1 stop bit (MessBus)
Rate	600...230 400 Baud 9 600 Baud...12 Mbaud (PROFIBUS)
RS 232	isolated, two-way communication
RS 485	isolated, two-way communication, addressing (max. 31 instruments)
PROFIBUS	Data protocol SIEMENS

ANALOG OUTPUTS

Type	isolated, programmable with 16 bits D/A converter, analogoutput corresponds with displayed data, type and range are adjustable
Non-linearity	0,1% of range
TC	15 ppm/°C
Rate	response to change of value < 1 ms
Voltage	0...2 V/5 V/10 V/±10 V
Current	0...5/20 mA/4...20 mA compensation of conduct to 500 Ω/12V or 1 000 Ω/24V

MEASURED DATA RECORD

Type RTC	time-controlled logging of measured data into instrument memory, allows to log up to 250 000 values
Type FAST	fast data logging into instrument memory, allows to log up to 8 000 values at a rate of 40 records/s
Transmission	via data output RS 232/485 or via OM Link

EXCITATION

Adjustable	5...24 VDC/max. 1,2 W, isolated
------------	---------------------------------

POWER SUPPLY

Options	10...30 V AC/DC, max. 13,5 VA, PF ≥ 0,4, $I_{TP} < 40$ A/1 ms, isolated - fuse inside (T 4000 mA) 80...250 V AC/DC, max. 13,5 VA, PF ≥ 0,4, $I_{TP} < 40$ A/1 ms, isolated - fuse inside (T 6300 mA)
---------	---------------------------------------------------------------------------------------------------------------------------------------------------------------------------------------------------------------------

MECHANIC PROPERTIES

Material	Noryl GFN2 SE1, incombustible UL 94 V-1
Dimensions	96 x 48 x 120 mm
Panel cut-out	90,5 x 45 mm

OPERATING CONDITIONS

Connection:	connector terminal board, conductor cross-section <1,5 mm ² / <2,5 mm ²
Stabilisation period	within 15 minutes after switch-on
Working temp.	-20°...60°C
Storage temp.	-20°...85°C
Cover	IP64 (front panel only)
Construction	safety class I
Dielectric strength	4 kVAC after 1 min between supply and input 4 kVAC after 1 min between supply and data/analog output 4 kVAC after 1 min between supply and relay output 2,5 kVAC after 1 min between supply and data/analog output
Overvoltage cat.:	EN 61010-1, A2
Insulation resist.	for pollution degree II, measurement cat. III instrum.power supply > 670 V (PI), 300 V (DI) Input/output > 300 V (PI), 150 (DI)
EMC	EN 61326-1
Seismic resistance	IEC 980: 1993, par. 6

**Table of rate of measurement in relation to number of inputs

Channels/Rate	40	20	10	5	2	1	0,5	0,2	0,1
No.of channels: 1 (Type: DC, PM, DU)	40,00	20,00	10,00	5,00	2,00	1,00	0,50	0,20	0,10
No.of channels: 2	5,00	2,50	1,25	1,00	0,62	0,38	0,22	0,09	0,05
No.of channels: 3	3,33	1,66	0,83	0,66	0,42	0,26	0,14	0,06	0,03
No.of channels: 4	2,50	1,25	0,62	0,50	0,31	0,19	0,11	0,05	0,02
No.of channels: 1 (Type: OHM, RTD, T/C)	5,00	2,50	1,25	1,00	0,62	0,38	0,22	0,09	0,05
No.of channels: 2	3,33	1,66	0,83	0,66	0,42	0,26	0,14	0,06	0,03
No.of channels: 3	2,50	1,25	0,62	0,50	0,31	0,19	0,11	0,05	0,02
No.of channels: 4	2,00	1,00	0,50	0,40	0,25	0,15	0,08	0,04	0,02

13. INSTRUMENT DIMENSIONS AND INSTALLATION

Front view



Panel cut

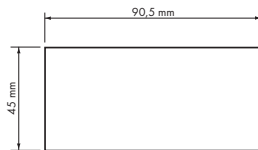

Side view

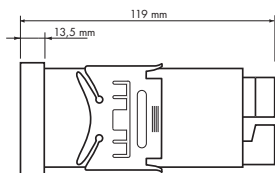

Panel thickness: 0,5...20 r

INSTRUMENT INSTALLATION

1. insert the instrument into the panel cut-out
2. fit both travellers on the box
3. press the travellers close to the panel

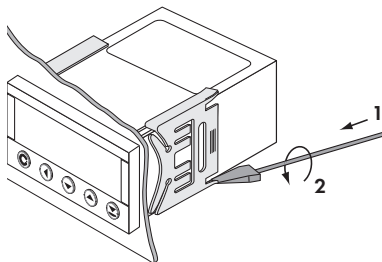
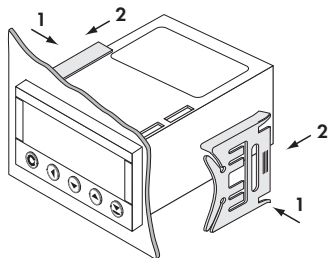

INSTRUMENT DISASSEMBLY

1. slide a screw driver under the traveller wing
2. turn the screw driver and remove the traveller
3. take the instrument out of the panel



Product **OM 402UNI** **A**
Type
Manufacturing No.
Date of sale

WARRANTY

A guarantee period of 60 months from the date of sale to the user applies to this instrument.
Defects occurring during this period due to manufacture error or due to material faults shall be eliminated free of charge.

For quality, function and construction of the instrument the guarantee shall apply provided that the instrument was connected and used in compliance with the instructions for use.

The guarantee shall not apply to defects caused by:

- mechanic damage
- transportation
- intervention of unqualified person incl. the user
- unavoidable event
- other unprofessional interventions

The manufacturer performs guarantee and post.guarantee repairs unless provided for otherwise.



YEARS

Stamp, signature

NOTE





NOTE

Company: **ORBIT MERRET, spol. s r.o.**
Kláňova 81/141, 142 00 Prague 4, Czech Republic, IDNo.: 00551309

Manufactured: **ORBIT MERRET, spol. s r.o.**
Vodňanská 675/30, 198 00 Prague 9, Czech Republic

declares at its explicit responsibility that the product presented hereunder meets all technical requirements, is safe for use when utilised under the terms and conditions determined by ORBIT MERRET, spol.s r.o. and that our company has taken all measures to ensure conformity of all products of the types referred-to hereunder, which are being brought out to the market, with technical documentation and requirements of the appurtenant Czech statutory orders.

Product: Programmable panel instrument

Type **OM 402**

Version: UNI, PWR

This has been designed and manufactured in line with requirements of:

Low-voltage electrical equipment (directive no. 2014/35/EU)
Electromagnetic compatibility (directive no. 2014/30/EU)

The product qualities are in conformity with harmonized standard:

El. safety: EN 61010-1

EMC: EN 61326-1

Electronic measuring, control and laboratory devices
– Requirements for EMC "Industrial use"

EN 50131-1, chap. 14 and chap. 15, EN 50130-4, chap. 7, EN 50130-4, chap. 8, (EN 61000-4-11, ed. 2), EN 50130-4, chap. 9 (EN 61000-4-2), EN 50130-4, chap. 10, (EN 61000-4-3, ed. 2), EN 50130-4, chap. 11 (EN 61000-4-6), EN 50130-4, chap. 12, (EN 61000-4-4, ed. 2), EN 50130-4, chap. 13 (EN 61000-4-5), EN 61000-4-8, EN 61000-4-9, EN 61000-6-1, EN 61000-6-2, EN 55022, chap. 5 and chap. 6

Seismic resistance: IEC 980: 1993, par. 6

The product is furnished with CE label issued in 2006

As documentation serve the protocoles of authorized and accredited organizations:

EMC MO CR, Testing institute of technical devices, protocol no. 80/6-46/2006 of 03/03/2006

MO CR, Testing institute of technical devices, protocol no. EMI.80/6-333/2006 of 15/01/2007

Seismic resistance VOP-026 Stemberk, protocol no.: 6430-16/2007 of 07/02/2007

Place and date of issue: Prague, 19. Juli 2010

Miroslav Hackl
Company representative



ORBIT MERRET, spol. s r. o.
Vodňanská 675/30
198 00 Praha 9
Czech Republic

tel.: +420 281 040 200
fax.: +420 281 040 299
orbit@merret.eu
www.orbit.merret.eu

