

# LINEAR POTENTIOMETERS

## OM 472DU



- 4 <sup>3</sup>/<sub>4</sub> digit programmable projection
- Input for linear potentiometers
- Mathematic functions, Digital filters
- Size of DIN 96 x 48 mm
- Power supply 230 VAC

### Options

Comparators • Data output • Universal analogue output • Real time  
Power supply 24 VAC, 110 VAC, 10...30 VDC

### Description

The OM 472DU model is a 4 <sup>3</sup>/<sub>4</sub> digit panel programmable instrument for linear potentiometers designed for direct projection of signal in required units.

The instrument is based on an 8-bit controller with very precise A/D converter, that secures high accuracy, stability and easy operation of the instrument.

### Standard functions

#### Programmable display projection

Setting	automatic, optional projection on the display may be set for both limit values of the linear potentiometer in „CM“
Projection	±49999

#### Digital filters

Floating average	from 2...30 measurements
Exponen. average	from 2...128 measurements
n-th value	from 2...255 measurements
Radius of insensitiv.	band of suppressed change of measured value

#### Mathematic functions

Min./max. value	registration of min./max. value reached during measurements
Tare	designed to reset display upon non-zero input signal
Top value	the display shows only max. (min.) value for a selected time period
Round up/down	setting the projection step for display
Math. operations	polynome, 1/x, logarithm, exponential, power, root, sin x

#### External control

Hold	display/instrument blocking
Lock	control keys blocking
Tare	tare activation
Resetting MM	resetting min/max value to zero

### Operation

The instrument is set and controlled by five control keys located on the front panel. All programmable settings of the instrument are realised in two adjusting modes.

Configuration menu	(hereinafter referred to as CM) is protected by an optional number code and contains complete instrument setting
User menu	may contain arbitrary programming settings defined in „CM“ with another selective restriction (see, change)

All programmable parameters are stored in the EEPROM memory (they hold even after the instrument is switched off). The measured units may be projected on the display.

### Options

**Comparators** are assigned to monitor one, two, three or four limit values with relay output. The user may select limits regime: LIMIT/DOSING/FROM-TO. The limits have adjustable hysteresis within the full range of the display as well as selectable delay of the switch-on in the range of 0...99,9 s. Reaching the preset limits is signalled by LED and simultaneously by the switch-on of the relevant relay.

**Data outputs** are for their rate and accuracy suitable for transmission of the measured data for further projection or directly into the control systems. We offer an isolated RS232 and RS485 with the DIN MessBus/ASCII protocol.

**Analogue outputs** will find their place in applications where further evaluating or processing of measured data is required in external devices. We offer universal analogue output with the option of selection of the type of output - voltage/current. The value of analogue output corresponds with the displayed data and its type and range are selectable in CM.

**Real time** is an internal time control of data collection. It is suitable everywhere where it is necessary to register measured data in a given time segment. Up to 65 000 values may be stored in the instrument's memory. Data transmission into PC via serial interface RS232/485.

## Technical data

### MEASURING RANGE

Power sup.for lin.pot.: 2 VDC/6 mA  
minimum resistance of linear potentiometer is 500 Ohm

### PROJECTION

Display:  $\pm 49999$ , red or green 14-segment LED, digit height 14 mm  
Decimal point: adjustable - in Configuration menu  
Brightness: adjustable - in Configuration/User menu

### INSTRUMENT ACCURACY

Tempco: 60 ppm/°C  
Accuracy:  $\pm 0,1$  % of range  
Rate: 1...100 measurements/s  
Input filters: floating (2-30) and exp. average, radius of insensitiveness, n-th value (2-255)  
Function: offset, min./max. value, Tare, top value, Hold, Lock, Math. operations  
External control: INP 1, INP 2  
- adjustable fce: Hold, Lock, Tare, resetting  
Real time: 15 ppm/°C  
time-date-display value (max. 65000 data), transmission of stored data RS 232 at 25°C and 40 % r.h.  
Calibration:

### COMPARATOR

Type: digital, adjustable in programming mode, contact switch-on < 30 ms  
Limit 1... 4  
Hysteresis: 0...9999  
Delay: 0...99,9 s  
Outputs: 4 relays with switching contact (250 VAC/50 VDC, 3 A)  
upon request SSR (250 VAC, 1 A) or open collector may be fitted

### DATA OUTPUTS

Data format: rate 600...38 400 Baud, 7 bit + even parity + 1 stop bit (DIN MessBus),  
8 bit + no parity + 1 stop bit (ASCII)  
RS 232: isolated  
RS 485: isolated, addressing (up to 31 instruments)

### ANALOGUE OUTPUTS

Type: isolated, programmable with resolution max. 10 000 points, analogue output corresponds with the displayed data, output type and range are selectable in CM  
Non-linearity: 0,2 % of range  
Tempco: 100 ppm/°C  
Rate: response to change of value < 40 ms  
Voltage: 0...2 V/5 V/10 V  
Current: 0...5 mA/20 mA/4...20 mA (compensation of conduct up to 600 Ohm)

### POWER SUPPLY

24/110/230 VAC, 50/60 Hz,  $\pm 10$  %, 7,5 VA  
10...30 VDC/max. 1,2 A, (24 VDC/350 mA), isolated  
- power supply is protected by a fuse inside the instruments

### MECHANIC PROPERTIES

Material: Noryl GFN2 SE1, incombustible UL 94 V-I  
Dimensions: 96 x 48 x 154 mm  
Panel cut: 90,5 x 45 mm

### OPERATING CONDITIONS

Connection: connector terminal board, conductor section up to 1,5/2,5 mm<sup>2</sup>  
Stabilization period: within 15 minutes after switch-on  
Working temperature: 0°...60°C  
Storage temperature: -10°...85°C  
Covering: IP65 (front panel only)  
Construction: safety class II  
Electrical safety: EN 61010-1, A2  
Overvoltage category: for pollution degree II  
III. - instrument power supply, relay outputs (300 V)  
II. - input, output (300 V)  
EMC: EN 61000-3-2+A12; EN 61000-4-2, 3, 4, 5, 8, 11; EN 55022, A1, A2

## Connection

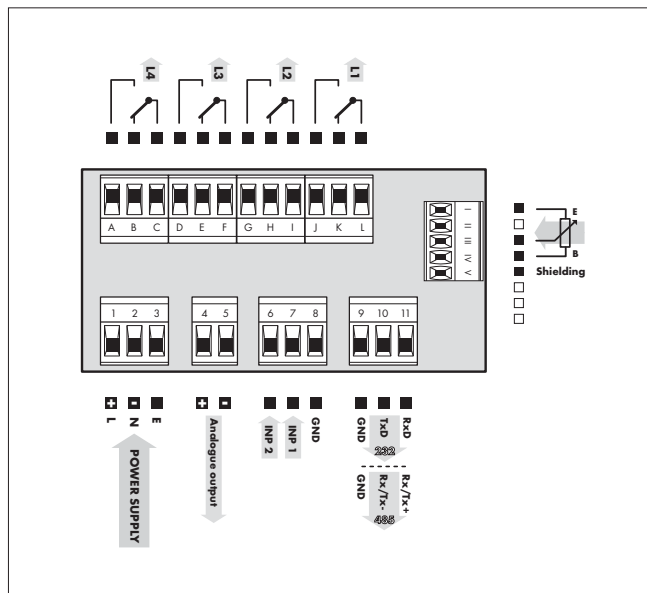

## Dimensions

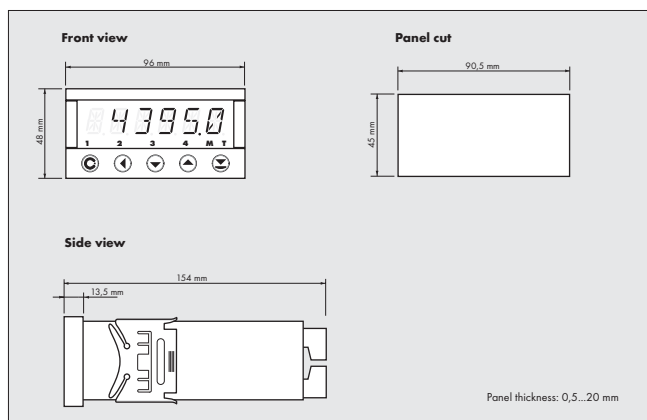

## Order code

