



# **OM 653UQC**

---

**6 DIGIT PROGRAMMABLE**

**IMPULSE COUNTER/FREQUENCY METER  
STOPWATCH/TIMER**



## SAFETY INSTRUCTIONS

Please, read the enclosed safety instructions carefully and observe them!  
These instruments should be safeguarded by isolated or common fuses (breakers)!  
For safety information the EN 61 010-1 + A2 standard must be observed.  
This instrument is not explosion-safe!

## TECHNICAL DATA

Measuring instruments of the OM 653 series conform to the European regulation No. 73/23/EHS and No. 2004/108/EC.

They are up to the following European:  
EN 61010-1 Electrical safety  
EN 61326-1 Electrical measurement, EMC standards „Industrial use“

The instruments are applicable for unlimited use in agricultural and industrial areas.

## CONNECTION

Supply of energy from the main line has to be isolated from the measuring leads.





### ORBIT MERRET, spol. s r.o.

Vodňanská 675/30  
198 00 Prague 9  
Czech Republic

Tel: +420 - 281 040 200  
Fax: +420 - 281 040 299  
e-mail: orbit@merret.cz  
www.orbit.merret.cz



1.	Contens .....	3
2.	Instrument description .....	4
3.	Instrument connection .....	6
	Comparison levels .....	8
4.	Instrument setting .....	10
	Symbols used in the instructions .....	12
	Setting the DP and the (-) sing .....	12
	Control keys functions .....	13
	Configuration of „User“ menu items .....	13
5.	Setting “LIGHT” menu .....	
5.0	Description “LIGHT” menu .....	14
	Access to menu .....	16
	Setting initial value .....	16
	Selection of instrument measuring mode .....	17
	Selection of digital input filter .....	17
	Selection of control START  .....	18
	Selection of control STOP  .....	18
	Automatic setting of the inputs .....	19
	Setting multiplying constant, offset and projection format - channel Counter .....	19
	Setting multiplying constant, offset and projection format - channel Frequency .....	21
	Setting limits .....	24
	Setting analog output .....	26
	Setting display projection .....	28
	Setting the menu type (LIGHT/PROFI) .....	28
	Restoration of manufacture setting .....	29
	Setting new access password .....	30
	Instrument identification .....	30
6.	Setting “PROFI” menu .....	
6.0	Description “PROFI” menu .....	34
6.1	“PROFI” menu - INPUT .....	
6.1.1	Resetting internal values .....	38
6.1.2	Instrument configuration .....	39
6.1.3	Setting external control input .....	46
6.1.4	Setting function of the control key .....	47
6.2	“PROFI” menu - CHANNELS .....	
6.2.1	Setting calibration constants and offset .....	48
6.2.2	Setting digital filter .....	49
6.2.3	Projection format .....	50
6.3	“PROFI” menu - OUTPUTS .....	
6.3.1	Configuration and setting the limits .....	52
6.3.2	Setting data output .....	55
6.3.3	Setting analog output .....	57
6.3.4	Setting display brightness .....	58
6.4	“PROFI” menu - SERVICE .....	
6.4.1	Selection of the type of programming menu .....	60
6.4.2	Restoration of manufacture setting .....	61
6.4.3	Setting new access password .....	61
6.4.4	Instrument identification .....	61
7.	Setting “USER” menu .....	62
8.	Data protocol .....	64
9.	Error statements .....	66
10.	Technical data .....	68
11.	Instrument dimension and installation .....	70
12.	Certificate of guarantee .....	71
	Declaration of conformity .....	72

## 2.1 Description

The OM 653UQC model is a universal 6 digit panel programmable impulse counter/frequencymeter and stopwatch/timer. The instrument is based on an 8-bit microprocessor, which secures high accuracy, stability and easy operation of the instrument.

### Measuring modes

SINGLE	Counter/Frequencymeter
QVADR	Counter/Frequencymeter for IRC sensors
UP/DW	UP/DW Counter/Frequencymeter - used in inputs A, C (direction) and can display count/frequency
UP - DW	UP - DW Counter/Frequencymeter - used in inputs A (UP), C (DW) and can display count/frequency
TIME	Stopwatch
RTC	Timer

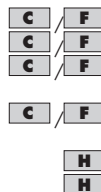

### PROGRAMMABLE PROJECTION

Calibration	calibration coefficient may be set in „CM“ independently for every channel
Projection	-99999...999999 with fixed or floating DP, for measuring modes STOPWATCH/TIMER with the option of setting in format 10/24/60
Measuring channels	two independent functions may be evaluated from each input (Counter/Frequency)
Time base	0,5/1/5/10 s

### DIGITAL FILTERS

Input filter	the instrument enables filtering the input signal and thus suppress unwanted interfering signals (e.g. relay backswings). The parameter set gives maximum feasible measured frequency processed by the instrument, 5/40/100/1 000 Hz
Exponen.average	from 2...100 measurements
Rounding	setting projection step for display

### LINEARIZATION

Linearization	by linear interpolation in 25 points (solely via OM Link) - a single table for frequency, alternatively for for counting pulses when frequency not used
---------------	--

### FUCTIONS

Setting the value	Entering the current count when installing the counter during a counting cycle
Preset	initial non-zero value, unloaded always after instrument resetting
Summation	registration of the number upon shift operation
Tare	designed to reset display upon non-zero input signal
OM Link	company interface for control, setting and instrument update

### EXTERNAL CONTROL

Hold	display/instrument blocking
Lock	locking the control keys for access into Configuration menu
Resetting	resetting/pre-setting the counter
Tare	tare activation
Start/Stop	stopwatch/timer control

## 2.2 Operation

The instrument is set and controlled by five control keys located on the front panel. All programmable settings of the instrument are realized in two adjusting modes:

<b>LIGHT</b>	<b>Simple programming menu</b> - contains only items necessary for instrument setting and is protected by an optional numeral code
<b>PROFI</b>	<b>Complete programming menu</b> - contains complete instrument menu and is protected by an optional numeral code
<b>USER</b>	<b>User programmable menu</b> - may contain arbitrary items selected from programmable menu (LIGHT/PROFI), which determines the authorization (see or change) - access is without password

All programmable parameters are stored in the EEPROM memory (they hold even after the instrument is switched off).

 Complete operation and setting of the instrument may be performed via communication interface OM Link, which is a standard equipment of every instrument.

The operation program is freely available ([www.orbit.merret.cz](http://www.orbit.merret.cz)) and the only requirement is the purchase of OML cable for connecting the instrument to PC. It is manufactured in version RS 232 and USB and is compatible with all ORBIT MERRET instruments.

Another option for connection is with the aid of data output RS 232 or RS 485 (without the need for OML cable).

The OM LINK program version „Standard“ allows you to connect an unlimited number of instruments with the option of visualization and storage in PC.

## 2.3 Extension

**Excitation** is suitable for feeding sensors and converters. It has a galvanic isolation.

**Comparators** are assigned to control two limit values with relay output. The modes: „Hysteresis“ / „Zero and pulse“ can be assigned by user to the first relay and for the second relay it is starting the stopwatch/clock. The limits have adjustable hysteresis as well as selectable delay of the switch-on. Reaching the preset limits is signalled by LED and simultaneously by the switch-on of the relevant relay.

**Data outputs** are for their rate and accuracy suitable for transmission of measured data for further projection or directly into the control systems. We offer an isolated RS232 and RS485 with the ASCII protocol.

**Analog outputs** will find their place in applications where further evaluating or processing of measured data in external devices is required. We offer a universal analog output with the option of selection of output type - voltage/current. The value of analog output corresponds with the displayed data and its type and range are selectable in the programming mode.

**Time backup** by means of RTC circuit is designed for the „TIMER“ measuring mode and secures time measuring even if the instrument is switched-off (without display projection).

The instrument supply leads should not be in proximity of the incoming low-potential signals. Contactors, motors with larger input power should not be in proximity of the instrument. The leads into the instrument input (measured quantity) should be in sufficient distance from all power leads and appliances. Provided this cannot be secured it is necessary to use shielded leads with connection to ground (bracket E). The instruments are tested in compliance with standards for use in industrial area, yet we recommend to abide by the above mentioned principles.

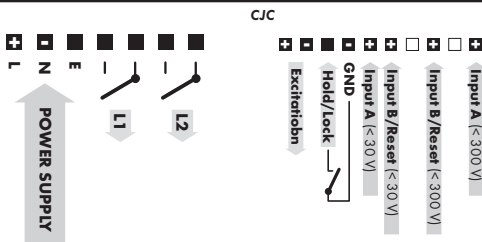
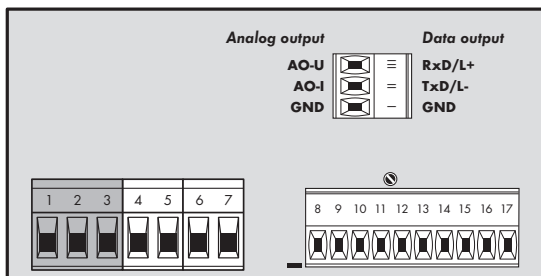

**!**  
Grounding on bracket „E“ has to be connected at all times

**!**  
Sensors with PNP or NPN output have always only one „fixed“ level and therefore it is extremely important the leads are properly shielded and separated from possible sources of interference. If interference occurs, it can be included in the measurement. One of the ways of eliminating this possible problem is applying an input signal filter in the Menu.

## CONNECTION

	Description	Connection
<b>Input A (&lt; 30 V)</b>	input signal < 43 V (absolute 60 V)	GND + Input A (< 30 V)
<b>Input A (&lt; 300 V)</b>	input signal < 300 V	GND + Input A (< 300 V)
<b>Input B/Reset (&lt; 30 V)</b>	input signal < 43 V	GND + Resetting (< 30 V)
<b>Input B/Reset (&lt; 300 V)</b>	input signal < 300 V	GND + Resetting (< 300 V)

Function	Description	Control
<b>Optional</b>	According to setting in Menu (see Menu > EXT. IN., p. 46)	upon contact, bracket (no. 11/12)

## FUNCTIONS OF INPUTS ACCORDING TO SELECTED MODE

Mode	Description	Functions of inputs
SINGLE	Pulse counter/Frequency counter	Input A, Resetting (Input B)
QUADR.	Pulse counter/ Frequency counter for IRC sensors	Input A + Input B, Resetting is possible on terminal 10
UP/DW	UP or DW Pulse counter/Frequency counter	Input A, Input B - determines direction (Hi = UP, Lo = DW) Resetting is possible on terminal 10
UP-DW	UP/DW Pulse counter/Frequency counter	Input A (UP), Input B (DW), Resetting is possible on terminal 10
TIME	Stopwatch Clock	Input A, Resetting (Input B)
RTC	Stopwatch Clock with time back up	Input A, Resetting (Input B)

### Sensor connection

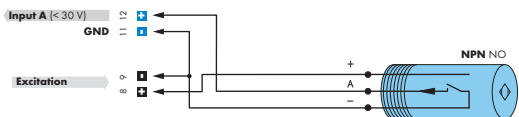
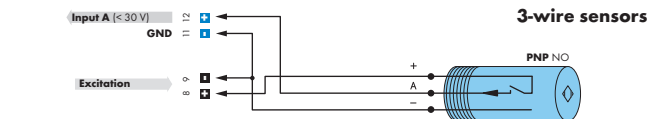
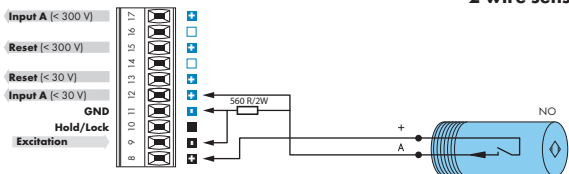

Table of comparison levels

Input	Type of input	Maximum input voltage (Level A, C)	Maximum comparison levels	
			L > H	H > L
Input A Resetting (< 30 V)	NPN, Contact	xxx	0,5 V	4,5 V
	PNP	9,7 V	0,5 V	4,5 V
	PNP	14,4 V	1,0 V	9,0 V
	PNP	19,2 V	1,5 V	13,3 V
	PNP	23,9 V	2,0 V	17,8 V
	PNP	28,7 V	2,5 V	22,1 V
	PNP	33,5 V	3,0 V	26,6 V
	PNP	38,3 V	3,4 V	31,0 V
	PNP	43,0 V	3,9 V	35,5 V
Input A Resetting (< 300 V)	NPN, Contact	!!! prohibited !!!		
	PNP	84 V	4,9 V	39,8 V
	PNP	128 V	9,2 V	78,0 V
	PNP	170 V	13,6 V	117,8 V
	PNP	211 V	17,8 V	156,0 V
	PNP	253 V	22,3 V	195,8 V
	PNP	295 V	26,5 V	234,1 V
	PNP	301 V	30,9 V	273,9 V





PROFI

SETTING

*profi*

LIGHT

SETTING

*light*

USER

SETTING

*profi light**user*

- For expert users
- Complete instrument menu
- Access is password protected
- Possibility to arrange items of the „User“ menu
- Tree menu structure

- For trained users
- Only items necessary for instrument setting
- Access is password protected
- Possibility to arrange items of the „User“ menu
- Linear menu structure

- For user operation
- Menu items are set by the user (Profi/Light) as per request
- Access is not password protected
- Optional menu structure either tree (PROFI) or linear (LIGHT)

**4.1 Setting**

The instrument is set and controlled by five control keys located on the front panel. All programmable settings of the instrument are performed in three adjusting modes:

- LIGHT**      **Simple programming menu**  
- contains solely items necessary for instrument setting and is protected by optional number code
- PROFI**      **Complete programming menu**  
- contains complete instrument menu and is protected by optional number code
- USER**      **User programming menu**  
- may contain arbitrary items selected from the programming menu (LIGHT/PROFI), which determine the right (see or change)  
- access without password

All programmable parameters are stored in the EEPROM memory (they hold even after the instrument is switched off).

Complete instrument operation and setting may be performed via OM Link communication interface, which is a standard equipment of all instruments.

The operation program is freely accessible ([www.orbit.merret.cz](http://www.orbit.merret.cz)) and the only requirement is the purchase of OML cable to connect the instrument to PC. It is manufactured in version RS 232 and USB and is compatible with all ORBIT MERRET instruments. Another option for connection is with the aid of data output RS 232 or RS 485 (without the need of the OML cable).

Setting and controlling the instrument is performed by means of 5 control keys located on the front panel. With the aid of these keys it is possible to browse through the operation menu and to select and set required values.

### Symbols used in the instructions

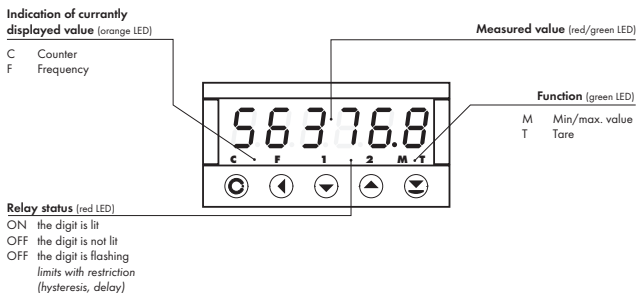

**H** Indicates the setting for given type of instrument

**DEF** values preset from manufacture

symbol indicates a flashing light (symbol)

inverted triangle indicates the item that can be placed in USER menu

broken line indicates a dynamic item, i.e. it is displayed only in particular selection/version

after pressing the key the set value will not be stored

after pressing the key the set value will be stored

**30** continues on page 30

### Setting the decimal point and the minus sign

#### DECIMAL POINT

Its selection in the menu, upon modification of the number to be adjusted it is performed by the control key with transition beyond the highest decade, when the decimal point starts flashing. Positioning is performed by / .

#### THE MINUS SIGN

Setting the minus sign is performed by the key on higher decade. When editing the item subtraction must be made from the current number (e.g.: 013 > , on class 100 > -87)

## Control keys functions

Key	Measurement	Menu	Setting numbers/Selection
	access into USER menu	exit menu w/o saving	transition to next item w/o saving
	programmable key function	return to previous level	move to higher decade
	programmable key function	move to previous item	move down
	programmable key function	move to next item	move up
	programmable key function	confirm selection	setting/selection confirmation
			numeric value is set to zero
	access into LIGHT/PROFI menu		
	direct access into PROFi menu - temporary (remains LIGHT)		
		configuration of an item for "USER" menu	
		determine the sequence of items in "USER - LIGHT" menu	

## Setting items into „USER“ menu

- in LIGHT or PROFi menu
- no items permitted in USER menu from manufacture
- on items marked by inverted triangle



Legend is flashing - current setting is displayed



- item will not be displayed in USER menu
- item will be displayed in USER menu with the option of setting
- item will be solely displayed in USER menu

## 5.0

## Setting "LIGHT"

## LIGHT

## Simple programming menu

- contains only items necessary for instrument setting and is protected by optional numeral code

SETTING LIGHT

*light*

- For capable users
- Only items necessary for instrument setting
- Password protected access
- Possibility to arrange items of the „User“ menu
- Linear menu structure

## Preset from manufacture

Password	"0"
Menu	LIGHT
USR menu	off
Setting the items	<b>DEF</b>

Access password

1428 PASSw. 0

Initial value: **SEt.U.** 0 Measuring range: **NOdE** SInGLE Input filter: **FILtEr** OFF

Made - input: **AStAR.t** COntRct Mode - reset: **AStOP** CLEAR Only for Mode > TIME and RTC

Type of inputs: **SEt.In** Input A: **Az.nPn** Input B: **bz.nPn**

Multiplying constant: **SCAL.C.** 1 Dividing constant: **dLU.C.** 1 Preset: **OFFS.C.** 0 Decimal point: **FDn.P.C.** 00000.0

Multiplying constant: **SCAL.F.** 1 Dividing constant: **dLU.F.** 1 Preset: **OFFS.F.** 0 Decimal point: **FDn.P.F.** 00000.0

Option - Comparator

**INP.L1** COUnt **LIn.L1** 25 **INP.L2** COUnt **LIn.L2** 75

Option - Analog output

**INP.R0** COUnt **tYP.Rw.** 120 **IN.Rw.** 0 **NRH.Rw.** 100

Typ Menu: **INP.d** COUnt Menu type: **NEnt** LIGHT Return to manufacture setting: **FInn** YES Return to user setting: **USEr** YES

New password: **PAS.L1** 0 Identification: **IdEnt.** YES Type of instrument: **00653U9C** version SW: **62-001** input: **SInGLE** 1428 Return to previous measuring mode



Upon delay exceeding 60 s the programming mode is automatically discontinued and the instrument itself restores the measuring mode

1428



PASS



0

Entering access password  
for access into the menu



**PASS.** Access into instrument menu

---

**PAS = 0**  
- access into menu is unrestricted, after releasing keys you automatically move to first item of the menu

**PAS > 0**  
- access into menu is protected by numeric code

Set "PASS." = 42 Example

SET v



0

Setting initial value



**SET v.** Setting initial value

---

- the function allows the user a single-time setting of initial value of display projection
- the instrument is preset from manufacture into "FREQU." measuring mode and unless another mode is set the item remains hidden
- if you need to set initial value for another mode it is necessary to do so upon next access to programming menu > after change of measuring mode

- setting "SET V." is a one-time operation unlike the "OFFSET" option, i.e. after resetting the display value is "0", provided there is no other value set in the "OFFSET" item

**DEF** = 0

Set "SET V." = 233 Example

**!**  
The item „SET V.“ is not projected for measuring mode „FREQU.“



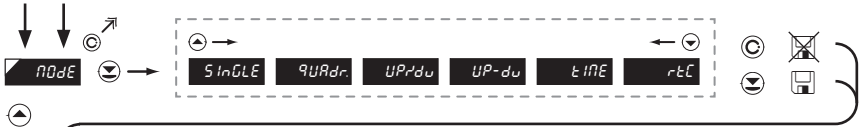

**MODE** Selection of instrument measuring mode

- elementary selection of instrument type

**DEF** = SINGLE

MODE	Menu	Instrument mode
	SINGLE	Counter/Frequencymeter
	QUADR.	Counter/Frequencymeter for IRC
	UP/DW	UP/DW - Counter/Frequencymet.
	UP-DW	UP/DW - Counter/Frequencymet.
	TIME	Stopwatch/timer
	RTC	Stopwatch/backup timer

- detail description of measuring modes is on p. 7 and 40

**Selection of "RTC" mode** **Example**

SINGLE  rEtC  FILTER



**FILTER** Selection of digital filter

- digital filter may suppress unwanted interfering impulses (e.g. relay backswings) on the input signal. The set parameter gives maximum possible frequency, which the instrument processes w/o limitation

- for pulse duty cycle of 50% - equal duration of Hi and Lo level"

**DEF** = OFF

*In this setting the instrument will only register signal of max 100 Hz, higher frequency will be discarded.* **Example**

Filter > 100

OFF  1000  100  40  5  TYPE R

**!**

When accessing upon contact and available maximum input frequency we recommend using filter

Only for measuring mode  
**COUNT. • TIME • RTC**



## **n.StARt** Selection of stopwatch/timer control

- menu for time setting is accessible only in the stopwatch/timer mode

**COntIn** Stopwatch/timer is running constantly if the instrument is turned on

**COntAC** Stopwatch/timer is running upon contact making

**EdGE** Stopwatch/timer is controlled by the priming signal edge

- time is set off by the edge (by the signal passing across the comparing level) and stopped by the next edge

**rUn.StEt** Stopwatch/timer is controlled and reset by the edge of the priming signal

- time is set off by the edge (by the signal

passing across the comparing level) and stopped by the next edge

**CrUn.St** Stopwatch/timer is controlled and reset by the edge of the priming signal

- time is set off by the edge (by the signal passing across the comparing level) and stopped by the next edge

**CLrrUn** Stopwatch/timer is reset and set off by the edge of the priming signal

**CLrUrE** Stopwatch/timer is reset and set off by the edge of the priming signal, the cycle is repeated with every other edge

**rUn** Stopwatch/timer is only set off by the edge

**DEF** = COntAC.

### Selection of stopwatch control > EdGE

Example

**COntAC** **EdGE** **n.StOP**



## **n.StOP** Selection of stopwatch resetting

- menu of the resetting option is accessible only in the stopwatch/timer regime

**DEF** = CLEAR

**CLERr** Stopwatch/timer is reset through input „Clear“

**St.CLr** Stopwatch/timer is stopped and reset through input „Clear“

**StOP** Stopwatch/timer is stopped through input „Clear“

### Selection of type of stopwatch resetting > St. CLr

Example

**CLERr** **St.CLr** **LEwELR**

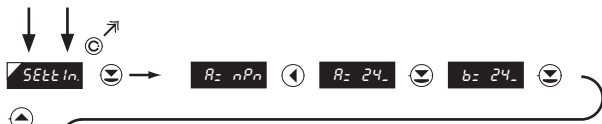

**SEtIn** Automatic setting of the inputs

- it is possible to choose in the menu between automatic or manual setting for input A and B
- for automatic detection the minimum frequency required is 10 Hz

**DEF** = NPN.CON.

- ⬅ start of automatic input setting
- ⬇ manual input setting - down
- ⬆ manual input setting - up
- Ⓜ confirm the setting and proceed to second input (short key stroke) to copy the setting of Input A to Input B (long key stroke)

*In this example application we are using an encoder Woergler, model IB040BM37VB, type PNP powered by the instrument's own excitation of 24 V, reset on contact. **SetIn** > Automatic setting (button "LEFT")*

A: nPn    A: 24.    b: nPn    SCALC



**SCALC** Setting multiplying constant - Channel Counter

- calibration constant serves for calculation of the input value to required display value
- by entering minus value direction of the calculation is changed, i.e. we count down
- range: -0,00001...999999

**DEF** = 1

*Sensor is applied to a shaft equipped with a rotating pin (1 imp./o) and ratio of 1:3* *Example*

1    dU.C

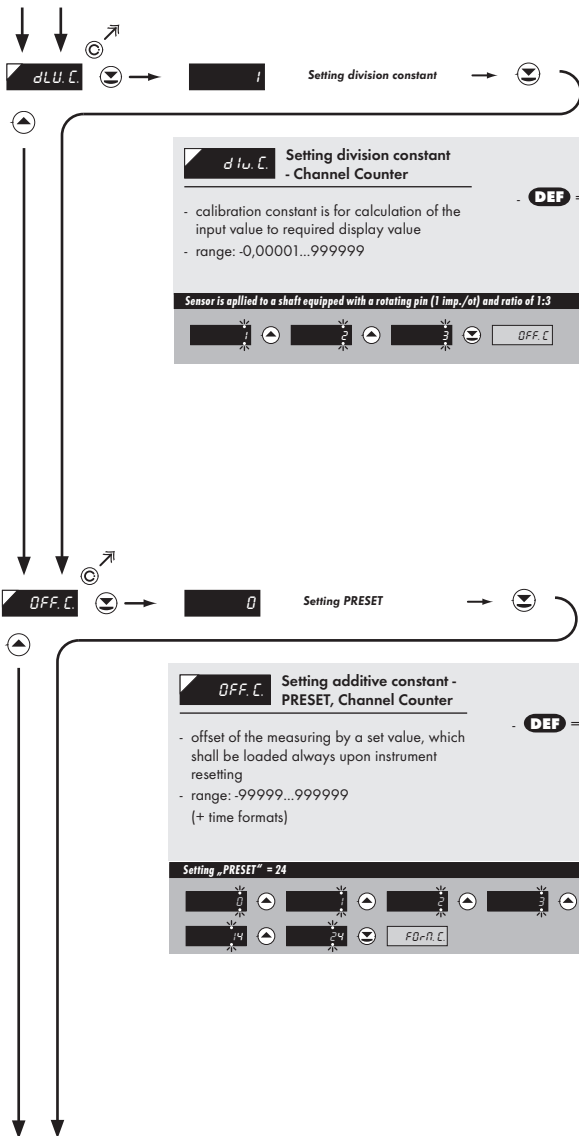

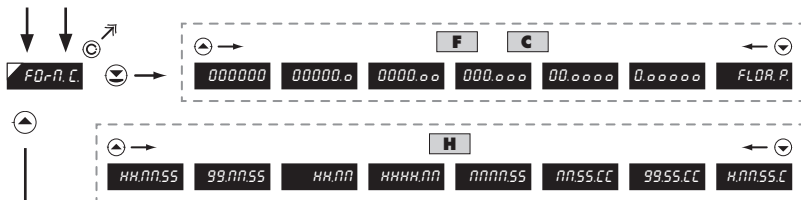

**FD-P.C.** Selection of projection format - Channel Counter

- instrument enables classical projection of number with fixed position of decimal point as well as projection with floating allowing for projection of number in its most precise form „FLOA. P.“
- for measuring modes „TIME“ and „RTC“ special time formats are preset

DEF = 000000  
DEF = HH.MM.SS **H**

Projection of DP on display > 00000.0 Example

000000 00000.0 SCAL.F



**SCAL.F.** Setting multiplying constant - Channel Freque.

- calibration constant serves for calculation of the input value to required display value
- by entering minus value direction of the calculation is changed, i.e. we count down
- range: -0,00001...999999
- DEF = 1

Sensor is applied to a shaft equipped with a rotating pin (1 imp./o) and ratio of 1:3 which is rotating at 3753 revs./min., (3753:60:3=20,85), SCALE > 20,85 Example

05  
95 85 085 0085 1085 2085  
02085 002085 002085 002085 002085 d l w. F



**dLU.F.** Setting division constant - Channel Frequency

- DEF = 1

- calibration constant is for calculation of the input value to required display value
- range: -0,00001...999999

*On the display we want to see speed as revolutions/s. It is necessary to divide the figure by 60 (1 minute=60 s), It is possible to enter the resulting value in to the multiplication constant, dLU.D. > 60* Example



**OFF.F.** Setting additive constant - PRESET, Channel Freque.

- DEF = 0

- offset of the measuring by a set value, which shall be loaded always upon instrument resetting
- range: -99999...999999

**Setting „PRESET“ = 24** Example

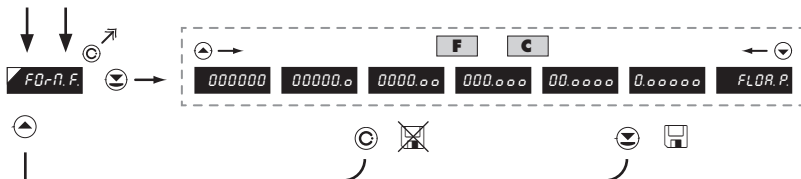

FD-P.F.

**Selection of projection format - Channel Freque.**

- instrument enables classical projection of number with fixed position of decimal point as well as projection with floating allowing fo projection of number in its most precise form „FLOA. P.“

DEF = 000000

---

**Projection of DP on display > 00000.0**
Example

000000

▲

00000.0

▼

InP d

\* subsequent menu item depends on instrument equipment

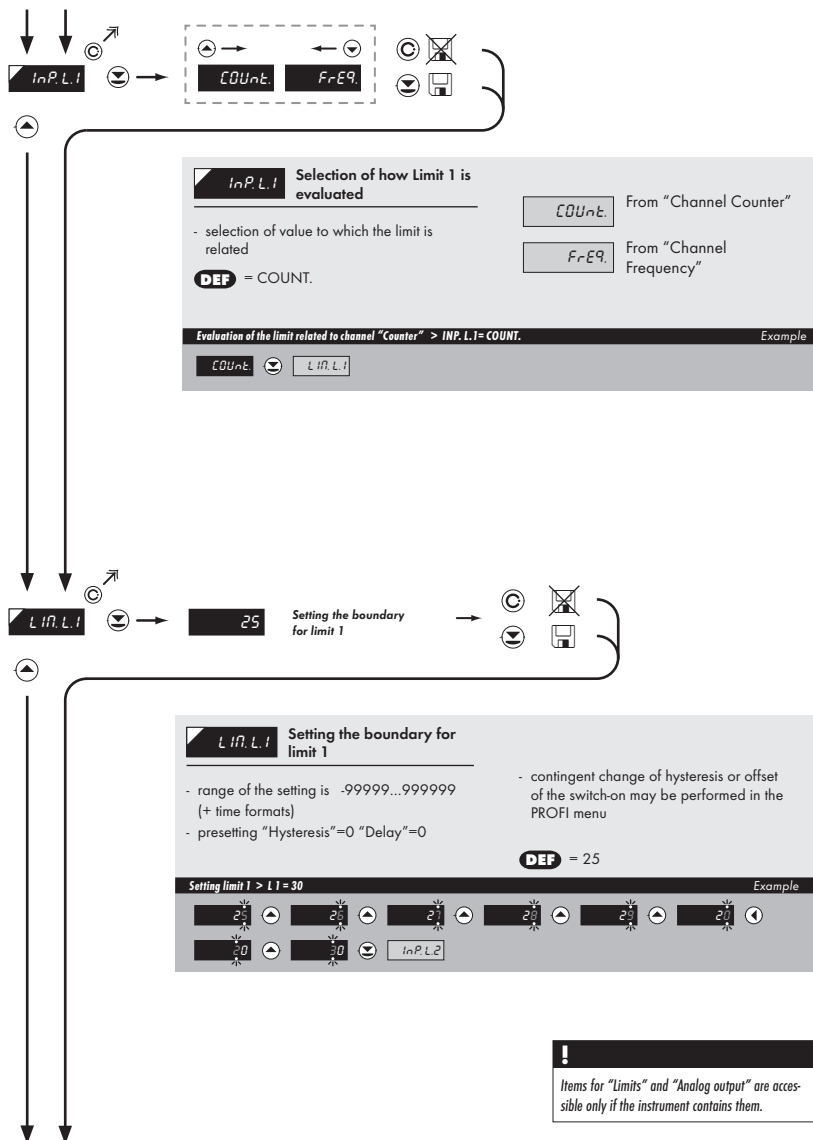





**InP.L.2** Selection of how Limit 2 is evaluated

- selection of value to which the limit is related

**DEF** = COUNT.

Evaluation of the limit related to channel "Counter" > INP.L.2= COUNT. Example

COUnL From "Channel Counter"

FrEQ From "Channel Frequency"

COUnL L1N.L.2

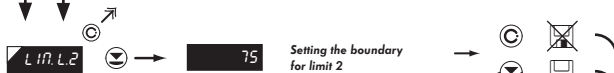

**L1N.L.2** Setting the boundary for limit 2

- range of the setting is -99999...999999 (+ time formats)
- presetting "Hysteresis"=0 "Delay"=0

- contingent change of hysteresis or offset of the switch-on may be performed in the PROFIL menu

**DEF** = 75

Setting limit 2 > L2 = 30 Example

10 10 10 10 10 30

30 DEF

\* following item of the menu depends on instrument equipment, provided it has an analog output the following item is „Type“

**InP.A.O.** Selection of how analogue output is evaluated

- selection of value to which the analogue output is related

**DEF** = COUNT.

From "Channel Counter" (COUNT)

From "Channel Frequency" (FrEq)

**Example**  
Evaluation of analogue output from channel "Counter" > INP.A.O. = COUNT.  
COUNT

**tYP.A.O.** Setting the type of analog output

**DEF** = E 4

Menu	Range	Description
0-20nA	0...20 mA	
Er 4-20	4...20 mA	with indication of error statement (<3,6 mA)
4-20nA	4...20 mA	
0-5nA	0...5 mA	
0-2 u	0...2 V	
0-5 u	0...5 V	
0-10 V	0...10 V	
+10 u	±10 V	

**Example**  
Type of analog output-0...10 V > tYP.A.O. = U 10  
4-20nA 0-5nA 0-2 u 0-5 u 0-10 u tIn.RD

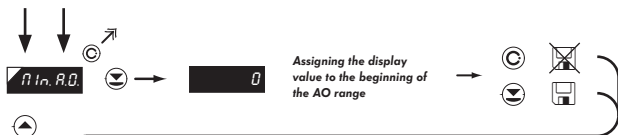

**Min. R.O.** Assigning the display value to the beginning of the AO range **DEF = 0**

- range of the setting is -99999...999999

**Display value for the beginning of the AO range > Min.A.O. = 0** *Example*

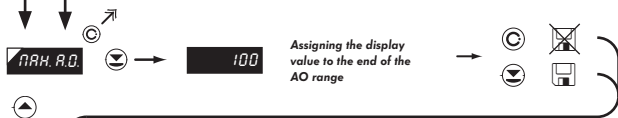

**Max. R.O.** Assigning the display value to the end of the AO range **DEF = 100**

- range of the setting is -99999...999999

**Display value for the end of the AO range > MAX. A.O. = 120** *Příklad*

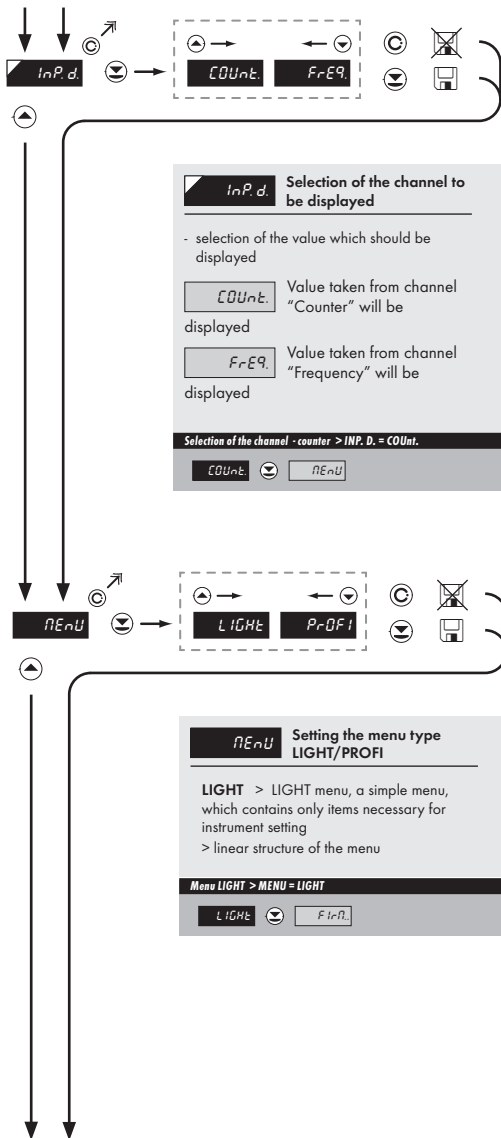

**InP.d.** Selection of the channel to be displayed

- selection of the value which should be displayed

**COUNT.** Value taken from channel "Counter" will be displayed

**FrEQ.** Value taken from channel "Frequency" will be displayed

**DEF** = COUNT.

**Selection of the channel - counter > INP. D. = COUNT.** Example

**COUNT** **MENU**

**MENU** Setting the menu type LIGHT/PROFI

**LIGHT** > LIGHT menu, a simple menu, which contains only items necessary for instrument setting  
> linear structure of the menu

**PROFI** > PROFI menu, a complete menu for entire instrument setting  
> tree structure of the menu

**DEF** = LIGHT

**Menu LIGHT > MENU = LIGHT** Example

**LIGHT** **PROFI**



**FIRM** Restoration of the instrument manufacture setting

- in case of incorrect setting or calibration it

is possible to return to manufacture setting. Prior execution of the changes you will be asked to confirm your selection (YES)

- reading the manufacture calibration and original setting of items in the menu

Restoration of manufacture setting > FIRM. Example

FIRM (up) YES (down) USER



**USER** Restoration of the instrument user setting

- downloading user setting of the instrument, i.e. setting which was stored under item SERVIC./RESTOR./SAVE

Restoration of user setting > USER Example

FIRM (up) YES (down) PPS.L1

**!**  
Do not perform restoration of user setting (USER) prior to its saving in Profi menu



**PAS.LI. Setting new access password**

- access password for LIGHT menu
- range of the numeral code 0...9999
- when setting password to "0000" the

access into LIGHT menu is accessible without call for entering it

- in case of loss of password universal password "8177" may be used

**DEF** = 0

**New password - 341 > PAS.LI. = 341** Example

0	1	2	3	4	5	6	7	8	9	Light
4	1	4	1	4	1	4	1	4	1	Light

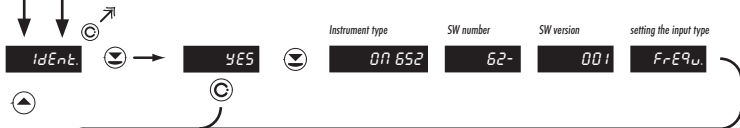

**IdEnt. SW version of the instrument**

- the display shows the type identification of the instrument, SW number, SW version and current input setting (Mode)

- if the SW version reads a letter on the first position, then it is a customer SW
- after the identification is completed the menu automatically quits the display and measuring mode is restored

1428 **Return to measuring mode**



## 6.0

## Setting "PROFI"

## PROFI

## Complete programming menu

- contains complete instrument menu and is protected by optional number code
- designed for expert users
- preset from manufacture is menu **LIGHT**

SETTING  
PROFI

- For expert users
- Complete instrument menu
- Access is password protected
- Possibility to arrange items of the „User“ menu
- Tree menu structure

## Switching over to "PROFI" menu



- temporary switch-over to **PROFI** menu, which is suitable to edit a few items
- after quitting **PROFI** menu the instrument automatically switches to **LIGHT** menu
- access is password protected (if it was not set under item N. PASS. =0)



- access into **LIGHT** menu and transition to item „MENU“ with subsequent selection of „PROFI“ and confirmation
- after re-entering the menu the **PROFI** type is active
- access is password protected (if it was not set under item N. PASS. =0)





## 6.1 Setting "PROFI" - INPUT

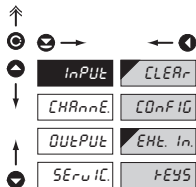

The basic instrument parameters are set in this menu

<b>CLEAR</b>	Resetting internal values
CONF IG	Primary instrument setting
<b>EHt. In</b>	Setting the external input function
FEYS	Setting the ENTER key function

## 6.1.1 Resetting internal values

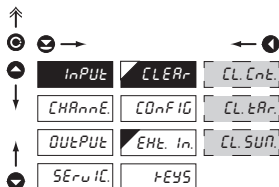
**CLEAR** Resetting internal values

**CL Cnt** Counter resetting

- when zeroed, the figure on the display will be added to the total sum („grand total“), a value which is stored in the instrument's internal memory.

**CL tAr** Tare resetting

**CL SUM** Zeroing of the sum

- summation is used for cumulated values (i.e. factory shifts) when values from individual shifts are added to the total sum.

#### 6.1.2 Instrument configuration

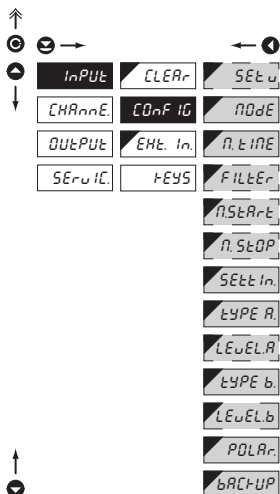

#### CONF IG Primary instrument setting

- SET u. Setting the initial value
- MODE Setting the instrument measuring mode
- BASE Setting the time base
- FILTER Setting the input filtration constant
- ASST Setting the stopwatch control
- ASST Setting stopwatch resetting
- SETT In. Automatic setting of the inputs
- TYPE - Setting the type of input
- LEVEL - Setting the input level
- POLAR Selection of active level/edge
- BACKUP Setting data backup/time

#### 6.1.2a Setting the initial value

C H

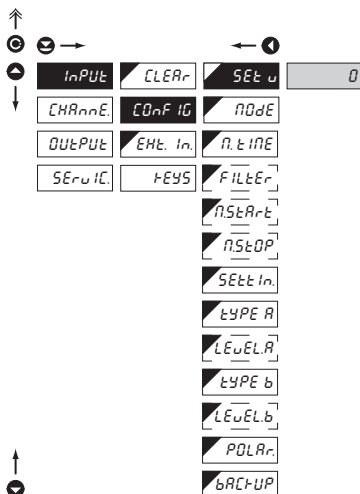

#### SET u. Setting initial value

- function allows the user a one-time setting of the display initial value

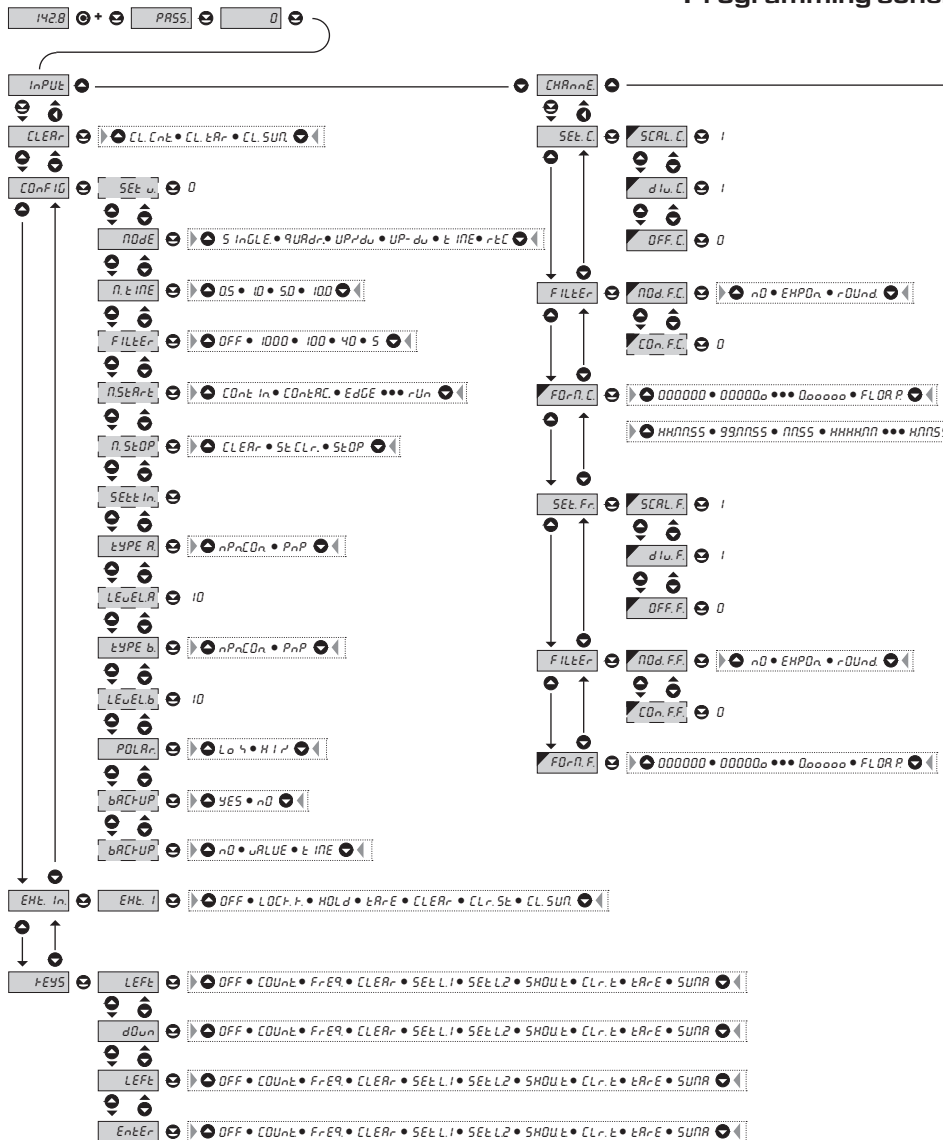

### me of PROFi MENU

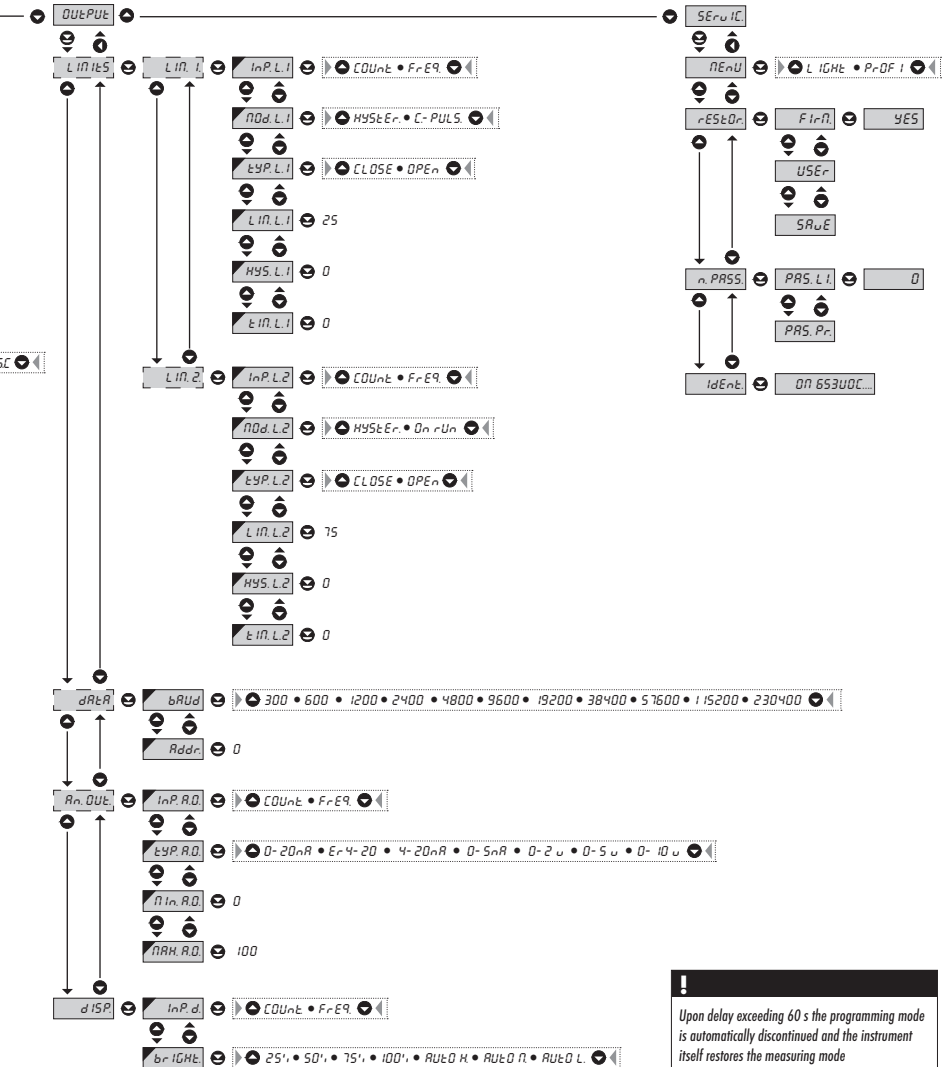

**!**  
 Upon delay exceeding 60 s the programming mode is automatically discontinued and the instrument itself restores the measuring mode

**6.1.2b Selection of measuring mode**

↑

INPUT	CLEAR	SEt.u.	SInGLE
CHARnE	COnt IG	NOdE	QUAdr
OUTPUT	EHt.In	n.tInE	UP-dw
SERuIC	KEYS	FILtEr	UP-dw
		nStArE	tInE
		nStOP	rEtC
		SEtE In	
		tYPE A	
		LEuEL A	
		tYPE b	
		LEuEL b	
		POLAR	
		bRtC-UP	

**NOdE Selection of instrument measuring mode**

- SInGLE** Impulse counter/  
Frequency measurement
- QUAdr** Impulse counter/  
Frequency measurement  
for IRC encoders
- measurement on two inputs (A&B). Can display count and frequency
  - in this mode every single rising edge of signal A and B is included in the count
- UP-dw** UP/DW Impulse counter/Frequency meter
- measurement on input A, (inp. B/direction). Can display count and frequency
- UP-dw** UP-DW Impulse counter/  
Frequency meter
- measures on inputs A (UP), B (DW). Can display count and frequency
- tInE** Mode „Stopwatch/  
timer“
- rEtC** Mode „Stopwatch/  
timer“ with RTC backup
- not in standard equipment

**6.1.2c Selection of measuring period/time base**

↑

INPUT	CLEAR	SEt.u.	0.5
CHARnE	COnt IG	NOdE	1.0
OUTPUT	EHt.In	n.tInE	5.0
SERuIC	KEYS	FILtEr	10.0
		nStArE	
		nStOP	
		SEtE In	
		tYPE A	
		LEuEL A	
		tYPE b	
		LEuEL b	
		POLAR	
		bRtC-UP	

**n.tInE Selection of measuring period/time base**

- if you set measuring period e.g. for 1 s, the measuring runs approximately from 1 s to 2 s (1 s + maximum one cycle of measured signal). If no signal arrives within 2 s it is taken that the signal has zero frequency
- range of setting of the time base is 0,5 s to 10 s
- in the „RTC“ regime with data projection the set time defines the cycle of switching between time/date, min. is 5 s, datum is displayed for approx. 2,5 s

#### 6.1.2.d Selection of input filter parameters

C H

↑  
⊙ ☺ → ← ⓪  
▲  
▼

INPUT	CLEAR	SEt u.	OFF
CHARnE	COnt IG	ADdE	1000
OUtPUt	EHt. In.	n. t. InE	100
SErviC.	KEYS	<b>FILtEr</b>	40
		n.StArE	5
		n.StOP	
		SEtE In.	
		tYPE A	
		LEuEL A	
		tYPE b	
		LEuEL b	
		POLAR.	
		bACTUP	

**DEF**

#### FILtEr Selection of digital input filter

- digital filter may suppress unwanted interfering impulses (e.g. relay backswings) on the input signal. The set parameter gives maximum possible frequency (Hz) of the instrument, which the instrument w/o limitation
- for pulse duty cycle of 50% - equal duration of Hi and Lo level\*
- **in case if interference the use of input filter is recommended**



*When accessing upon contact and available maximum input frequency we recommend using filter*

## 6.1.2e Selection of stopwatch/timer control

H

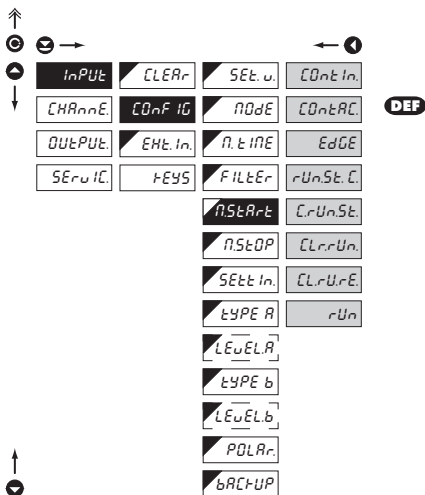
**n.StArE** Selection of stopwatch/timer control

- time setting menu is accessible only in the stopwatch/timer regime

**COnt.in** Stopwatch/timer is running constantly if the instrument is turned on

**COntAR** Stopwatch/timer is running upon contact making

**EdGE** Stopwatch/timer is controlled by the priming signal edge

- time is set off by the edge (by the signal passing across the comparing level) and stopped by the next edge

**rUn.St.C** Stopwatch/timer is controlled and reset by the edge of the priming signal

- time is set off by the edge (by the signal passing across the comparing level) and stopped by the next edge

**CrUnSt.** Stopwatch/timer is controlled and reset by the edge of the priming signal

- time is set off by the edge (by the signal passing across the comparing level) and stopped by the next edge

**CLr.rUn** Stopwatch/timer is reset and set off by the edge of the priming signal (when the time is not running)

**CLr.UrE** Stopwatch/timer is reset and set off by the edge of the priming signal, the cycle is repeated with every other edge

- regardless of whether the time is running or not

**rUn** Stopwatch/timer is only set off by the edge

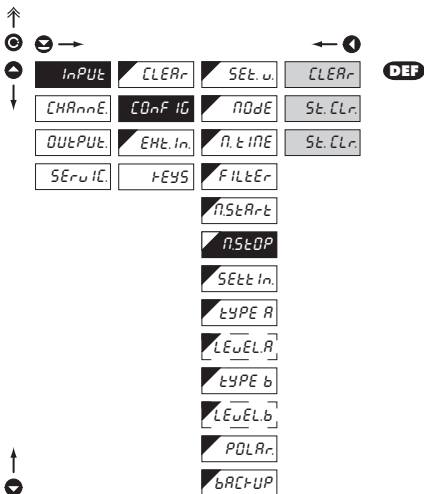

#### 6.1.2f Selection of stopwatch/timer resetting

H

#### n.STOP Selection of stopwatch resetting

- menu of the resetting option is accessible only in the stopwatch/timer regime

- CLEAR Stopwatch/timer is reset through input „Clear”
- St.CLr Stopwatch/timer is stopped and reset through input „Clear”
- StOP Stopwatch/timer is stopped through input „Clear”

#### 6.1.2g Automatic setting of the inputs

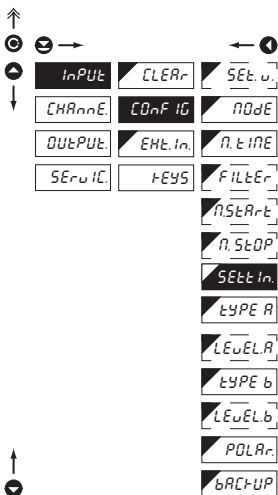

#### SEtE In. Automatic setting of the inputs

- it is possible to choose in the menu between automatic or manual setting for input A and B  
 - for automatic detection the minimum frequency required is 10 Hz

- ⬇ start of automatic input setting
- ⬇ manual input setting - down
- ⬆ manual input setting - up
- ⬆ confirm the setting and proceed to second input (short key stroke) to copy the setting of Input A to Input B (long key stroke)

**DEF** = NPN.CON.

## 6.1.2h Selection of the type of input

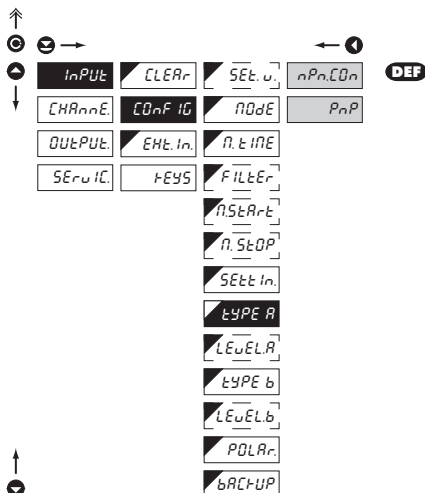
**TYPE A** Selection of type of input

- setting applies for Input A

nPn.CO Type of input NPN and upon contact

PnP Type of input PNP

**!**  
Input levels (Level A) must be set after this selection

**!**  
Setting for input Resetting (Level. B) is identical with setting for Input A

## 6.1.2i Setting input level

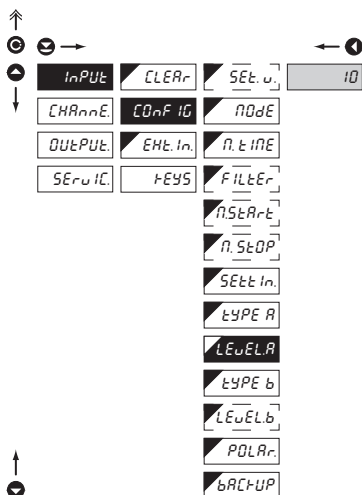
**LEVEL A** Setting input level

- setting applies for Input A
- setting level (only for type PNP) of the input voltage, the instrument subsequently automatically selects divider and thus comparing levels
- range of setting 0...43 V (Input A < 30 V, bracket No. 12) (Input B < 30 V, bracket No. 13)
- range of setting 43...300 V (Input A < 300 V, bracket No. 17) (Input B < 300 V, bracket No. 15)
- table of comparing levels is on page 8

**!**  
Setting for input Resetting (TYPE B) is identical with setting for Input A

#### 6.1.2j Selection of active level or edge

↑

⊙ →

↑

↓

INPUT CLEAR SET u. Lo **DEF**

CHARACT. CONF. ID ADDR Hi r

OUTPUT EHE. In. N. TIME

SERIAL KEYS FILTER

RESTORE

RESTOP

SETE In.

TYPE A

LEVEL A

TYPE b

LEVEL b

POLAR

BACKUP

↑

⊙

#### **POLAR** Selection of active level or edge

**Lo** Active upon change of declining edge Lo > Hi  
- upon entering the contact > active on switch-on

**Hi** Active upon change of entering edge Hi > Lo  
- upon entering the contact > active on switch-off

#### 6.1.2k Selection of display status backup

↑

⊙ →

↑

↓

INPUT CLEAR SET u. n0 **DEF**

CHARACT. CONF. ID ADDR YES

OUTPUT EHE. In. N. TIME

SERIAL KEYS FILTER

SETE In.

TYPE A

LEVEL A

TYPE b

LEVEL b

POLAR

BACKUP

↑

⊙

#### **BACKUP** Selection of display status backup

- setting display value restoration after power failure or instrument switch-off

**n0** After switch-on the instrument loads the display status from the memory

**YES** Instrument resets itself after switch-on

## 6.1.2h Setting the display status backup

H

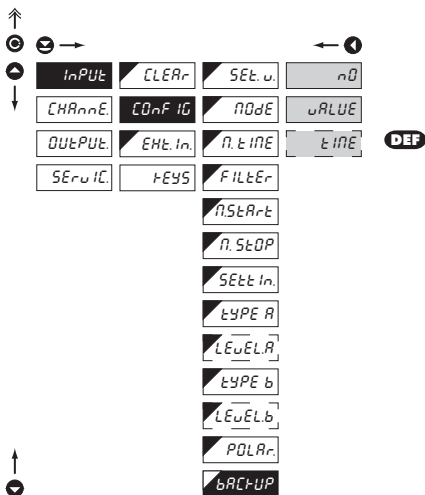
**bACkUP** Selection of display status backup

- time setting menu is accessible only in the stopwatch/timer regime
- setting display value restoration after power failure or instrument switch-off

nD Instrument resets itself after every switch-on

uALUE After switch-on the instrument loads the display status from the memory

t INE Instrument downloads „running“ time from RTC

- item accessible only with extension „Time backup“

#### 6.1.3 External input function selection

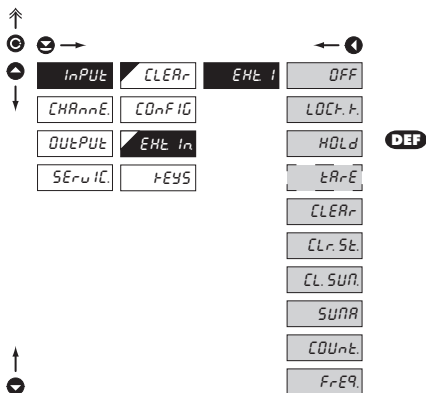

**!**  
Response time to the change of input is approx  
100 ms

#### EXT. In External input function selection

- OFF** Input is off
- LOCK F.** Auxiliary input governs the „LOCK“ function
  - the input governs the blocking of control keys on front panel
- HOLD** Auxiliary input governs the „HOLD“ function
  - the input governs the HOLD function, which blocks all instrument functions
- TARE** Auxiliary input governs the „TARE“ function
  - the TARE function is activated through the input, only in the “Frequency” mode
- CLEAR** Auxiliary input governs the „Clear“ function
  - stopwatch/counter is cleared (preset) through the input
- CLr. SE.** Auxiliary input governs the „Clear“ function
  - stopwatch/counter is cleared (preset) through the input, Stopwatch stops altogether
- CL. SUM.** Auxiliary input governs the „Clear Sum“ function
  - the “grand total” of the counter is zeroed
- SUM** Auxiliary input governs the „SUM“ function
  - the cumulated value is displayed
- COUnT.** Auxiliary input governs the counter display
  - the value of “Counter” channel is displayed
- FREQ.** Auxiliary input governs the frequency display
  - the value of “Frequency” channel is displayed

### 6.1.4 Optional accessory functions of the keys

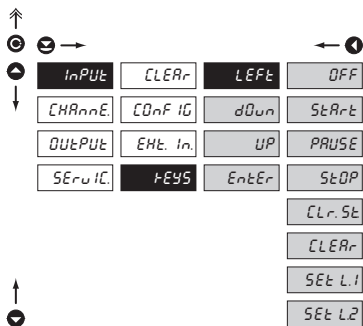
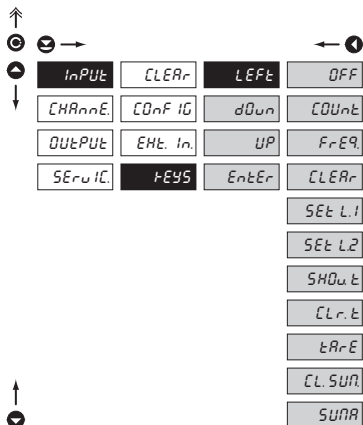

#### FEYS Assigning accessory functions of control keys

- this setting is identical for all control keys

OFF	Accessory functions are off
COUNT	Displays value from channel "Counter"
FREQ	Displays value from channel "Frequency"
CLEAR	Clears Counter
SET L-	Setting limit L1, resp. L2
SHOW T	Shows TARE
CLR T	Clears TARE
TARE	Activates function TARE
CL SUM	Clears the total sum
SUM	Displays the total sum (grand total)

#### FEYS Assigning accessory functions of control keys

- can be used only in mode "TIME" and "RTC"

- this setting is identical for all control keys

OFF	Accessory functions are off
START	Start - stopwatch/clock
PAUSE	Pause - stopwatch/clock
STOP	Stop - stopwatch/clock
CLR SE	Stop and clear - stopwatch/clock
CLEAR	Clear - stopwatch/clock
SET L-	Setting limit L1, resp. L2



## 6.2 Setting "PROFI" - CHANNEL

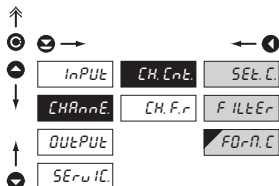

In this menu the instrument input parameters are set

- SEt.C. Setting calibration constant
- FIlLEr Setting the digital filters
- FbD-n.C Selection of projection format

### 6.2.1a Setting multiplying constant - Channel Counter

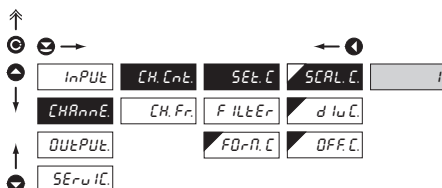

#### SCAL.C. Setting multiplying constant - channel C

- multiplying constant serves for calculation of input value to required display value
- by entering minus value the direction of calculation is changed, i.e. we count down
- range: -0,00001...999999
- **DEF** = 1

**!** **H**  
If non-zero value is set in the "TIME" or "RtC" mode in the "OFFSEt" item, it applies that the multiplying constant "SCALE" is negative

### 6.2.1b Setting division constant - Channel Counter

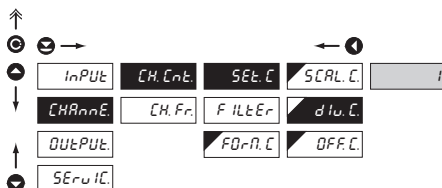

#### dIu.C. Setting division constant - channel C

- division constant serves for calculation of input value to required display value
- range: 0,00001...999999
- **DEF** = 1



#### 6.2.1c Setting additive constant - PRESET, Channel Counter

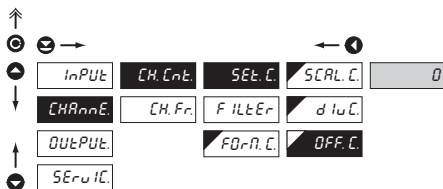

#### OFF.C. Setting PRESET constant - channel C

- offset of the measuring by a set value, which shall be loaded always upon instrument resetting
- range: -99999...999999

**DEF** = 0

**!** **H**  
If non-zero value is set in the "TIME" or "RTC" mode in the "OFF. C." item, it applies that the multiplying constant "SCAL. C." is negative

#### 6.2.2 Setting the digital filters - Channel Counter

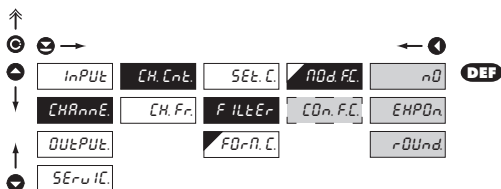

#### FIlTEr Setting the digital filters

##### COn.C. Setting the constant

- this menu item is always displayed after selection of a particular type of filter

**DEF** = 2

nD Filters are switched off

EHPDn Selection of exponential filter

- calculation of value from the number of measurements selected in „CON. C.“

rQUnd Selection of value round-up

- it is set by ...arbitrary number, which determines the projection step (e.g.: "Con. F.C."=2,5 > display 0, 2,5, 5,...)

**!**  
Identical setting is used for CH. Fr.

**6.2.3 Selection of projection format - Channel Counter**

inPUt	CH. EnE	SEt. C.	000000	<b>DEF</b>
CHAnnE	CH. Fr.	F. ILtEr	000000	
DUtPUt	FD-rn.C		000000	
SErvIC.			000.000	
			00.0000	
			0.00000	
			FLOR. P.	
			HH.nnnSS	<b>DEF</b> <b>H</b>
			99.nnnSS	
			HH.nnn	
			HHHH.nnn	
			nnnnSS	
			nnSS.CC	
			99SS.CC	
			H.nnnSS.C	

**FD-rn.C Selection of projection format**

- the instrument enables projection of number with decade positioning of decimal point
- for projection of time there are also other projection forms available

**!** **H**

*In mode "TIME" or "RTC" the time base is preset according to projection format*

*in seconds > 000000...0.00000, Floa.P., HH.MM.SS, 99.MM.SS, MMMM.SS*

*in minutes > HH.MM, HHHH.MM*

*in tenths of seconds > H.MM.SS.C*

*in hundredths of seconds > MM.SS.CC, 99.SS.CC*



*Identical setting is used for CH. Fr.*



### 6.3 Setting „PROFI“ - OUTPUTS

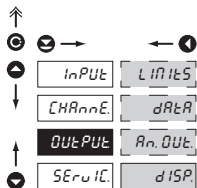

It is possible to set the parameters of the instrument output signals in this menu

**L iN tES** Setting the type and the switching of limits

**dRtR** Setting the type and the parameters of data output

**An. OUt** Setting the type and parameters of analog output

**dISP** Setting the display brightness

#### 6.3.1a Selection of how Limit 1 is evaluated

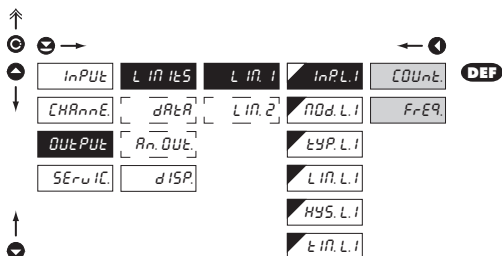

**inPL 1** Selection of how Limit 1 is evaluated

- selection of value to which the limit is related

**COUnT** From "Channel Counter"

**FrEQ** From "Channel Frequency"

#### 6.3.1b Selection of mode of output L 1

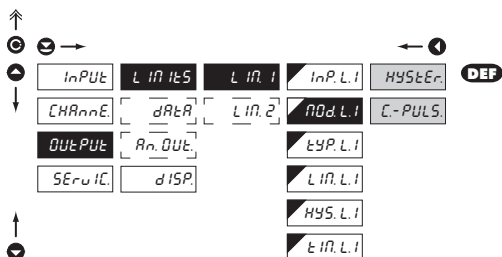

**nOd.L 1** Mode of limit 1

**HYS tEr** Standard mode - limit, hysteresis and delay

**C.-PULS** Automatic clearing of counter to preset value and generate an impulse of the length set in "TIM.L1"

**!** Setting is available only for LIM 1



## 6.3.1d Selection of type of output

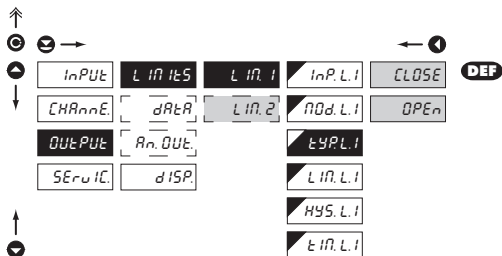

**εYP.L.1** Setting the type of relay function

**CLOSE** Relay switches on when the condition is met

**OPEN** Relay switches off when the condition is met

Setting is identical for LIM 1 and LIM 2

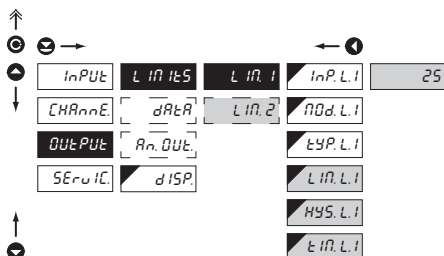
## 6.3.1e Setting values for limits evaluation

**LIM.L.1** Setting the boundary for relay switch-on

- within the full display range

**HYS.L.1** Setting hysteresis

- defines the band around the limit (on both sides, LIM.  $\pm 1/2$  HYS.)
- within the full display range

**t.M.L.1** Setting the offset of the relay switch-on

- setting within the range:  $\pm 0 \dots 99,9$  s
- positive time > relay switches on after crossing the limit (LIM. L1) and the set time (TIM. L1)
- negative time > relay switches off after crossing the limit (LIM. L1) and the set negative time (TIM. L1)

Setting is identical for LIM 1 and LIM 2

#### 6.3.2a Selection of transmission rate of data output

↑

⊙ →

↑

↓

INPUT LIMITS **bAUD** 600

CHARACT. dRtA Addr. 600

OUTPUT An. OUT. 1200

SERVIC. dISP. 2400

4800

9600 **DEF**

19200

38400

57600

115200

230400

↑

⊙

**bAUD** Setting the data output rate

---

300 Rate - 300 Baud

600 Rate - 600 Baud

1200 Rate - 1 200 Baud

2400 Rate - 2 400 Baud

4800 Rate - 4 800 Baud

9600 Rate - 9 600 Baud

19200 Rate - 19 200 Baud

38400 Rate - 38 400 Baud

57600 Rate - 57 600 Baud

115200 Rate - 115 200 Baud

230400 Rate - 230 400 Baud

#### 6.3.2b Setting the instrument address

↑

⊙ →

↑

↓

INPUT LIMITS **bAUD** 00

CHARACT. dRtA Addr. 00

OUTPUT An. OUT. Addr. Pb.

SERVIC. dISP.

↑

⊙

**Addr.** Setting the instrument address

---

- setting within the range 0...31
- **DEF** = 00

**6.3.3a Selection of how analogue output is evaluated**

↑  
 Ⓞ ☹ →  
 ▲  
 ↓  
 ↑  
 ▼

INPUT	LIMITS	INP.A.D.	COUNT	DEF
CHANNEL	DATA	TYPE.A.D.	FREQ.	
OUTPUT	AN.OUTPUT	AIN.A.D.		
SERVICES	DISP.	ARM.A.D.		

**INP.A.D.** Selection of how analogue output is evaluated

- selection of value to which the analogue output is related

- COUNT From "Channel Counter"  
 FREQ. From "Channel Frequency"

**6.3.3b Selection of type of analog output**

↑  
 Ⓞ ☹ →  
 ▲  
 ↓  
 ↑  
 ▼

INPUT	LIMITS	INP.A.D.	0-20mA	DEF
CHANNEL	DATA	TYPE.A.D.	Er4-20	
OUTPUT	AN.OUTPUT	AIN.A.D.	4-20mA	
SERVICES	DISP.	ARM.A.D.	0-5mA	

0-2 V  
 0-5 V  
 0-10 V  
 ±10 V

**TYPE.A.D.** Setting the type of analog output

- 0-20mA Type 0...20 mA  
 Er4-20 Type 4...20 mA  
 - with indication of error statement (<3,6 mA)  
 4-20mA Type 4...20 mA  
 0-5mA Type 0...5 mA  
 0-2 V Type 0...2 V  
 0-5 V Type 0...5 V  
 0-10 V Type 0...10 V  
 ±10 V Type ±10 V



#### 6.3.3b Selection of analog output range

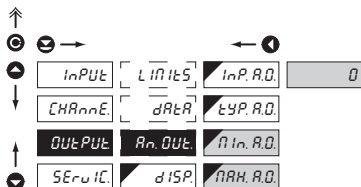

#### An. OUT. Setting the analog output range

- analog output is isolated and its value corresponds with the displayed data. It is fully programmable, i.e. it allows to assign the AO limit points to any two arbitrary points of the entire measuring range

**nIn. R.D.** Assigning the displayed value to the beginning of the analog output range

- range of the setting is -99999...999999

- **DEF** = 0

**nRH. R.D.** Assigning the displayed value to the end of the analog output range

- range of the setting is -99999...999999

- **DEF** = 100

#### 6.3.4a Selection of the channel to be displayed

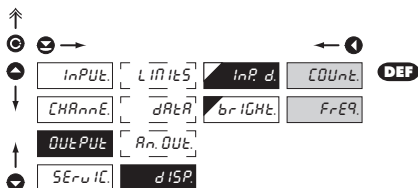

#### InP. d. Selection of the channel to be displayed

- selection of the value which should be displayed

**COUnT.** Value taken from channel "Counter" will be displayed

**FrEQ.** Value taken from channel "Frequency" will be displayed

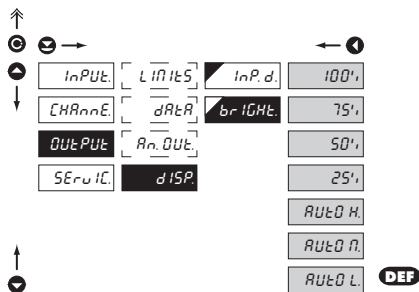
**6.3.4b Selection of display brightness**

**brIGHt Setting the display brightness**

- by selecting the display brightness we may react properly to light conditions in place of location of the instrument

25%	Display brightness - 25%
50%	Display brightness - 50%
75%	Display brightness - 75%
100%	Display brightness - 100%
AUTO H	Automatic brightness adjustment - High
AUTO M	Automatic brightness adjustment - Medium
AUTO L	Automatic brightness adjustment - Low

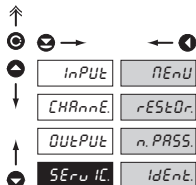

## 6.4 Setting "PROFI" - SERVICE



The instrument's service functions are set in this menu

nEnU	Selection of menu type LIGHT/PROFI
rEStOr.	Restoration of the manufacture setting and instrument calibration
n.PASS	Setting new access password
IdEnt	Instrument identification

## 6.4.1 Selection of the type of programming menu

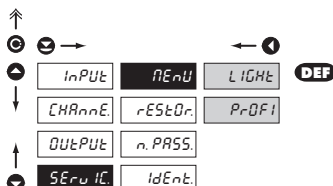

Change of setting is valid with next access into menu

**nEnU** Selection of menu type LIGHT/PROFI

- allows to set the menu complexity as per user needs and abilities

**LIGHT** Active LIGHT menu

- simple programming menu, contains only items necessary for instrument configuration and setting
- linear menu structure > items in succession

**PrDFI** Active PROF I menu

- complete programming menu for expert users
- tree menu

#### 6.4.2 Restoration of the manufacture setting

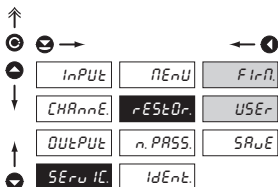

After restoration of setting the instrument switches off for several seconds

#### rESTOr. Restoration of the instrument manufacture setting

**FIrN.** Return to manufacture setting of the instrument

- downloading manufacture setting for currently selected type of instrument (items described DEF)

**USEr** Return to user setting of the instrument

- downloading user setting of the instrument, i.e. setting which was stored under item SERVIC./RESTOR./SAVE

**SRvE** Storing user setting of the instrument

- storing the setting enables the operator its future contingent restoration

#### 6.4.3 Setting new access password

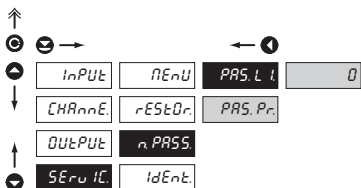

#### n.PASS. Setting new password for access into the LIGHT and PROFI menu

- this option allows to change the numeric code, which blocks the access into LIGHT and PROFI Menu.
- numeric code range: 0...9999
- universal passwords in the event of loss: LIGHT Menu > „8177“  
PROFI Menu > „7915“

#### 6.4.4 Instrument identification

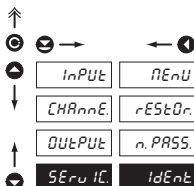

#### IdEnt. Projection of instrument SW version

- the display shows the type identification of the instrument, SW number, SW version and current input setting (Mode)
- if the SW version reads a letter on the first position, then it is a customer SW

## 7.0 "USER" menu configuration

- **USER** menu is designed for users who need to change only several items of the setting without the option to change the basic instrument setting (e.g. repeated change of limit setting)
- there are no default items from manufacture in **USER** menu
- menu configuration possible on items indicated by inverse triangle 
- setting may be performed in **LIGHT** or **PROFI** menu, with the **USER** menu then overtaking the given menu structure



- For user operation
- Menu items are set by the user (Profi/Light) as per request
- Access is not password protected

## SETTING

flashing sign - current setting is displayed



**n0**

item will not be displayed in USER menu

**YES**

item will be displayed in USER menu with the chance of editing

**SH0**

item will be solely displayed in USER menu

### Setting sequence of items in "USER" menu

In compiling USER menu from active LIGHT menu the items (max. 10) may be assigned a sequence, in which they will be projected in the menu

setting projection sequence



#### Example:

Into USER menu were selected these items:

(keys + ) > CL. Cnt., LIM. L 1, LIM. L 2, for which we have preset this sequence:

(tlačítky + ):

CL. Cnt.	5
LIM. L 1	0 (sequence not determined)
LIM. L 2	1

Upon entering USER menu

(key ) items will be projected in the following sequence: LIM. L 2 > CL. Cnt. > LIM. L 1

The instruments communicate via serial line RS232 or RS485. For communication they use the ASCII protocol. Communication runs in the following format:

ASCII: 8 bit, no parity, one stop bit

The transfer rate is adjustable in the instrument menu and depends on the control processor used. The instrument address is set in the instrument menu in the range of 0 + 31. The manufacture setting always presets the ASCII protocol, rate of 9600 Baud, address 00. The type of line used - RS232 / RS485 - is determined by an exchangeable card automatically identified by the instrument.

## COMMANDS FOR INSTRUMENT OPERATION

Individual commands are described in freely downloadable SW called OM Link and also in a description when you can find at [www.orbit.merret.cz/rs](http://www.orbit.merret.cz/rs).

A command consists of a number and a letter. The size of the letters have a significance.

## DETAILED DESCRIPTION OF COMMUNICATION VIA SERIAL LINE

Activity	Data transferred										
Data solicitation (PC)	#	A	A	<CR>							
Data transfer (Instrument)	>	R	<SP>	D	D	D	D	D	(D)	(D)	<CR>
Command confirmation (Instrument) - OK	!	A	A	<CR>							
Command confirmation (Instrument) - Bad	?	A	A	<CR>							
Instrument identification	#	A	A	1Y	<CR>						
HW identification	#	A	A	1Z	<CR>						
One-time measurement	#	A	A	7X	<CR>						
Repeated measurement	#	A	A	8X	<CR>						
Setting to transmit display + relay value	#	A	A	1X	<CR>						
Setting to transmit measured value	#	A	A	1x	<CR>						
Setting limit 1	#	A	A	1L	D	(D)	(D)	(D)	(D)	(D)	<CR>
Setting limit 2	#	A	A	2L	D	(D)	(D)	(D)	(D)	(D)	<CR>

## LEGENDA

#	35	23 <sub>H</sub>	Beginning of the command
A	A	0...31	Two signs of the inst. address (sending in ASCII - decades and units, ex. "01", "99" universal
<CR>	13	0D <sub>H</sub>	Carriage return
<SP>	32	20 <sub>H</sub>	Space
D			Data - usually signs "0"... "9", "...", "..."; (D) - DP and (-) may prolong data
R	50 <sub>H</sub> ...	57 <sub>H</sub>	Relay and Tare status
!	33	21 <sub>H</sub>	Positive command confirmation (ok)
?	63	3F <sub>H</sub>	Negative command confirmation (bad)
>	62	3E <sub>H</sub>	Beginning of the transmitted data

## RELAY, TARE

Signs	Relay 1	Relay 2	Tare
P	0	0	0
Q	1	0	0
R	0	1	0
S	1	1	0
T	0	0	1
U	1	0	1
V	0	1	1
W	1	1	1





ERROR	CAUSE	ELIMINATION
<i>E.d.U<sub>n</sub></i>	Number is too small (large negative) to be displayed	change DP setting, channel constant
<i>E.d.O<sub>n</sub></i>	Number is too large to be displayed	change DP setting, channel constant
<i>E.t.U<sub>n</sub></i>	Number is outside the table range	increase the table values, change input setting (channel constant)
<i>E.t.O<sub>n</sub></i>	Number is outside the table range	increase the table values, change input setting (channel constant)
<i>E.l.U<sub>n</sub></i>	Input quantity is smaller than permitted input quantity range	change input signal value or input (range) setting
<i>E.l.O<sub>n</sub></i>	Input quantity is larger than permitted input quantity range	change input signal value or input (range) setting
<i>E.H<sub>n</sub></i>	A part of the instrument does not work properly	send the instrument for repair
<i>E.EE</i>	Data in EEPROM corrupted	perform restoration of manufacture setting, upon repeated error statement send instrument for repair
<i>E.SEt</i>	Data in EEPROM outside the range	perform restoration of manufacture setting, upon repeated error statement send instrument for repair
<i>E.CLr</i>	Memory was empty (presetting carried out)	upon repeated error statement send instrument for repair, possible failure in calibration



**INPUT**

Type:	upon contact, TTL, NPN/PNP
Measuring:	1x counter/Frequency UP or DOWN 1x counter/Frequency UP/DOWN 1x counter/Frequency for IRC sensor 1x stopwatch/timer - measuring range isadjustable
Input frequency:	0,1...50 kHz (Mode SINGLE) 0,1...20 kHz (Mode UP/DW) 0,1...20 kHz (Mode UP-DW) 0,1...20 kHz (Mode QUADR. - Frequency) 0,1...10 kHz (Mode QUADR. - Counter) (for frequency duty cycle of 50 %)
Voltage levels	9,7 - 14,4 - 19,2 - 23,9 - 28,7 - 33,5 - 38,3 - 43,0 V 84 - 128 - 170 - 211 - 253 - 295 - 301 V

**PROJECTION**

Display:	999999, intensive red or green 7-segment LED, digit height 14 mm
Projection:	-99999...999999
Decimal point:	adjustable - in programming mode
Brightness:	adjustable - in programming mode

**INSTRUMENT ACCURACY**

Temperature coef.:	50 ppm/°C
Accuracy:	±0,02 % of the range + 1 digit (frequency)
Time base:	0,5/1/5/10 s
Multiplying constant:	±0,00001...999999
Division constant:	±0,00001...999999
Filtration constant:	allows for setting max. valid frequency, which is processed (OFF/S...1000 Hz)
Type of filter:	digital
Preset:	-99999...999999
Data backup:	preservation of measured data even after instrument switch-off (EEPROM)
Functions:	Tare - display resetting Summation - (grand total) registr of shifts Hold - stop measuring (upon contact) Lock - control keys locking
RTC:	the course of time is backed up by battery upon disconnection from the instrument supply (may be turned off - jumper inside the instrument) minimum lifetime 1 year
Battery:	Lithium cell CR 2032RV, 3V/220 mAh
OM Link:	Company communication interface for instrument operation, setting and update
Watch-dog:	reset after 540 ms
Calibration:	pri 25°C α 40 % t.v.

**COMPARATOR**

Type:	digital, adjustable in the menu, contact switch-on < 50 ms
Limits:	-99999...999999
Hysteresis:	0...999999
Delay:	0...99,9 s
Outputs:	2x relays with switch-on contact (Form A) (230 VAC/30 VDC, 3 A)*
Relay:	1/8 HP 277 VAC, 1/10 HP 125 V, Pilot Duty D300

**DATA OUTPUTS**

Protocols:	ASCII, Profibus
Data format:	8 bit + no parity + 1 stop bit
Rate:	600...230 400 Baud
RS 232:	isolated, two-way communication
RS 485:	isolated, two-way communication, addressing (max. 31 instruments)

**ANALOG OUTPUTS**

Type:	isolated, programmable with 12-bit D/A converter, type and range are selectable in programming mode
Non-linearity:	0,1 % of the range
TC:	15 ppm/°C
Rate:	response to change of value < 50 ms
Voltage:	0...2 V/5 V/10 V/±10 V
Current:	0...5/20 mA/4...20 mA - compensation of conduct up to 500 Ohm

**EXCITATION**

Adjustable:	5...24 VDC/max. 1,2 W, isolated
-------------	---------------------------------

**POWER SUPPLY**

Options:	10...30 V AC/DC, 10 VA, isolated, - fuse inside (T 4000 mA) 80...250 V AC/DC, 10 VA, isolated - fuse inside (T 630 mA)
----------	---

**MECHANIC PROPERTIES**

Material:	Noryl GFN2 SE1, incombustible UL 94 V-I
Dimensions:	96 x 48 x 120 mm
Panel cut-out:	90,5 x 45 mm

**OPERATING CONDITIONS**

Connection:	connector terminal board, conductor cross-section <1,5 mm <sup>2</sup> / <2,5 mm <sup>2</sup>
Stabilisation period:	within 15 minutes after switch-on
Working temp.:	-10°...60°C
Storage temp.:	-10°...85°C
Cover:	IP65 (front panel only)
Construction:	safety class I
Overvoltage category:	EN 61010-1, A2

\* values apply for resistance load

Izolační pevnost:	4 kVAC after 1 min between supply and input 4 kVAC after 1 min between supply and data/analog output 4 kVAC after 1 min between supply and relay output 2,5 kVAC after 1 min between input and data/analog output
Insulation resistance:	for pollution degree II, measurement category III Instrument power supply > 670 V (PI), 300 V (DI) Input/output > 300 V (PI), 150 V (DI)
EMC:	EN 61326-1

Front view

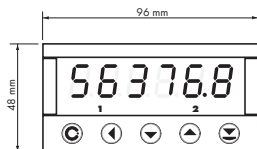

Panel cut

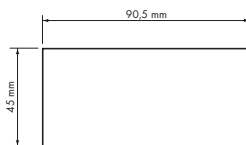

Side view

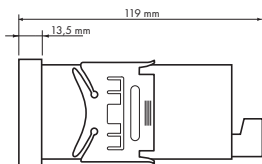

Panel thickness: 0,5...20 mm

### Instrument installation

1. insert the instrument into the panel cut-out
2. fit both travellers on the box
3. press the travellers close to the panel

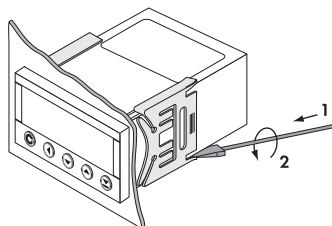
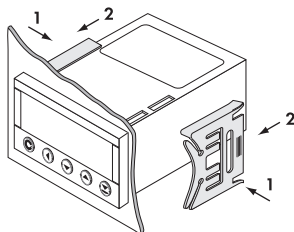

### Instrument disassembly

1. slide a screw driver under the traveller wing
2. turn the screw driver and remove the traveller
3. take the instrument out of the panel

Product **OM 653UQC**  
 Type .....  
 Manufacturing No. ....  
 Date of sale .....

**GUARANTEE**

A guarantee period of 60 months from the date of sale to the user applies to this instrument.  
 Defects occurring during this period due to manufacture error or due to material faults shall be eliminated free of charge.

For quality, function and construction of the instrument the guarantee shall apply provided that the instrument was connected and used in compliance with the instructions for use.

The guarantee shall not apply to defects caused by:

- mechanic damage
- transportation
- intervention of unqualified person incl. the user
- unavoidable event
- other unprofessional interventions

The manufacturer performs guarantee and post.guarantee repairs unless provided for otherwise.



**Y E A R S**

Stamp, signature

# ES DECLARATION OF CONFORMITY

**Company:** **ORBIT MERRET, spol. s r.o.**  
Klánska 81/141, 142 00 Prague 4, Czech Republic, IDNo: 00551309

**Manufactured:** **ORBIT MERRET, spol. s r.o.**  
Vodňanská 675/30, 198 00 Prague 9, Czech Republic

declares at its explicit responsibility that the product presented hereunder meets all technical requirements, is safe for use when utilised under the terms and conditions determined by ORBIT MERRET, spol.s r.o. and that our company has taken all measures to ensure conformity of all products of the types referred-to hereunder, which are being brought out to the market, with technical documentation and requirements of the appurtenant Czech statutory orders.

**Product:** Programmable panel instrument

**Type:** **OM 353/653**

**Version:** UNI, DC, AC, UQC

## It has been designed and manufactured in line with requirements of:

Statutory order no. 17/2003 Coll., on low-voltage electrical equipment (directive no. 73/23/EHS)  
Statutory order no. 616/2006 Coll., on electromagnetic compatibility (directive no. 2004/108/EC)

## The product qualities are in conformity with harmonized standard:

El. safety: EN 61010-1

EMC: EN 61326-1

Electrical measurement, EMC standards „Industrial use“

EN 50131-1, chap. 14 and chap. 15, EN 50130-4, chap. 7, EN 50130-4, chap. 8 (EN 61000-4-11, ed. 2), EN 50130-4, chap. 9 (EN 61000-4-2), EN 50130-4, chap. 10 (EN 61000-4-3, ed. 2), EN 50130-4, chap. 11 (EN 61000-4-6), EN 50130-4, chap. 12 (EN 61000-4-4, ed. 2), EN 50130-4, kap. 13 (EN 61000-4-5), EN 61000-4-8, EN 50130-5, chap. 20, prEN 50131-2-1, Cor. 9.93.1, EN 61000-4-9, EN 61000-6-1, EN 61000-3-2, EN 61000-3-3, EN 55022, chap. 5 and chap. 6

The product is furnished with CE label issued in 2010.

## As documentation serve the protocols of authorized and accredited organizations:

EMC MO ČR, Zkušebna tech. prostředků, protocol No.: 80/6-280/2007 of 13/11/2007  
MO ČR, Zkušebna tech. prostředků, protocol No.: 80/6-283/2007 of 26/10/2007

Place and date of issue: Prague, 1. March 2010

Miroslav Hackl  
Company representative

Assessment of conformity pursuant to §22 of Act no. 22/1997 Coll. and changes as amended by Act no.71/2000 Coll. and 205/2002 Coll