



OMB 301

PROGRAMMABLE BARGRAPH

DC VOLTMETER/AMMETER

PROCESS MONITOR

OHMMETER

THERMOMETER FOR PT 100

THERMOMETER FOR THERMOCOUPLES

INSTRUMENT FOR LINEAR POTENTIOMETERS

SAFETY INSTRUCTIONS

Please, read the enclosed safety instructions carefully and observe them! These instruments should be safeguarded by isolated or common fuses (breakers)! For safety information the EN 61 010-1 + A2 standard must be observed.

This instrument is not explosion-safe!

TECHNICAL DATA

Measuring instruments of the OMB 301 series conform to the European regulation 89/336/EWG and the Ordinance 168/1997 Coll.

They are up to the following European and Czech standards:

EN 55 022, class B

EN 61000-4-2, -4, -5, -6, -8, -9, -10, -11

The instruments are applicable for unlimited use in agricultural and industrial areas.

CONNECTION

Supply of energy from the main line has to be isolated from the measuring leads.



Grounding on terminal 3 has to be connected at all times



ORBIT MERRET, spol. s r.o.

Vodňanská 675/30

198 00 Praha 9

Czech Republik

Tel: +420 - 2 - 8104 0200

Fax: +420 - 2 - 8104 0299

e-mail: orbit@merret.cz

www.orbit.merret.cz

1. CONTENTS

1. Contents	3
2. Instrument description	4
3. Connection	6
4. Setting	8
4.1 Programming modes	9
4.1.1 Configuration mode	9
4.1.2 User mode	10
4.2 Setting the decimal point and the minus sign	10
4.3 Configuration mode	11
4.3.1 Entering the configuration mode	11
4.3.2 Configuration mode - MENU	11
4.3.2.1 Limits	12
4.3.2.2 Analogue output	12
4.3.2.3 Data output	12
4.3.2.4 Display brightness	13
4.3.2.5 Tare	13
4.3.3 Configuration mode - KONFIG	14
4.3.3.1 Limits	14
4.3.3.2 Analogue output	14
4.3.3.3 Data output	15
4.3.3.4 Display brightness	15
4.3.3.5 Tare	16
4.3.4 Configuration mode - INPUT	17
4.3.4.1 Display on the display unit (DC/AC/PM/DU)	17
4.3.4.2 Shifting the range offset and compensation of the conduct (RTD)	17
4.3.4.3 Setting the cold junction (T/C)	18
4.3.4.4 Digital filter	18
4.3.4.5 Type of input	19
4.3.4.6 Measuring rate	20
4.3.4.7 Displaying the measuring units	20
4.3.5 Configuration mode - BARGRAPH	20
4.3.5.1 Setting	21
4.3.5.2 Setting the bargraph projection mode	21
4.3.5.3 Setting the colours	21
5. Configuration of the input unit	22
Setting the shorting links	22
Setting the additional voltage	22
6. Error statements	23
7. Table of symbols	24
8. Methods of measuring of the cold junction	25
9. Communication protocol RS 232/485	26
10. Technical data	28
11. Instrument dimensions	30
12. Certificate of guarantee	31

2. INSTRUMENT DESCRIPTION

DESCRIPTION

The OMB 301 model is a panel tricolour bargraph with auxiliary 6-digit display, manufactured in the following alternatives:

DC	DC voltmeter/ampere meter
PM	Process monitor
DU	Display instrument for linear potentiometers
W	Wattmeter
OHM	Ohmmeter
RTD	Thermometer for sensors Pt 100
T/C	Thermometer for sensors J, K, T, E, B, S, R, N

The instruments are based on an 8-bit microcontroller with precise A/D converter, that secures high accuracy, stability and easy operation of the instrument.

The standard equipment of the instruments include programmable display of the display unit, selection of the measuring rate, digital filter on the input signal and tare.

The digital filter allows to set the range of the insensitiveness in which the displayed data does not change even if the input signal is changed.

OPERATION

The instrument is set and controlled by five control keys located on the front panel. All programmable settings of the instrument are realised in two modes:

The "configuration menu" (hereinafter referred to as "CM") is protected by an optional number code and contains a complete instrument setting.

The "user menu" (hereinafter referred to as "UM") may contain arbitrary programming settings allowed in "CM" with another selective restriction (see, change).

All programmable parameters are saved in the EEPROM memory (they hold even after the instrument is switched off).

The Hold function (stopping the measuring) is controlled via a contact with the connector.

The measured units may be projected on the display.

CALIBRATION

In CM - the configuration input - it is possible to set complete parameters of the input part (calibration, compensation, digital filter, measuring rate, measuring units, etc.).

By selecting the shorting links and the setting in CM it is possible to change the type and measuring range of the instrument. The particular description of calibration for individual types of instruments is on page 19.

EXTENSION

Additional voltage is suitable for feeding sensors (transmitters) and converters. It has a galvanic isolation and continuously adjustable value in the range of 2 - 24 VDC.

Comparators serve to monitor two limit values with relay output. Reaching the preset limits is signalled by LED and at the same time by the switch-on of the relevant relay.

Data outputs are for their rate and accuracy suitable for transmission of the measured data for further display or directly into the control systems. We offer an isolated RS 232 and RS 485 with the ASCII protocol.

Analogue outputs will find their place in applications where further evaluating or processing of measured data in external devices is required. We offer universal analogue output with the option of selection of the type of output - voltage/current. The value of analogue output corresponds with the displayed data and its range is selective in programming mode.

3. CONNECTION

The lead for feeding the instrument should not be in the proximity of the incoming low-potential signals.

Contactors, motors with larger input power and other efficient elements should not be in the proximity of the instrument.

The lead into the input of the instrument (the measured quantity) should be in sufficient distance from all power leads and appliances. Provided this cannot be secured it is necessary to use shielded leads with connection to ground.

The instruments are tested in compliance with standards for use in industrial area, yet we recommend to abide by the above mentioned principles.

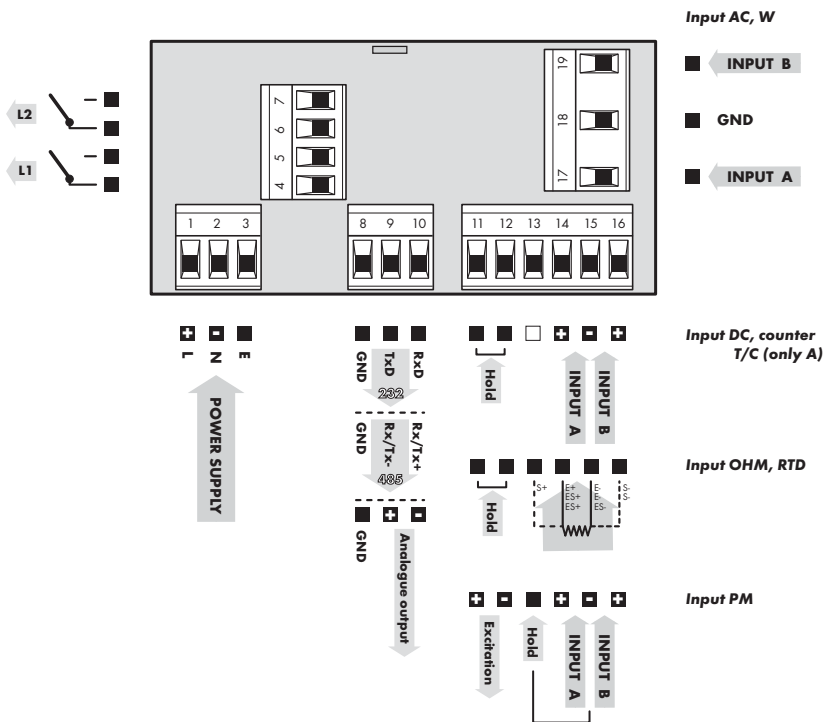





! For better accuracy of the measurement it is advisable - in case of 2- or 3- wire connection - to fix links to non-connected inputs of the OMB 301 - RTD.

4. INSTRUMENT SETTING

Access to programming steps depends on your order, i.e. on the overall equipment of the instrument. Setting and controlling the instrument is performed through 4 control keys on the front panel. By means of these controls it is possible to browse through the operating program and to select and set the required values.



Functions of the controls in the programming modes

				
measuring regime				
access into menu	Tare	Tare projection		
item browsing				
exit from menu	access to next level	back to previous level		shift to next item
editing - list				
cancel editing	confirm selected item	shift to higher level	browsing down	browsing up
editing - numbers				
cancel editing	confirm selected number	shift to higher decade	change of selected no.-down	change of selected no.- up
<i>Menu</i>	<i>Enter</i>	<i>Left</i>	<i>Down</i>	<i>Up</i>



In case of delay longer than 30 s the programming mode will be automatically discontinued and the instrument returns by itself into the measuring mode

4.1. PROGRAMMING MODES

4.1.1. Configuration mode

- complete instrument setting - designed for professional service and maintenance
- access is password blocked
- setting the authorization for „User Mode“

⊙ + ⊙ Access to the "Configuration mode"

NErU ⊙ L IN lTS ⊕ ANALOG (dAtA) ⊕ br IGht ⊕ CLr.tAr

- ⊕ ⊙ → L IN lTS Setting the limits, hysteresis and delay
- ↓ ⊙ → ANALOG Setting the analogue or data output
- ⊙ → dAtA Setting the analogue or data output
- ⊙ → br IGht Setting the display brightness
- ⊙ → CLr.tAr Tare resetting

NErU ⊙ COnt IN ⊕ COnt AV (COnt RS) ⊕ COnt br ⊕ COntAr

- ⊕ ⊙ → COnt IN Configuration of access into the „Limits“ menu and relay function
- ↓ ⊙ → COnt AV Config. of access into the „AV“ menu and selection of the AV type
- ⊙ → COnt RS Configuration of access into the „RS“ menu and selection of the RS type
- ⊙ → COnt br Configuration of access into the „Brightness“ menu
- ⊙ → COntAr Configuration of access into the „Tare“ menu

INPUt ⊙ n In ⊕ nAx ⊕ F ILtEr ⊕ tYPE ⊕ rERd ⊕ CHArS

- ⊕ ⊙ → n In Setting the projection of the display for minimum input signal
- ↓ ⊙ → nAx Setting the projection of the display for maximum input signal
- ⊙ → F ILtEr Setting the digital filter
- ⊙ → tYPE Setting the type of input
- ⊙ → rERd Setting the measuring rate
- ⊙ → CHArS Setting the projection of measuring units

bArGr. ⊙ n In ⊕ nAx ⊕ nOdE ⊕ bAr. Or. ⊕ bAr. 1r. ⊕ bAr. 2r.

- ⊕ ⊙ → n In Sets the display data, which corresponds with the bargraph minimum
- ↓ ⊙ → nAx Sets the display data, which corresponds with the bargraph maximum
- ⊙ → nOdE Setting the bargraph projection mode
- ⊙ → bAr. Or Setting the colours
- ⊙ → bAr. 1r Setting the colours
- ⊙ → bAr. 2r Setting the colours

4.1.2 User mode

- is designated for the operator of the instrument
- may contain setting the limits, analogue/data output and brightness with a restraint, which is adjustable in the "Configuration mode"



Access into the "User mode"

MENU (down arrow) LIMITS (up arrow) ANALOG (DATA) (up arrow) BRIGHT (up arrow) CLEAR

- (up arrow) (down arrow) → LIMITS Setting the limits, hysteresis and delay
- ↓ (down arrow) → ANALOG Setting the analogue output
- (down arrow) → DATA Setting the data output
- (down arrow) → BRIGHT Setting the display brightness
- (down arrow) → CLEAR Tare resetting



Setting is the same as in the Configuration mode, chapters 4.4.1.1 - 4

4.2 SETTING (.) AND (-)

The option of setting the decimal point and the minus sign depends on the type of instrument.

Decimal point

- in „CM“ - projection on the display - minimum **DC/AC/PM/DU/OHM**
- in other valid settings decimal point is displayed automatically
- limits, hysteresis, projection on the display - maximum, filter

Minus sign



- limits **DC/AC/PM/DU/RTD/OHM**
- analogue output **DC/AC/PM/DU/RTD/OHM**
- projection on the display **DC/AC/PM/DU/OHM**

You can set the decimal point and the minus sign by repeatedly pressing .

Setting the decimal point proceeds from right and the minus sign follows in the highest decade of the entire continuous setting. Confirm your selection by pressing .

4.2 CONFIGURATION MODE





4.2.1 Entering the configuration mode

By pressing the keys  +  simultaneously and entering the correct access 4-digit password. From manufacture the password is always set on "0", which can be changed anytime as required.



In the event of loss of access password it is possible to use the universal number "8177"

4.2.2 Configuration mode - MENU

MENU  L IN LIMS  ANALOG (dARTA)  bR IGHT  CLreAr

4.2.2.1 Limits

L IN LIMS  L IN 1  L IN 2

L IN 1 Setting the limits switching

  →
↓

L IN 1

Setting Limit 1

- in this step the parameters „L IN“ (LIM) are set, upon which the limit shall react and is adjustable within the full range of the display, „HYS“ (HYS) an auxiliary parameter preventing oscillation upon unsteady value, is adjustable only in plus values Last parameter of the limit is „t INE“ (Time) determining delayed switch-on of the relay after exceeding the preset limit in the range of 0,0...99,9 s

 →

 L IN 1 1

Setting the limit within the full range of display projection

↓
 HYS 1

Setting hysteresis (only in plus values)

↓
t INE 1

Setting time delay for switch-on of the limit 0,0...99,9 s

L IN 2



Setting - Limit 2

- setting is the same as see LIM 1



4.2.2.2 Analogue output



ANALOG  **AO. n In**  **AO. nAh**

ANALOG Setting analogue output

  - The analogue output is isolated and its value corresponds with the displayed data. It is fully programmable, i.e. it allows to assign the AO limit points to any two arbitrary points of the entire measuring range. (e.g.: 600...800 ⇔ 4...20 mA) Maximum resolution of the output is 10000. The type of analogue output is adjustable - see page 14.

 →



AO. n In Assigning the displayed value to the beginning of the AO range
 - projection of the display is set in this step, which is valid for the beginning of the range of analogue output
  →

AO. nAh Assigning the displayed value to the beginning of the AO range
 - projection of the display is set in this step, which is valid for the end of the range of analogue output
  →



4.2.2.3 Data output



DATA  **BAUD**  **ADDR**

DATA Setting parameters of data output

  - dataoutput is isolated, either in the RS 232 nebo RS 485 finish. Both data lines are duplex, with the option of direct control and setting of the instrument (data protocol see. page 25)

 →

BAUD Setting the transmission rate
 - in range 150/300/600/1 200/2 400/4 800/9 600/19 200/38 400/
 /57 600/115 200 Baud
  →

ADDR Setting the instrument's address
 - range of the setting is 0...31
  →



In the instrument the analogue and data outputs cannot be recessed simultaneously!

4.2.2.4 Display brightness

br IGht ⌵

br IGht Setting the display brightness

- By selecting the display brightness we may react properly to light conditions in place of location of the instrument. Brightness is adjustable in five levels.
- In the programming menu the brightness is always 100 %.



- in range 10 % - 20 % - 40 % - 80 % - 100 %

4.2.2.5 Tare

CLrtAr ⌵

CLrtAr Tare resetting

- after confirmation of this data the tare is reset and LED „T“ light switches off



4.2.3 Configuration mode - CONFIG

CONF IG ⌵ CONF AD (CONF S) ⬆ CONF br ⬆ CONFtAr

One of the main advantages of this function is the possibility to grant authorisation for access and modification of parameters in individual steps of the "User mode". This setting shall facilitate the instruments operator easy control and shall prohibit an unauthorised interference into the setting of important functions.

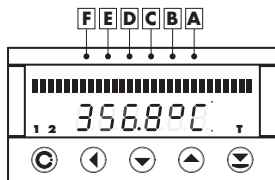

The configuration code may consist of up to 6 digits that determine the operational setting of the instrument. The individual signification and setting of numbers are described in relevant chapters of the configuration mode.

4.2.3.1 Limits

CO_{nL} IN  NE_{nUL}  FCE.L

CO_{nL} IN **Setting the attribute and the access rights for the „Limits“**



NE_{nUL}

Setting the access rights for the Limits menu

A - Limit 1, B - Limit 2



Rights for the "Limits" menu	Limits	Hysterez	Delay	BA
Restricted				0
Display	Yes			1
	Yes	Yes		2
	Yes	Yes	Yes	3
Change in setting	Yes			4
	Yes	Yes		5
	Yes	Yes	Yes	6

FCE.L

Configuration of the relay function

A - Limit 1 (relay 1), B - Limit 2 (relay 2)



Configuration of the relay function		BA
Relay	switch-on	0
	switch-off	1

4.2.3.2 Analogue output

CO_n AO  NE_{nU} AO  FCE.AOU

CO_n AO **Setting the attribute and access rights for the „Analogue output“**



NE_{nU} AO

Setting the access rights for the „Analog“ menu

- determines the function of the "Analog" menu in the User menu



Rights for the "Analog output" menu	A
Restricted	0
Display	1
Change in setting	2

FCEAD Setting the type of analogue output



-
- 0-5mA Current output 0...5 mA
 - ↓ 0-20mA Current output 0...20 mA
 - 4-20mA Current output 4...20 mA
 - 0-2V Potential output 0...2 V
 - 0-5V Potential output 0...5 V
 - 0-10V Potential output 0...10 V

4.2.3.3 Data output

CONRS

CONRS Setting the attribute and access rights for the „Data output“

- determines the function of the "Data" menu in the User menu



Rights for the "Data output" menu	A
Restricted	0
Display	1
Change in setting	2

4.2.3.4 Brightness

CONBR

CONBR Setting the attribute and access rights for the „Brightness“



Rights for the "BRIGHT" menu	A
Restricted	0
Display	1
Change in setting	2

4.2.3.5 Tare

COntAr 

COntAr **Setting the attribute and access rights for the „Tare“**

- determines the function of the "Tare" menu in the User menu







 →

Rights for the "Tare" menu	A
Restricted, fce Tare off	0
Display	1
Fce Tare on	2





4.2.4 Configuration mode - INPUT

In this step you can fully define the analogue output parameters.

DC/AC/W/PM

InPUt  0 In  NAK  F ILtEr  tYPE  rEAd  CHArS

DU

InPUt  0 In  NAK  F ILtEr  rEAd  CHArS

OHM

InPUt  0 In  NAK  LEAdS  F ILtEr  rEAd  CHArS

RTD

InPUt  0 FSEt  LEAdS  F ILtEr  rEAd

T/C

InPUt  CJC  F ILtEr  tYPE  rEAd  CONtC

4.2.4.1 Projection on the display

DC/AC/PM/OHM

InPUt  n Inn In Setting the projection of the beginning of the range

- in this programming step it is possible to set arbitrary projection on the display for the beginning of the input range of the instrument

InPUt  nRknRk Setting the projection of the end of the range

- in this programming step it is possible to set arbitrary projection on the display for the end of the input range of the instrument



DU

InPUt  n Inn In Setting the projection of the beginning of the range

- in this programming step it is possible to set arbitrary projection on the display for the beginning of the input range of the instrument

MERIT? Appeal to shift the potentiometer traveller into the initial position

- prior to confirmation of the „MERIT“ sign the potentiometer traveller has to be placed at the outset of the measuring range



Calibration for second position is identical with the setting of the outset

4.2.4.2 Shifting the range outset and compensation of the conduct

RTD

InPUt  OFSEt  LEAdSOFSEt Shifting the outset of the measuring range

- in cases where it is necessary to shift the range outset by a given value, e.g. when using sensor in measuring head, it is entered directly in Ohm



LEAdS



Compensation of the conduct (only 2-wire)

- for measuring accuracy it is necessary to perform compensation of the conduct always when 2-wire connection is used, it is entered directly in Ohm

YES



Confirmation of performance of automatic compensation of the conduct - prior to confirmation of the command it is necessary to replace the sensor at the end of the conduct by a short-circuit

- reconnect the sensor anew after calibration is completed



4.2.4.3 Setting the cold junction

T/C

INPUT CJC

CJC

Setting temperatures of cold junctions

- method and procedure of setting the cold junctions is described in separate chapter on page 25

- 0...98 °C with compensation box

- 99 °, without compensation box, wit/without reference thermocouple



4.2.4.4 Digital filter

INPUT ... FILTER

FILTER

Setting the digital filter

- use of digital filter finds its application where the change of projection on the display (by certain size) disturbs the maintenance or is not important in the measuring process

- it is set directly in digits and applies symmetrically

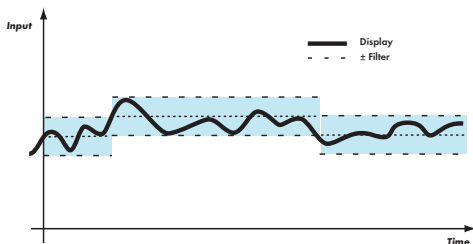

4.2.4.5 Type of input

DC/AC/PM/RTD/TC

Setting in this step depends on the type of instrument.

InPuT	 tYPE	
tYP	Setting the instrument's measuring range		DC/AC
	- ammeter and voltmeter are to individual instruments and switching between them is not possible		
	0- 60nV	0- 40nA	
	0- 150nV	0- 400nA	
	0- 300nV	0- 1A	
	0- 0.4u	0- 5A	
	0- 4u		
	0- 40u		
tYP	Setting the instrument's measuring range		PM
	0- 2u		
	0- 5u		
	0- 10u		
	0- 5mA		
	0- 20mA		
	4- 20mA		
tYP	Setting the type of connection		RTD
	2- u IrE	2-wire connection	
	3- u IrE	3-wire connection	
	4- u IrE	4-wire connection	
tYP	Setting the type of thermocouple		T/C
	b	thermocouple type B	
	r	thermocouple type R	
	S	thermocouple type S	
	t	thermocouple type T	
	E	thermocouple type E	
	J	thermocouple type J	
	K	thermocouple type K	
	n	thermocouple type N	



When changing the type of input or measuring range it is necessary to change the offset of jumpers (see page 22)!

4.2.4.6 Measuring rate

INPUT  ... rEAd

NErRS

Setting the measuring rate

- setting of the measuring rate is connected with the rate of response to the relay and analogue output switch-on

 →

 13 nrS	1,3 measurements/second
↓ 25 nrS	2,5 measurements/second
5 nrS	5 measurements/second
10 nrS	10 measurements/second
20 nrS	20 measurements/second
40 nrS	40 measurements/second

4.2.4.7 Measuring units

DC/AC/PM/DU/OHM

INPUT  ... CHArS

CHArS

Setting the measuring units

- setting the measuring unit (max. 2 characters), see table of page 24
- setting without displaying the units (0000), the data is centred
- when displaying the measuring units the displayed data is moved by one position to the left
- thermometer is with °C

 →

4.3.5 Configuration mode - Bargraph

Parameters of bargraph projection may be fully defined in this step.

bArGr.  n In  nAh  nOd  bAr.Gr.  bAr. 1r.  bAr. 2r.

4.3.5.1 Bargraph projection display

bArGr.  n In

n In

Setting the beginning of the bargraph range

- in this programming step we may set the display value which corresponds with the minimum bargraph projection

 →

bArGr.  ... nAh

nAh

Setting the end of the bargraph range

- in this programming step we may set the display value which corresponds with the maximum bargraph projection

 →



If $Min > Max$ is entered, then the projection on the bargraph is becoming shorter with the increasing display value

4.3.5.2 Setting the projection mode

bArGr.  ... nDE

nDE

Setting the bargraph projection mode

- to be set in the range of 0..6



- | | |
|---|---|
| 0 | bargraph is off |
| 1 | single-colour column, colour is set in entry Bar. OR |
| 2 | see 1, auxiliary display is off in the measuring mode |
| 3 | single-colour column with point identification of the limits, colour is set in the entry Bar. OR (red or green colour only) |
| 4 | see 3, auxiliary display is off in the measuring mode |
| 5 | three-colour column - the colour is determined by th limit value |
| | no limit colour is set in the entry Bar. OR |
| | one active limit colour is set in the entry Bar. 1R |
| | two active limits colour is set in the entry Bar. 2R |
| 6 | see 5, auxiliary display is off in the measuring mode |



Limits are accessible in the „Configuration menu“ even if the relays in the instrument are not fitted

4.3.5.3 Setting the LED colours

bAr. Or.  ... bAr. Or

bAr. Or

Setting the LED colours

- setting the colour column according to options in regime „MODE“



- | | |
|-------|---------------|
| rEd | red colour |
| GrEEr | green colour |
| OrAnG | orange colour |

Setting in menu „Bar. 1r“ a „Bar. 2r.“ is the same

5. INPUT CONFIGURATION

Jumpers are accessible after the instrument is opened.



J9 - Input "U" (PM)

3 - 4	0...2 V
2 - 5	0...5 V
1 - 6	0...10 V

J9 - Input "U" (DC)

NO	0...0,4 V
3 - 4	0...4 V
2 - 5	0...40 V
1 - 6	0...400 V

J5 - Type (RTD)

3 - 4	Pt 100
2 - 5	Pt 1 000/Ni 1 000
1 - 6	Pt 10 000/Ni 10 000



J7/8 - Type (T/C)

E, J, K, N	T, R, S	B
NO	NO	NC
NO	NC	NC



J7/8 - Input "I" (DC)

300 mV 5 A	150 mV 1 A	60 mV 400 mA
NO	NO	NC
NO	NC	NC

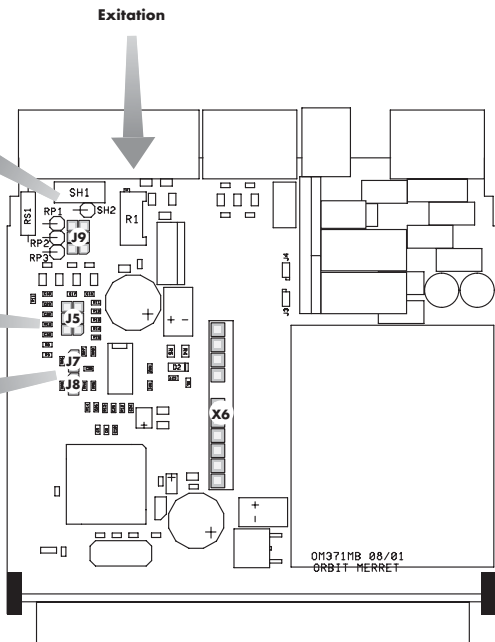

0M371MB 08/01
ORBIT-MERRET



Always disconnect the instrument from power supply while setting the jumpers up.



Setting the value of auxiliary voltage can be performed from the rear side of the instrument without the need to open it.

6. ERROR STATEMENTS

Errors	Reason	Elimination
<i>E.UNI</i>	Range underflow (A/D converter)	Change the value of input signal
<i>E.OVER</i>	Range overflow (A/D converter)	Change the value of input signal
<i>E.MATH</i>	Mathematics error Projection range is beyond the display	Adjust the projection value of the display
<i>E.MEM</i>	Wrong data storage	Upon repeated error statement send the instrument to have it repaired
<i>E. DATA</i>	Violation of data	Control of the setting of items in the menu
<i>E.CAL</i>	Loss of calibration data	Pre-set values will be used if it is necessary to send it for re-calibration

7. TABLE OF SYMBOLS

The following table lists all symbols that are projectable on a 14-segment display.

To set the measuring units use the sum of values in columns and lines by the required symbols in the table.

Example: mm \Rightarrow 77 77
without units \Rightarrow 00 00

	0	1	2	3	4	5	6	7		0	1	2	3	4	5	6	7
0		l	"	B	S	,	e	'	0	!	"	#	\$	%	&	'	
8	[]	H	+	,	-		°	8	()	*	+	,	-	.	/
16	0	1	2	3	4	5	6	7	16	0	1	2	3	4	5	6	7
24	8	9	=	.	c	=	o	°	24	8	9	:	;	<	=	>	?
32	J	R	b	C	d	E	F	G	32	@	A	B	C	D	E	F	G
40	H	I	J	K	L	M	N	O	40	H	I	J	K	L	M	N	O
48	P	Q	r	S	t	U	u	u	48	P	Q	R	S	T	U	V	W
56	H	Y	2	C	4	J	n	-	56	X	Y	Z	[\]	^	_
64	'	R	b	c	d	E	F	G	64	`	a	b	c	d	e	f	g
72	h	i	j	k	l	n	n	o	72	h	i	j	k	l	m	n	o
80	P	Q	r	S	t	u	u	u	80	p	q	r	s	t	u	v	w
88	H	Y	2	+	l	t	o		88	x	y	z	{		}	~	

8. MEASURING THE COLD JUNCTION

The OMB - T/C allows to set two types of measuring of cold junction.

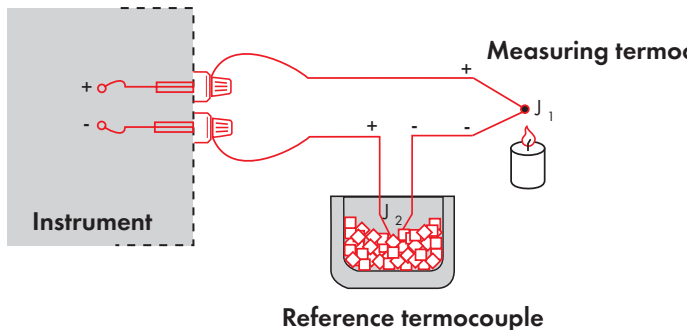

With reference thermocouple

- Reference thermocouple may be placed in the same place as the measuring instruments or in a place with stable temperature/compensation box.
- When measuring with reference thermocouple set the **COMPTE** in the instrument's menu to **YES**
- When using thermostat (compensation box or environment with constant temperature), set its temperature in the instrument's menu **TEC**.
- If the reference thermocouple is located in the same environment as the measuring instrument then set number 99 in the instrument's menu **TEC** Based on this selection measurement of the ambient temperature is performed by a sensor located in the terminal block of the instrument.

Without reference thermocouple

- Inaccuracy originating from the creation of different thermocouples on the junction connector-conductor is not compensated for in the instrument.
- When measuring without a reference thermocouple set the **COMPTE** in the instrument's menu to **NO**
- When measuring temperature without the use of reference thermocouple the error of measured data may be as high as 10°C.

9. COMMUNICATION PROTOCOL

Communication is performed with ASCII protocol (only printable symbols), which is identical for both lines RS 232/485

Data format

- 8 bit, no parity, no BCC

Request for data from display

Inquiry #AA<CR>

Response >r<SP>data<CR>

Legend

#	23 _H	beginning of the command
AA	00 _D +31 _D	two symbols (digits), instrument's address
<CR>	0D _H	carriage return
>	3E _H	beginning of data transmission

10. TECHNICAL DATA

Measuring range

selectable in the configuration menu

0...3,999 V	1 MOhm	Input U	DC
0...39,99 V	1 MOhm	Input U	
0...399,9 V	1 MOhm	Input U	
0...39,99 mA	< 260 mV	Input I	
0...399,9 mA	< 260 mV	Input I	
0...3,999 A	< 260 mV	Input I	

selectable in the configuration menu

0...60 mV	1 MOhm	Input I	AC
0...150 mV	1 MOhm	Input I	
0...600 mV	1 MOhm	Input I	
0...3,999 V	1 MOhm	Input U	
0...39,99 V	1 MOhm	Input U	
0...399,9 V	1 MOhm	Input U	
0...39,99 mA	< 260 mV	Input I	
0...399,9 mA	< 260 mV	Input I	

selectable in the configuration menu

0/4...20 mA	< 400 mV	Input I	PM
0...2 V	1 MOhm	Input U	
0...5 V	1 MOhm	Input U	
0...10 V	1 MOhm	Input U	

range is fixed, as per order

0...399,9	Ohm	OHM
0...3,999	Ohm	
0...39,99	kOhm	
0...100,0	kOhm	
5...105 Ohm		
Connection:	2 wire	

RTD

Pt 100/Pt 1000	-99,9°...399,9°C
Type:	100/1 000 Ohm, platinum couple $\alpha = 0,003850 \text{ Ohm/Ohm/}^\circ\text{C}$
Connection:	2, 3 or 4 wire

selectable in the configuration menu

Type:	J (Fe-CuNi)	0°...900°C	T/C
	K (NiCr-Ni)	0°...1 300°C	
	T (Cu-CuNi)	0°...400°C	
	E (NiCr-CuNi)	0°...690°C	
	B (PtRh30-PtRh6)	300°...1 820°C	
	S (PtRh10-Pt)	0°...1 760°C	

R (Pt13Rh-Pt)	0°...1 740°C
N (Omegalloy)	0°...1 300°C

DU

Power supply: of linear potentiometer 2,5 VDC/6 mA
min. potentiometer resistance is 500 Ohm

Projection

Display: Bargraph 30 LED - tricolours
Display, intensive red or green LED,
digit height 9 mm

Decimal point: adjustable - in configuration menu

Brightness: adjustable - in programming menu

Instrument accuracy

Temp. coefficient: 100 ppm/°C

Accuracy: $\pm 0,15\%$ of the range **DC/PM/DU**
 $\pm 0,5\%$ of the range **AC**
 $\pm 0,2\%$ of the range **OHM/RTD/TC**

Resolution: 0,1° **RTD**
1° **TC**

Rate: 1,3 - 2,5 - 5 - 10 - 20 - 40 measuring/s

Overload capacity: 10x (t < 100 ms), 2x (long-term)

Functions: Hold - holding the display (upon contact)
Digital filter - adjustable in configuration menu

Projection of measured units

Comp. of conduct: max. 40 Ohm **RTD**

CJC: adjustable **TC**
0°...98°C or automatic (99°)

Watch-dog: reset after 1,2 s

Calibration: at 23°C and 40 % relative humidity

Comparator

Type: digital, adjustable in the menu

Limits: -999...3999

Hysteresis: 0...999

Delay: 0...99,9 s

Outputs: 2x relays
- switch-on/switch-off contact
(230 VAC/30 VDC, 3 A)
- Solit state (230 VAC, 1 A)

Data outputs

Data format:	7 bit + even parity + 1 stop bit (DIN MESSBUS)
	8 bit + no parity + 1 stop bit (ASCII)
Rate:	150...115 200 Baud
Protocols:	DIN MESSBUS; ASCII
RS 232:	isolated, two-way communication
RS 485:	isolated, two-way communication, addressing (max. 31 instruments)

Analogue outputs

Type:	isolated, programmable with resolution 12 bit, analogue output corresponds with the displayed data
Non-linearity:	0,2 % of the range
TK:	100 ppm/°C
Rate:	response to change of value < 100 ms
Potential:	0...2 V/5 V/10 V
Current:	0...5/20 mA/4...20 mA - compensation of conduct up to 600 Ohm

Additional voltage**PM**

Adjustable:	2...24 VDC/50 mA, isolated
-------------	----------------------------

Power supply

	24/110/230 VAC/50 Hz
	9...32 VDC, max. 500 mA, isolated

Mechanical properties

Material:	Noryl GFN2 SE1, incombustible UL 94 V-I
Dimensions:	96 x 48 x 120 mm
Opening in panel:	90,5 x 45 mm

Operating conditions

Connection:	connector terminal board - conductor section up to 2,5 mm ²
Stabilisation period:	within 15 minutes after switch-on
Working temperature:	0°...60°C
Storage temperature:	-10°...85°C
Shielding:	IP64 (front panel only)
Construction:	Safety Class I
Overvoltage category:	EN 61010-1, A2 III. - instrument power supply (300 V) II. - input, output, excitation (300 V) for pollution degree II
EMC:	EN 61000-3-2+A12; EN 61000-4-2, 3, 4, 5, 8, 11; EN 550222, A1, A2

11. INSTRUMENT DIMENSIONS

Front view

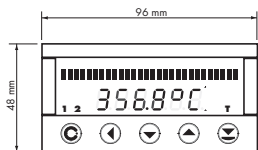

Panel cut

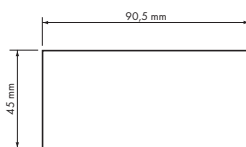

Side view

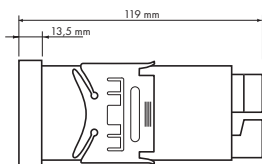

Panel thickness: 0,5...20 mm

Instrument mounting

1. insert the instrument into the panel cut out
2. put both the riders on the box
3. press the riders hard upon the panel

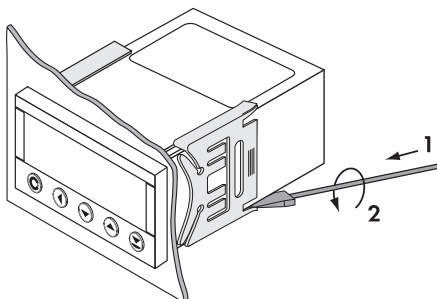
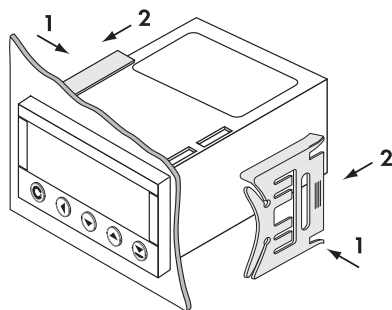

Instrument demounting

1. insert a screw-driver under the rider wing
2. turn the screw-driver and remove the rider
3. take the instrument out of the panel

12. CERTIFICATE OF GUARANTEE

Product: **OMB 301**
Type:
Manufacturing No.:
Date of sale:

For this instrument applies a guarantee period of 12 months of the date of sale to the user. Defects occurring during this period due to manufacturing error or due to material faults shall be eliminated free of charge.

For quality, function and construction of the instrument the guarantee shall apply provided that the instrument was connected and used accurately in compliance with the instructions for use.

The guarantee does not apply to defects caused by:

- mechanical damage
- in transport
- intervention of unqualified person incl. the user
- unavoidable event
- other unprofessional interventions

The manufacturer performs guarantee and post-guarantee repairs unless provided for otherwise.

Stamp, signature

ORBIT MERRET "FAX - INFO"

FAX: +420 - 2 - 8104 0299

If you wish to receive regular updated information about news in the line of our products, please fill in and send us the following form.

Company:.....

Name:.....

Function:

Department:

Address:.....

.....

City:

Telephone:.....

Fax:

E-mail:

Before sending this form by
fax, please, enlarge to
124 % (A5)
or
175 % (A4)

What is the nature of your company's business?.....

.....

.....

What measuring instruments produced by ORBIT MERRET™ do you use?

.....

.....

What measuring instruments produced by ORBIT MERRET™ are of interest to you?

.....

.....

What type of measuring instrument do you miss in our prospectus?.....

.....

.....

.....

.....