



# OMB 301

---

## PROGRAMMABLE BARGRAPH

DC VOLTMETER/AMMETER

PROCESS MONITOR

OHMMETER

THERMOMETER FOR PT 100/500/1 000

THERMOMETER FOR NI 1 000/2 226/10 000

THERMOMETER FOR THERMOCOUPLES

DISPLAY INSTRUMENT FOR LIN.

POTENTIOMETERS

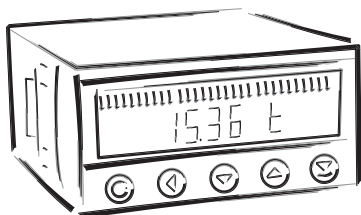

## SAFETY INSTRUCTIONS

Please, read the enclosed safety instructions carefully and observe them!  
These instruments should be safeguarded by isolated or common fuses (breakers)!  
For safety information the EN 61 010-1 + A2 standard must be observed.  
This instrument is not explosion-safe!

## TECHNICAL DATA

Measuring instruments of the OMB 301 series conform to European regulation 89/336/EWG.

They are up to the following European standards:

EN 55 022, class B

EN 61000-4-2, -4, -5, -6, -8, -9, -10, -11

The instruments are applicable for unlimited use in agricultural and industrial areas.

## CONNECTION

Power supply from the main line has to be isolated from the measuring leads.



## ORBIT MERRET, spol. s r.o.

Vodnanska 675/30  
198 00 Prague 9  
Czech Republic

Tel: +420 - 281 040 200  
Fax: +420 - 281 040 299  
e-mail: orbit@merret.cz  
www.orbit.merret.cz



<b>1. Contents</b> .....	<b>3</b>
<b>2. Instrument description</b> .....	<b>4</b>
<b>3. Connection</b> .....	<b>6</b>
<b>4. Instrument setting</b> .....	<b>8</b>
Setting the decimal point and the minus sign .....	9
Access into the configuration mode .....	9
4.1 Guide through minimum instrument setting .....	10
4.2 User MENU .....	12
4.2.1 Limits - entering the values .....	12
4.2.2 Analog output .....	13
4.2.3 Data output .....	13
4.2.4 Display brightness .....	13
4.2.5 Tare resetting .....	14
4.3 Configuration MENU .....	15
4.3.1 Configuration Mode - MENU .....	16
4.3.1.1 Limits .....	16
4.3.1.2 Analog output .....	17
4.3.1.3 Data output .....	17
4.3.1.4 Display brightness .....	18
4.3.1.5 Tare resetting .....	18
4.3.2 Configuration Mode - CONFIG .....	19
4.3.2.1.1 Setting Access into the limits Menu .....	19
4.3.2.1.2 Setting the relay function .....	20
4.3.2.2.1 Setting Access into the analog output menu .....	20
4.3.2.2.2 Setting the type of the analog output .....	20
4.3.2.3 Setting Access into the data output menu .....	21
4.3.2.4 Setting Access into the menu of brightness setting .....	21
4.3.2.5 Setting Access into the menu of tare resetting .....	21
4.3.3 Configuration Mode - INPUT .....	22
4.3.3.1 Projection on the display .....	23
Setting for linear potentiometer .....	23
4.3.3.2 Shifting the beginning of the range .....	23
4.3.3.3 Compensation of 2-wire conduct .....	24
4.3.3.4 Setting the type of connection .....	24
4.3.3.5 Setting the cold junction .....	24
4.3.3.6 Setting the Method of measurement of the cold junction .....	25
4.3.3.7 Digital filter .....	25
4.3.3.8 Setting the measuring range .....	26
4.3.3.9 Setting the measuring rate .....	27
4.3.3.10 Setting the description of measuring Units .....	27
4.3.4 Configuration Mode - BARGR .....	28
4.3.4.1 Bargraph projection display .....	28
4.3.4.2 Setting the projection mode .....	29
4.3.4.3 Setting the LED colours .....	29
<b>5. Configuration Input</b> .....	<b>30</b>
<b>6. Table of symbols</b> .....	<b>31</b>
<b>7. Method of meas. of the cold junction</b> .....	<b>32</b>
<b>8. Data protocol</b> .....	<b>33</b>
<b>9. Error statements</b> .....	<b>34</b>
<b>10. Instrument dimensions and instal.</b> .....	<b>35</b>
<b>11. Technical data</b> .....	<b>36</b>
<b>12. Declaration of conformity</b> .....	<b>38</b>
<b>13. Certificate of guarantee</b> .....	<b>39</b>

DC	PM	DU	OHM
----	----	----	-----

DU

RTD

OHM RTD

RTD

T/C

T/C

DC

PM

RTD

OHM

T/C

DC

PM

DU

OHM

3

## 2. INSTRUMENT DESCRIPTION

### DESCRIPTION

The OMB 301 model line are horizontal bargraphs with tri-color 30 LED with auxiliary 6-digit display, manufactured in the following alternatives:

OMB 301DC	DC voltmeter/ammeter
OMB 301PWR	*Nets analyser - AC voltmeter/ammeter/wattmeter
OMB 301PM	Process monitor
OMB 301RTD	Thermometer for Pt 100/500/1 000, Ni 1 000/2 226/10 000
OMB 301T/C	Thermometer for thermocouples
OMB 301DU	Display instrument for linear potentiometers
OMB 301OHM	Ohmmeter

The instruments are based on an 8-bit microcontroller with precise A/D converter, that secures high accuracy, stability and easy operation of the instrument.

#### Programmable projection of the display

Calibration	projection for the beginning and the end of the input range setting the type of input
Projection	30 LED with adjustable color of projection (red - green - orange) 6-digit auxiliary display

#### Digital filters

Radius of insensitiveness adjustable in process units

#### Mathematic functions

Tare	assigned to reset the display in case of non-zero input signal
------	--

#### External control

Hold	display/instrument blocking
Lock	locking the control keys or the access into Configuration menu

\* These instruments have separate Instructions for use

## OPERATION

The instrument is set and controlled by five control keys located on the front panel. All programmable settings of the instrument are realised in two adjusting modes:

- Configuration menu** (hereinafter referred to as „CM“) is protected by an optional numeric code and contains complete instrument setting
- User menu** may contain arbitrary programming setting defined in CM with another selective restriction (see, change)

All programmable parameters are stored in the EEPROM memory (they hold even after the instrument is switched off).

The measured units may be projected on the display.

## EXTENSION

**Excitation** is suitable for feeding of sensors and converters. It has a galvanic isolation with continuously adjustable value in the range of 2...24 VDC.

**Dual comparator** is designed to monitor two limit values with relay output. Limits have adjustable hysteresis as well as selectable delay of the switch-on. Reaching the preset limits is signalled by LED and at the same time by the switch-on of the relevant relay.

**Data outputs** are for their rate and accuracy suitable for transmission of measured data for further projection or directly into the control systems. We offer isolated RS232 and RS485 with the ASCII protocols.

**Analog outputs** will find their place in applications where further evaluating or processing of measured data in external devices is required. We offer universal analog output with the option of selection of the output type - voltage/current. The analog output value corresponds with the displayed data and its type and range are selectable in the programming mode.

### 3. CONNECTION

The supply lead for feeding the instrument should not be in the proximity of low-potential signals.  
 Contactors, motors with larger input and other efficient elements should not be in the proximity of the instrument.  
 The lead into the instrument input (the measured quantity) should be in sufficient distance from all power leads and appliances. Provided this cannot be secured, it is necessary to use shielded leads with connection to ground.  
 The instruments are tested in compliance with standards for use in industrial area, yet, we recommend to abide by the above mentioned principles.

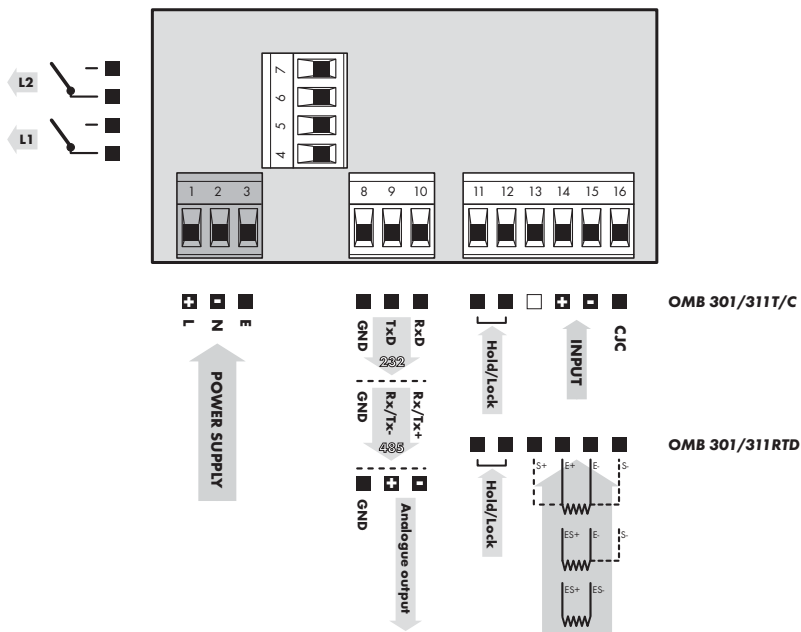

! Grounding on terminal „E“ must be connected at all times

! In RTD input with 2- or 3-wire connection it is necessary to link the unconnected inputs (13/14 and 15/16 or 15/16)

! Relay parameters specified in the technical data apply for resistance load. Upon connection of the induction load we recommend to fit the leads to relay 1 A with a fuse for maximum load protection.

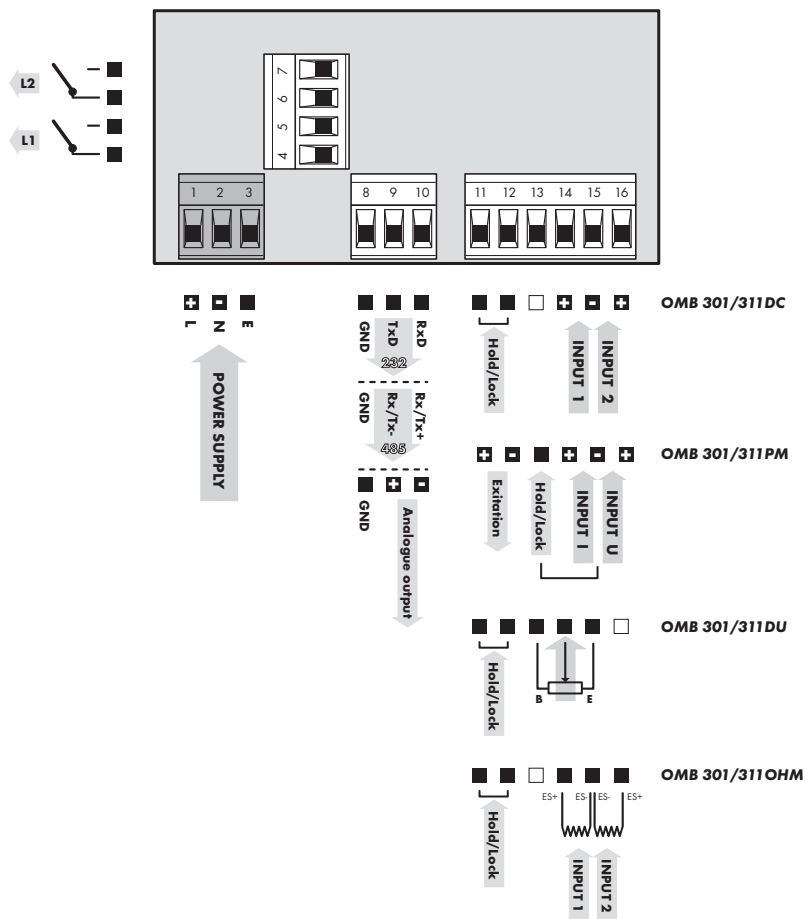

### MEASURING RANGES

Type	Input 1 (I)	Input 2 (U)
OMB 301 DC - U	0...60/150/300 mV	0...4/40/400 V
OMB 301 DC - I	0...1/5 A	0...400 mA
OMB 301 PM	0/4...20 mA	0...2/5/10 V
OMB 301 OHM	0...0,4/4/40 kOhm	5...105 Ohm, (upon request 0...100 kOhm)

## 4. INSTRUMENT SETTING

The instrument is set and controlled by 5 control keys located on the front panel. By means of these control keys it is possible to browse through the operating program, to select and set the required values.

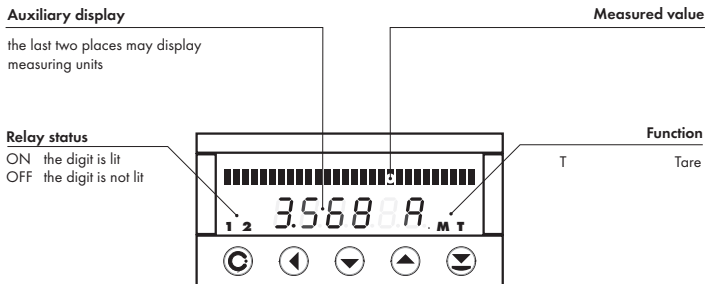

### CONFIGURATION MODE

- designated for professional service and maintenance
- complete instrument setting
- access is password protected
- authorization for "User mode"

### USER MODE

- designated for instrument service
- may contain setting the limits, analog and data output and brightness, with restriction as per the setting in "Configuration mode"

### SYMBOLS USED IN THE INSTRUCTIONS

**DC** **PM** **DU** **OHM** **RTD** **T/C**

Indicates the setting for given type of instrument



### CONTROL KEYS FUNCTIONS

MENU	ENTER	LEFT	DOWN	UP
<b>Measuring mode</b>				
menu access	tare	tare projection		
<b>Moving around in the menu</b>				
exit the menu without saving	move to next level	back to previous level		move to next item
<b>Setting/selecting - items</b>				
cancel setting without saving	confirm selected item		move down	move up
<b>Setting - numbers</b>				
cancel setting without saving	cancel selected number	move to higher decade	change of current figure - down -	change of current figure - up -



## SETTING THE DECIMAL POINT AND THE MINUS SIGN

### DECIMAL POINT

Its selection in calibration modes, upon modification of the number to be adjusted is performed by the control key  with transition behind the highest decade, when the decimal point starts flashing. Positioning is performed by . Decimal point is set only in the item „Input - MIN“





### MINUS SIGN

It is adjustable upon the shift of the decimal point across all decades, back to the first one, at which the minus sign will light up. The setting is repeated, i.e. 1x around only positioning of the decimal point and upon next passage across all decades the minus sign lights up and the decimal point is placed.



### Setting

⇒ „Calibration mode“ ⇒ Input ⇒ Minimum  
⇒ *INPUt* ⇒ *n In*

⇒ after transition behind the highest decade  the decimal point starts flashing  
⇒ by pressing  or  you will place the decimal point and confirm it by 

**!** In the MIN item the setting of the decimal point is determining for the entire instrument

## ACCESS INTO THE CONFIGURATION MODE

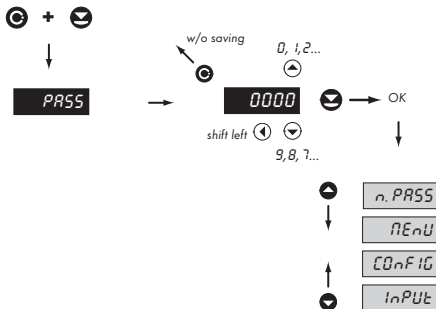

**!** The code is always preset from manufacture to 0000. In case of loss of access password it is possible to use universal access code "8177"

## 4.1 GUIDE THROUGH MINIMUM INSTRUMENT SETTING

### 1 Access into the „Configuration menu“

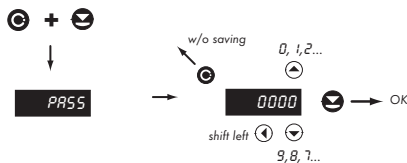

**PASS** Entering the introductory access password

**0000** Standard manufacture setting of the access password

### 2 Selection of the meas. range/type of input

**DC PM OHM RTD T/C**

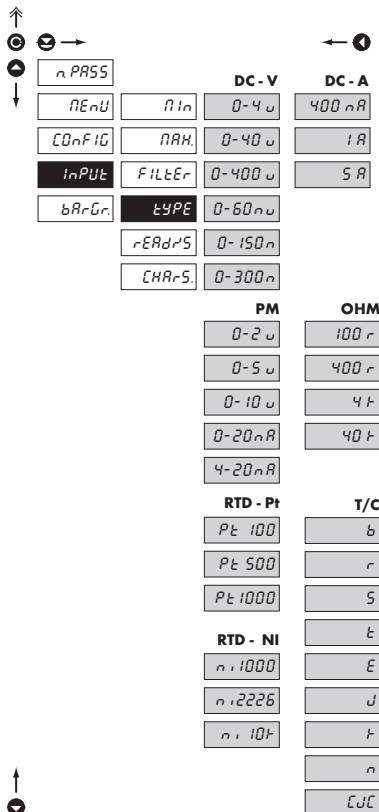

**TYPE** Setting the instrument measuring range

#### DC Input

- ammeter and voltmeter are two independent instruments

#### PM Input

- setting the measuring range

#### RTD Input

- setting the type of sensor  
 - Pt 3850 ppm/ $^{\circ}$ C EU, standard  
 - Pt 3920 ppm/ $^{\circ}$ C US, upon request  
 - Ni 5000 ppm/ $^{\circ}$ C standard  
 - Ni 6180 ppm/ $^{\circ}$ C upon request

#### OHM Input

- setting the measuring range  
 - 100 R 5...105 Ohm  
 (100 K 0...100 kOhm), upon request  
 400 R 0...400 Ohm  
 4 K 0...4 kOhm  
 40 K 0...40 kOhm

#### T/C Input

- setting the type of thermocoupler  
 - B type B  
 R type R  
 S type S  
 T type T  
 E type E  
 J type J  
 K type K  
 N type N  
 CJC the temperature of the cold junction

### 3 Setting projection on the display

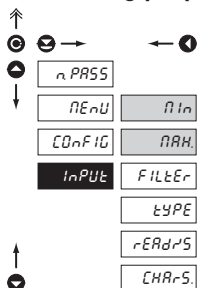

### 4 Setting the projection mode

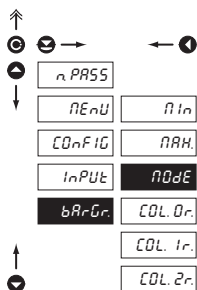

### 5 Setting the LED colours

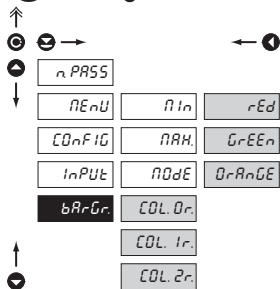

#### INPUT Setting the input parameters

Type of input	Displayed items of the menu
DC	MIN, MAX
PM	MIN, MAX
DU	MIN, MAX
OHM	MIN, MAX, *LEADS
RTD	*LEADS, CONNEC.
T/C	CJC, COMP.TC

\* only for 2-wire

#### MODE Setting the bargraph projection mode

- to be set in the range of 0...6

- bargraph is off
- single-colour column, colour is set in entry Col. 0R
- single-colour column with point identification of the limits, colour is set in the entry Col. 0R (red or green colour only)
- see 3, auxiliary display is off in the measuring mode
- three-colour column - the colour is determined by the limit value
  - no limit colour is set in the entry Col. 0R
  - one active limit colour is set in the entry Col. 1R
  - two active limits colour is set in the entry Col. 2R
- see 5, auxiliary display is off in the measuring mode

#### COL. 0r. Setting the bargraph LED colours

- setting the colour column according to options in regime „MODE“

RED	red colour
GREEN	green colour
ORANGE	orange colour

## 4.2 USER MENU

- designated for instrument service
- may contain setting the limits, analog/data output and brightness, with restriction as per the setting in "Configuration mode"

23.6



MENU

LIMITS

ANALOG

DATA

BRIGHT.

CLEAR.

MENU

Setting limits,  
hysteresis and  
delay

Setting the  
analog output

Setting the data  
output

Setting the  
display  
brightness

Tare resetting

Instrument setting

**!** Projection of items and their accessibility depends on the setting of access rights in the „Configuration menu“

### 4.2.1 LIMITS - ENTERING THE VALUES

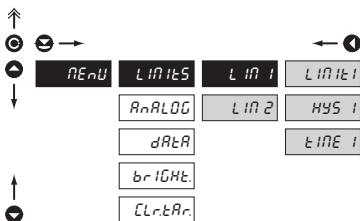

LIMITS

Entering the limit values  
for status evaluations

LIMIT 1

Setting for Limit 1

LIMIT 2

Setting for Limit 2

LIMIT 1

Setting the limit for relay  
switch-on

- in full range of the display

HYS 1

Setting hysteresis only in  
(+) values

- in 1/10 of the display range

TIME 1

Setting the delay of relay  
activation

- in the range of 0...99,9 s



Adjustable authorization of access into items,  
see page 19

## 4.2.2 ANALOG OUTPUT

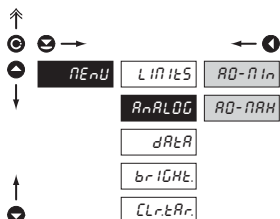

Adjustable authorization of access into items, see page 20

Analog and data outputs may not be fitted simultaneously in this instrument

### ANALOG Setting the analog output range

- analog output is isolated and its value corresponds with the displayed data. It is fully programmable, i.e. it allows to assign the AO limit points to any two arbitrary points of the entire measuring range

**AO-PIA** Assigning the displayed value to the beginning of the analog output range

- range of the setting is -999...3999

**AO-PAH** Assigning the displayed value to the end of the analog output range

- range of the setting is -999...3999

## 4.2.3 DATA OUTPUT

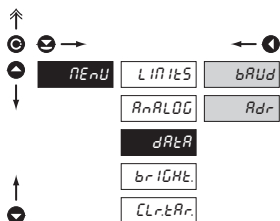

Adjustable authorization of access into items, see page 21

### DATA Setting the data output parameters

**BAUD** Setting the transmission rate (baud)

- setting in the range of 150/300/600/1200/2400/4800/9600/19200/38400/57600/115200 Baud

**ADR** Setting the instrument address

- setting in the range of 0...31
- manufacture setting 00 **DEF**

## 4.2.4 DISPLAY BRIGHTNESS

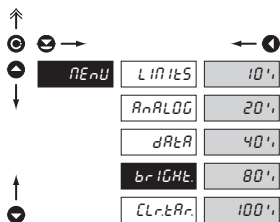

### BRIGHT Setting the display brightness

- by selecting the display brightness we may properly react to light conditions in place of location of the instrument
- brightness in the programming menu is always 80%

Adjustable authorization of access into items, see page 21

## 4.2.5 TARE RESETTING

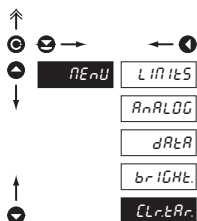

### CLr.tAr. Tare resetting

- after confirmation the tare will be reset to zero and the LED „T“ will turn off

 Adjustable authorization of access into items, see page 21

## 4.3 CONFIGURATION MENU

- designated for professional service and maintenance
- complete instrument setting
- the access is protected by a password or a jumper on the input connector
- authorization for "User mode"

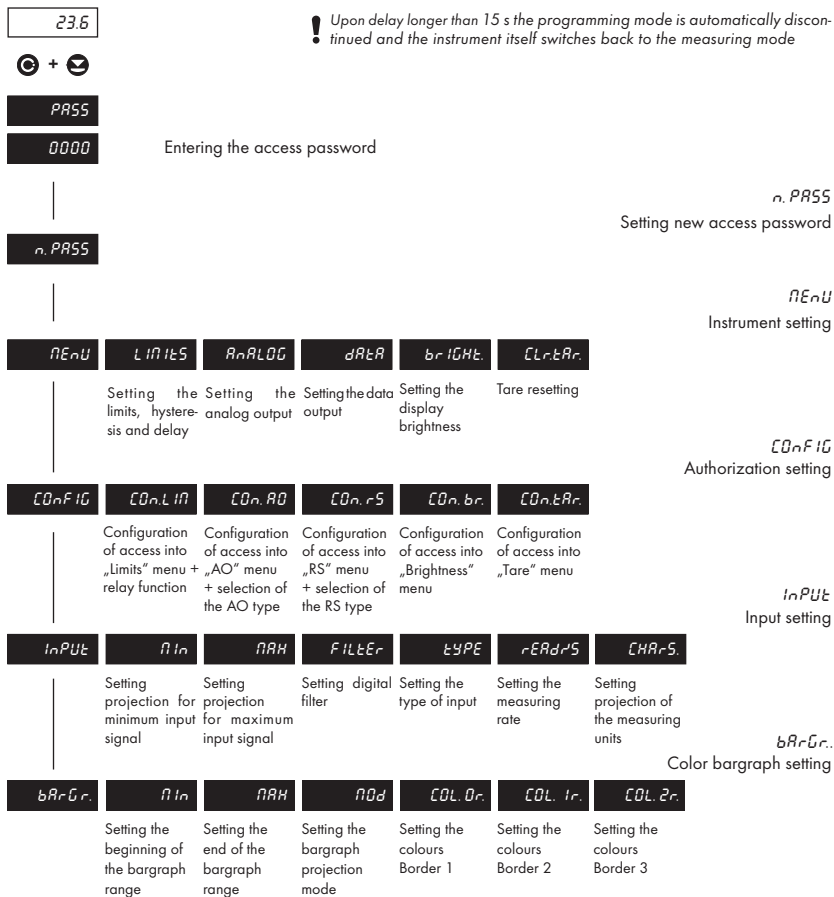

### 4.3.1 CONFIGURATION MODE - MENU

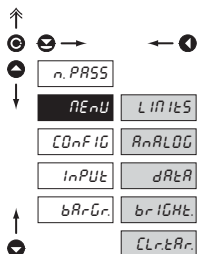

The basic instrument parameters are adjusted in this menu

LIMITS	Setting the limit values for status evaluation
ANALOG	Setting the analog output range
dAREA	Setting the data output parameters
bRIGHL	Setting the display brightness
CLr.tARr	Tare resetting

#### 4.3.1.1 LIMITS

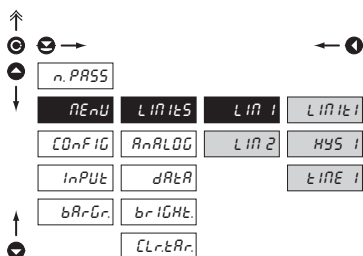

! The procedure of setting the limit 2 is identical as for limit 1

#### LIMITS Entering the limit values for status evaluation

LIN 1	Setting for Limit 1
LIN 2	Setting for Limit 2

LIMIT 1 Setting the limit for relay switch-on  
- in full range of the display

HYS 1 Setting hysteresis only in (+) values  
- in 1/10 of the display range

TIME 1 Setting the delay for relay activation  
- in the range of 0...99,9 s

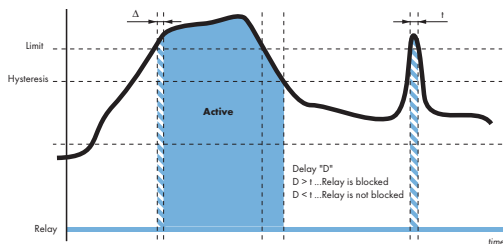

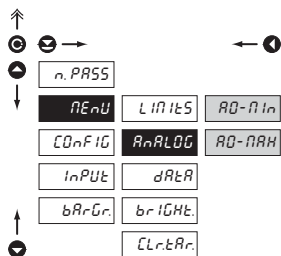

## 4.3.1.2 ANALOG OUTPUT

**ANALOG** Setting the analog output range

- analog output is isolated and its value corresponds with the displayed data. It is fully programmable, i.e. it allows to assign the AO limit points to any two arbitrary points of the entire measuring range

**AO-POIN** Assigning the displayed value to the beginning of the AO range

- range of the setting is -999...3999

**AO-RANGE** Assigning the displayed value to the end of the AO range

- range of the setting is -999...3999

! Analog and data outputs may not be fitted simultaneously in this instrument

## 4.3.1.3 DATA OUTPUT

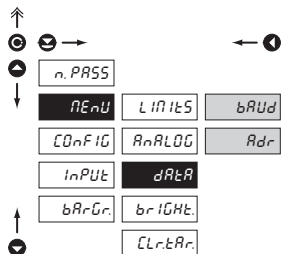
**dRtR** Setting the data output parameters

**bRtD** Setting the transmission rate (baud)

- setting in the range of 150/300/600/1200/2400/4800/9600/19200/38400/57600/115200 Baud

**Adr** Setting the instrument address

- setting in the range of 0...31

- manufacture setting 00 **DEF**

! Analog and data outputs may not be fitted simultaneously in this instrument

## 4.3.1.4 DISPLAY BRIGHTNESS

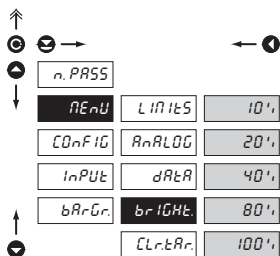

## bRIGHt. Setting the display brightness

- by selecting the display brightness we may react properly to light conditions in place of location of the instrument
- brightness in the programming menu is always 100%

10%	Display brightness = 10%
20%	Display brightness = 20%
40%	Display brightness = 40%
80%	Display brightness = 80%
100%	Display brightness = 100%

## 4.3.1.5 TARE RESETTING

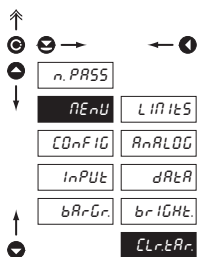

## CLr.tRr. Tare resetting

- after confirmation the tare will be reset to zero and the LED „T“ will turn off

### 4.3.2 CONFIGURATION MODE - CONFIG

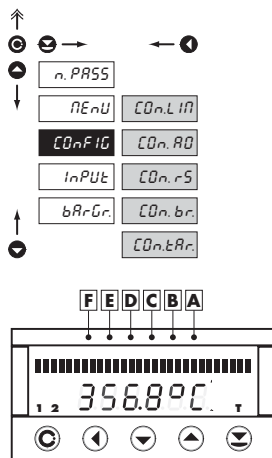

The configuration code may consist of up to 6 numbers, which determine the operational setting of the instrument. Individual meaning and setting of the numbers are described in relevant chapters of the configuration mode.

#### **CO n.FIG** Setting the access rights to individual options for „User mode“

- one of the prime merits of this function is the feasibility to assign authorization for access and modification of parameters in individual steps of the "User mode". This setting will facilitate the instrument service staff easy operation and prevent unauthorized interference into the setting of vital functions.

**CO n.L IM** Configuration of the access into „Limits“ menu and relay function

**CO n. AO** Configuration of the access into „AO“ menu and selection of the AO type

**CO n. rS** Configuration of the access into „RS“ menu

**CO n. br.** Configuration of the access into „Brightness“ menu

**CO n. tARr.** Configuration of the access into „Tare“ menu

#### 4.3.2.1.1 SETTING ACCESS INTO THE LIMITS MENU

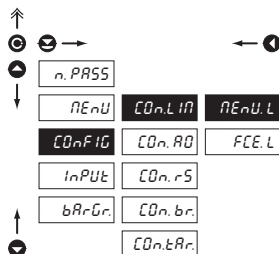

#### **CO n.L IM** Configuration of the access into „Limits“ menu and relay function

#### **nEnU.L** Setting the access rights

- selection of the access rights for „User mode“

A - Limit 1, B - Limit 2

Rights	Limits	Hyst.	Time	BA
Prohibited	x	x	x	0
	✓	x	x	1
Projection	✓	✓	x	2
	✓	✓	✓	3
Change of setting	✓	x	x	4
	✓	✓	x	5
	✓	✓	✓	6

## 4.3.2.1.2 SETTING THE RELAY FUNCTION

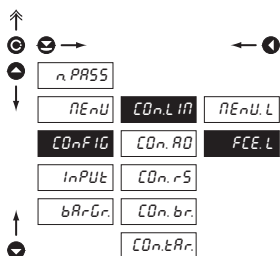
**FCE.L** Relay configuration

A - Limit 1

B - Limit 2

Relay fuunction		BA
Relay	switch-on	0
	switch-off	1

## 4.3.2.2.1 SETTING ACCESS INTO THE ANALOG OUTPUT MENU

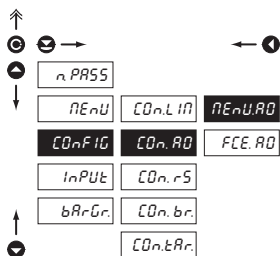
**CO n.AO** Configuration of the access into „AO“ menu and selection of the AO type**nEnU.AO** Setting the access rights

- selection of the access rights for „User mode“

Rigts	A
Prohibited	0
Projection	1
Change of setting	2

## 4.3.2.2.2 SETTING THE TYPE OF THE ANALOG OUTPUT

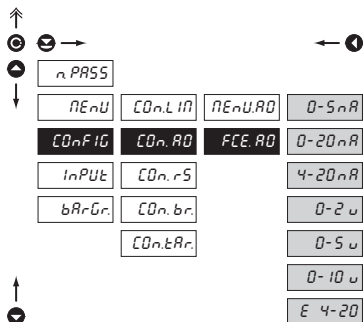
**FCE.AO** Setting the type of the analog output**0-5 nA** Range - 0...5 mA**4-20 nA** Range - 0...20 mA**0-20 nA** Range - 4...20 mA**0-2 u** Range - 0...2 V**0-5 u** Range - 0...5 V**0-10 u** Range - 0...10 V**E 4-20** Range - 4...20 mA with indication „ERROR“

- upon error statement the value on the output is &lt; 3,6 mA

## 4.3.2.3 SETTING ACCESS INTO THE DATA OUTPUT MENU

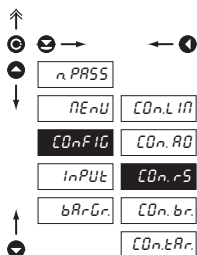

## CO\_n.r5 Setting the access rights

- selection of the access rights for the „User mode“

Rights	A
Prohibited	0
Projection	1
Change of setting	2

## 4.3.2.4 SETTING ACCESS INTO THE MENU OF BRIGHTNESS SETTING

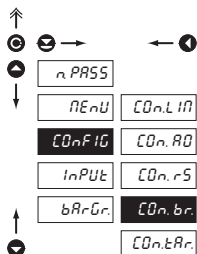

## CO\_n.br. Configuration of the access into „Brightness“ menu

- selection of access rights for the „User mode“

Rights	A
Prohibited	0
Projection	1
Change of setting	2

## 4.3.2.5 SETTING ACCESS INTO THE MENU OF TARE RESETTING

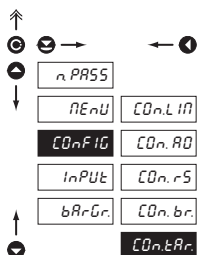

## CO\_n.tAR. Configuration of the access into tare resetting

- selection of access rights for the „User mode“

Rights	A
Prohibited, the function is off	0
Projection	1
Resetting to zero permitted	2

### 4.3.3 CONFIGURATION MODE - INPUT

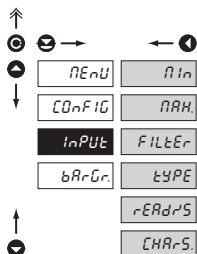

#### InPUt Setting the input parameters

<b>nIn</b>	Setting display projection for minimum value of the input signal ①
<b>nRnH</b>	Setting display projection for maximum value of the input signal ②
<b>FiLteR</b>	Setting the digital filter ③
<b>OFFSEt</b>	Shift of the beginning of the measuring range ④
<b>LEAdS</b>	Compensation of 2-wire conduct ⑤
<b>tYPE</b>	Setting the instrument meas. range and connection ⑥
<b>CONnEC.</b>	Setting the type of input connection ⑦
<b>rERdRS</b>	Setting the instrument measuring rate ⑧
<b>CHArS.</b>	Setting the projection of measuring units ⑨
<b>CJC</b>	Setting the temperature of the cold junction ⑩
<b>CONPLeC</b>	Method of measurement of the cold junction ⑪

Input type	Setting options
DC	① ② ③ ⑥ ⑧ ⑨
PM	① ② ③ ⑥ ⑧ ⑨
DU	① ② ③ ⑧ ⑨
OHM	① ② ③ ⑤ ⑧ ⑨
RTD	③ ④ ⑤ ⑥ ⑦ ⑧
T/C.	③ ⑥ ⑧ ⑩ ⑪



## 4.3.3.3 COMPENSATION OF 2-WIRE CONDUCT

OHM RTD

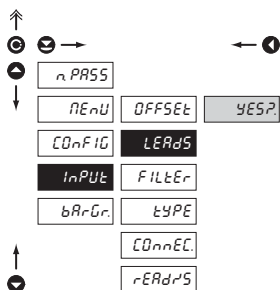

## LEAdS Compensation of 2-wire conduct

- for measurement accuracy it is necessary to perform compensation of the conduct always in case of 2-wire connection
- entered directly in Ohm
- prior to confirmation of the displayed challenge „YES?“ it is necessary to substitute the sensor at the end of the conduct by a short circuit
- preset from manufacture to „0“

! The items are visible at all times but the active only upon set 2-wire connection

## 4.3.3.4 SETTING THE TYPE OF CONNECTION

RTD

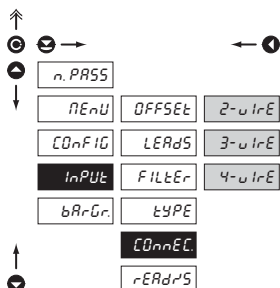

## tYPE Setting the type of connection

- 2-w IrE 2-wire input connection
- 3-w IrE 3-wire input connection
- 4-w IrE 4-wire input connection

## 4.3.3.5 SETTING THE COLD JUNCTION

T/C

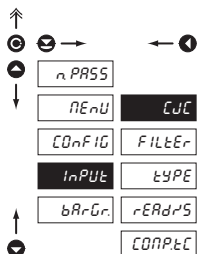

## CJt Setting the temperature of the cold junction

- range of 0...98 °C with compensation box
- 99 °C without compensation box, with/without reference thermocouple, temperature of the cold junction is measured at the input brackets of the instrument

! Method and procedure of the setting of the cold junctions are described in a separate chapter on page 32



## 4.3.3.6 SETTING THE METHOD OF MEASUREMENT OF THE COLD JUNCTION

T/C

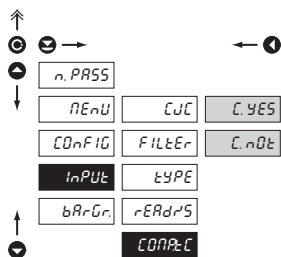
**CONFtC** Setting the method of measurement of the cold junction

- measurement with/without reference thermocouple

**C.YES** Measurement with reference thermocouple (antiserially)

**C.NoT** Measurement without reference thermocouple

Method and procedure of setting of the cold junctions are described in a separate chapter on page 32

## 4.3.3.7 DIGITAL FILTER

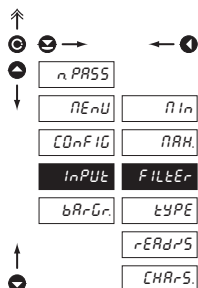

**FILTER** Setting the digital filter

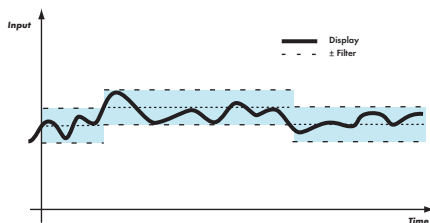
- use of the digital filter will find its place in applications where the change of projection on the display (by given value) interferes or is not substantial in the measuring regime
- it is entered directly in digits and is valid symmetrically



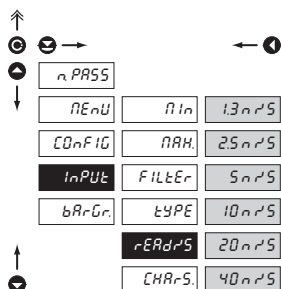

## 4.3.3.9 SETTING THE MEASURING RATE

**rERdPS** Setting the measuring rate

- setting the measuring rate is associated with the rate of response to evaluation of the relay status and analog output

1.3 nPS Rate - 1,3 measurements/s

2.5 nPS Rate - 2,5 measurements/s

5 nPS Rate - 5 measurements/s

10 nPS Rate - 10 measurements/s

20 nPS Rate - 20 measurements/s

40 nPS Rate - 40 measurements/s

## 4.3.3.10 SETTING THE DESCRIPTION OF MEASURING UNITS

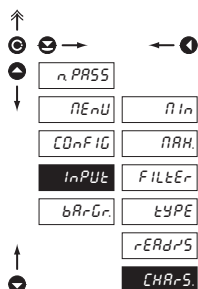
**DC PM DU OHM****CHArS** Setting projection of measuring units on the display

- the instrument allows to add two descriptive characters to the classic numeric formats (at the expense of the number of displayed places). The setting is performed by means of a shifted ASCII code. Upon setting the first two places display the entered characters and the last two places the code of the relevant symbol from 0 to 95.

Description is cancelled by entering characters 00

- instruments with the input for temperature measurement display as a standard °C

 Table of symbols is on page 31

### 4.3.4 CONFIGURATION MODE - BARGR.

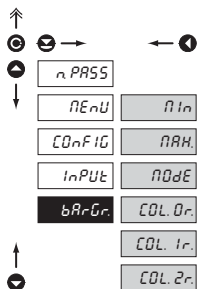

#### bARGr. Nastavení parametrů bargrafu

nIn	Setting the beginning of the bargraph range
nRH	Setting the end of the bargraph range
nDd	Setting the bargraph projection mode
COl. 0r.	Setting the colours Border 1
COl. 1r.	Setting the colours Border 2
COl. 2r.	Setting the colours Border 3

#### 4.3.4.1 BARGRAPH PROJECTION DISPLAY

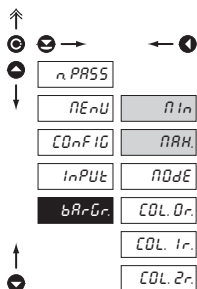

nIn	Setting the beginning of the bargraph range
- in this programming step we may set the display value which corresponds with the minimum bargraph projection	
nRH	Setting the end of the bargraph range
- in this programming step we may set the display value which corresponds with the maximum bargraph projection	

 If  $Min > Max$  is entered, then the projection on the bargraph is becoming shorter with the increasing display value

## 4.3.4.2 SETTING THE PROJECTION MODE

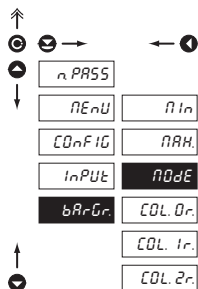

Limits are accessible in the „Configuration menu“ even if the relays in the instrument are not fitted

### nOd

#### Setting the bargraph projection mode

- to be set in the range of 0...6
- 0 bargraph is off
- 1 single-colour column, colour is set in entry Col. 0R
- 2 see 1, auxiliary display is off in the measuring mode
- 3 single-colour column with point identification of the limits, colour is set in the entry Col. 0R (red or green colour only)
- 4 see 3, auxiliary display is off in the measuring mode
- 5 three-colour column - the colour is determined by th limit value
 

no limit	colour is set in the entry Col. 0R
one active limit	colour is set in the entry Col. 1R
two active limits	colour is set in the entry Col. 2R
- 6 see 5, auxiliary display is off in the measuring mode

## 4.3.4.3 SETTING THE LED COLOURS

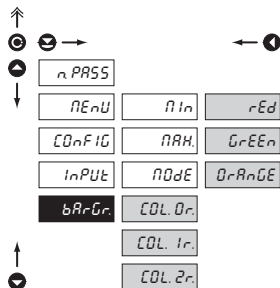

### COl. 0r.



#### Setting the bargraph LED colours

- setting the colour column according to options in regime „MOdE“
- RED red colour
- GREEN green colour
- ORANGE orange colour



Setting in menu „Col. 1r“ and „Col. 2r.“ is the same

## 5. CONFIGURATION INPUT

Jumpers are accessible after the instrument is opened

		INPUT "2" (DC)	60 mV	150 mV	300 mV
	Not	X	✓	✓	✓
	Yes	✓	X	X	X
	Not	X	X	X	X
	Yes	X	X	X	X

		INPUT "2", "U"	DC	PM
	5 - 6	0...4 V	0...2 V	
	3 - 4	0...40 V	0...5 V	
	1 - 2	0...400 V	0...10 V	

		INPUT (T/C)	E, J, K, N	T, R, S	B
	Not	✓	✓	X	X
	Yes	X	X	✓	✓
	Not	✓	X	X	X
	Yes	X	✓	✓	✓

		INPUT	RTD
	5 - 6	Pt 100/Ni 1 000	
	3 - 4	Pt 500/Ni 2 226	
	1 - 2	Pt 1 000/Ni 10 000	

		INPUT	OHM - Input 1
	5 - 6	0...400 Ohm	
	3 - 4	0...4 kOhm	
	1 - 2	0...40 kOhm	

		FUNKTIONEN	Hold	Lock
	Not	✓	✓	X
	Yes	X	X	✓

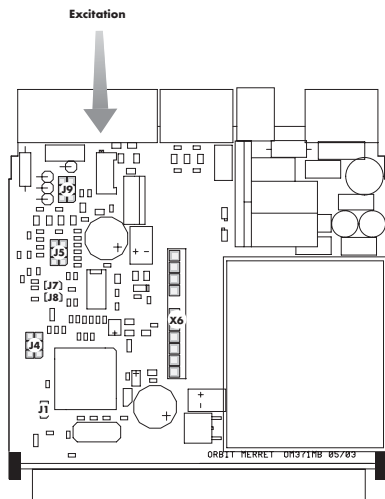

! For every jumper setting disconnect the instrument from the mains

## 6. TABLE OF SYMBOLS

The instrument allows to add two descriptive characters to the classic numeric formats (at the expense of the number of displayed places). The setting is performed by means of a shifted ASCII code. Upon modification the first two places display the entered characters and the last two places the code of the relevant symbol from 0 to 95. Numeric value of given character equals the sum of the numbers on both axes of the table.

Description is cancelled by entering characters with code 00

	0	1	2	3	4	5	6	7		0	1	2	3	4	5	6	7	
0		!	"	#	\$	%	&	'		0	!	"	#	\$	%	&	'	
8	[	]	H	I	,	-	.	/		8	(	)	*	+	,	-	.	/
16	0	1	2	3	4	5	6	7		16	0	1	2	3	4	5	6	7
24	8	9	:	;	<	=	>	?		24	8	9	:	;	<	=	>	?
32	J	K	L	M	N	O	P	Q		32	@	A	B	C	D	E	F	G
40	H	I	J	K	L	M	N	O		40	H	I	J	K	L	M	N	O
48	P	Q	R	S	T	U	V	W		48	P	Q	R	S	T	U	V	W
56	H	Y	Z	[	\	]	^	_		56	X	Y	Z	[	\	]	^	_
64	'	a	b	c	d	e	f	g		64	`	a	b	c	d	e	f	g
72	h	i	j	k	l	m	n	o		72	h	i	j	k	l	m	n	o
80	P	q	r	s	t	u	v	w		80	p	q	r	s	t	u	v	w
88	H	y	z	{		}	~			88	x	y	z	{		}	~	

## 7. METHOD OF MEAS. OF THE COLD JUNCTION

An instrument with input for temperature measurement with thermocouple allows for setting of two types of measurement of the cold junction.

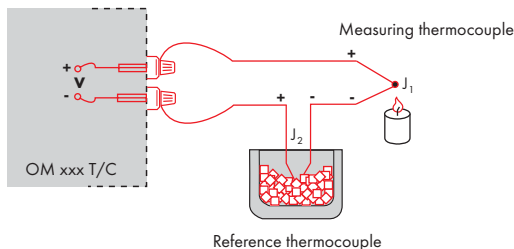

### WITH REFERENCE THERMOCOUPLE

- a reference thermocouple may be located in the same place as the measuring instrument or in place with stable temperature/compensation box
- when measuring with reference thermocouple set **COMP** in the instrument menu to **YES**
- when using a thermostat (a compensation box or environment with constant temperature) set **CC** in the instrument menu to its temperature
- if the reference thermocouple is located in the same environment as the measuring instrument then set **CC** in the instrument menu to number 99. Based on this selection the measurement of the surrounding temperature is performed by a sensor located in the instrument terminal board.

### WITHOUT REFERENCE THERMOCOUPLE

- inaccuracy originating from the creation of dissimilar thermocouples on the transition point terminal-conductor of the thermocouple is not compensated for in the instrument
- when measuring without reference thermocouple set **COMP** in the instrument menu to **NO**
- when measuring temperature without reference thermocouple the error in measured data maybe even 10 °C



## 8. DATA PROTOCOL

The instruments communicate via serial line RS232 or RS485. For communication they use the ASCII protocol. The communication is running in the following format:

ASCII: 8 bit, no parity, one stop bit

Transmission rate is adjustable in the instrument menu and depends on the used control processor. The instrument address is set in the instrument menu in the range of 0...31. Manufacture setting always presets the ASCII protocol, rate of 9600 Baud, address 00. Type of line used - RS232 / RS485 - is determined by exchangeable card automatically identified by the instrument.

### COMMANDS FOR INSTRUMENT OPERATION

The commands are described in the description which can be found at [www.orbit.merret.cz/rs](http://www.orbit.merret.cz/rs).

The command consists of a couple number-letter, where the letter size is of importance.

Symbol	Meaning	Symbol	Meaning
⊕	Send unit value	Ⓒ	Complete number
⊕	Set unit value	⒱	Selection = complete number
■	Perform relevant action	Ⓓ	Decimal number
		Ⓓ	Text - printable ASCII characters
		Ⓗ	Intel HEX format

### DETAIL DESCRIPTION OF COMMUNICATION VIA SERIAL LINE

Activity	Type	Protocol	Data transferred														
Data solicitation (PC)	232	ASCII	#	A	A	<CR>											
	485	ASCII	#	A	A	<CR>											
Data transfer (Instrument)	232	ASCII	>	D	D	D	D	D	D	D	(D)	(D)	(D)	<CR>			
	485	ASCII	>	D	D	D	D	D	D	D	(D)	(D)	(D)	<CR>			
Command transfer (Instrument)	232	ASCII	#	A	A	N	P	D	D	D	D	(D)	(D)	(D)	<CR>		
	485	ASCII	#	A	A	N	P	D	D	D	D	(D)	(D)	(D)	<CR>		
Command confirmation (Instrument)	232	ASCII	ok	!	A	A	<CR>										
			bad	?	A	A	<CR>										
	485	ASCII	ok	!	A	A	<CR>										
			bad	?	A	A	<CR>										

## 9. ERROR STATEMENTS

<b>ERROR</b>	<b>REASON</b>	<b>ELIMINATION</b>
<i>E. Und.</i>	range underflow (A/D converter)	change the input signal value or change display projection
<i>E. OueR.</i>	range overflow (A/D converter)	change the input signal value or change display projection
<i>E. nAt</i>	mathematic error, range of projection is out of display	change the set projection
<i>E.dAtAE</i>	violation of data integrity in EEPROM, error upon data storage	in case of recurring report send the instrument for repair
<i>E. nEn.</i>	EEPROM error	the „Def“ values will be used in emergency, instrument needs to be sent for repair
<i>E.CAL Ib</i>	calibration error, loss of calibration data	instrument needs to be sent for repair

## 10. INSTRUMENT DIMENSIONS AND INSTAL.

**Front view**

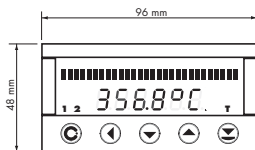

**Panel cut**

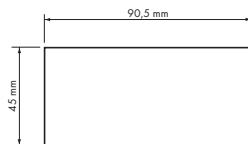

**Side view**

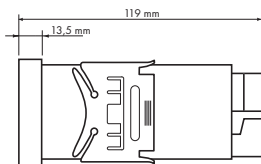

Panel thickness: 0,5...20 mm

### Instrument installation

1. insert the instrument into the panel cut-out
2. fit both travellers on the box
3. press the travellers close to the panel

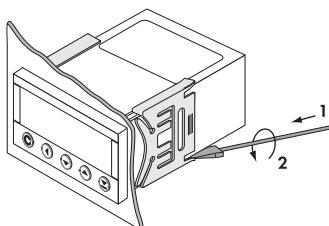
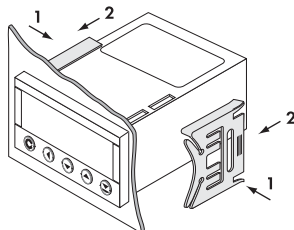

### Instrument disassembly

1. slide a screw driver under the traveller wing
2. turn the screw driver and remove the traveller
3. take the instrument out of the panel

# 11. TECHNICAL DATA

## INPUT

selectable in configuration menu

0...4 V	1 MOhm	DC	Input 2
0...40 V	1 MOhm		Input 2
0...400 V	1 MOhm		Input 2
0...60 mV	1 MOhm		Input 1
0...150 mV	1 MOhm		Input 1
0...300 mV	1 MOhm		Input 1

0...400 mA	< 60 mV		Input 2
0...1 A	< 60 mV		Input 1
0...5 A	< 60 mV		Input 1

selectable in configuration menu

0/4...20 mA	< 400 mV	PM	Input I
0...2 V	1 MOhm		Input U
0...5 V	1 MOhm		Input U
0...10 V	1 MOhm		Input U

selectable in configuration menu

0...400 Ohm		OHM	Input 1
0...4 Ohm			Input 1
0...40 kOhm			Input 1
5...105 Ohm			Input 2
0...100,0 kOhm	(upon request)		Input 2

Connection:

2 wire

Pt xxxx

-99,9°...399,9°C

Ni xxxx

-30,0°...250,0°C

Type Pt:

100/500/1 000 Ohm, platinum couple  
s  $\alpha = 0,00385 \text{ Ohm/Ohm/}^\circ\text{C}$ 

Type Ni:

Ni 1 000/2 226/10 000, 5000 ppm/6180 ppm

Connection:

2, 3 or 4 wire

selectable in configuration menu

Type:	J (Fe-CuNi)	0°...900°C	T/C
	K (NiCr-Ni)	0°...1 300°C	
	T (Cu-CuNi)	0°...400°C	
	E (NiCr-CuNi)	0°...690°C	
	B (PtRh30-PtRh6)	300°...1 820°C	
	S (PtRh10-Pt)	0°...1 760°C	
	R (Pt13Rh-Pt)	0°...1 740°C	
	N (Omegalloy)	0°...1 300°C	

- The instrument evaluates only temperatures higher than the temperature of the cold junction (C J)

## DU

Lin. pot.supply

2,5 VDC/6 mA

min. potentiometer resistance is 500 Ohm

## PROJECTION

Bargraph

30 LED - tricolours

Display, 6 digit intensive red or green LED,  
digit height 9 mm

Projection:

-999...3999

Decimal point:

adjustable - in programming mode

BRIGHT.:

adjustable - in programming mode

## INSTRUMENT ACCURACY

Temperature coef.: 100 ppm/°C

Accuracy:  $\pm 0,15\%$  of the range **DC/PM/DU**  
 $\pm 0,25\%$  of the range (for 60/150/300 mV) **DC**  
 $\pm 0,5\%$  of the range **A C**  
 $\pm 0,2\%$  of the range **OHM/RTD/TC**

Resolution: 0,1° **RTD**  
 1°C **T/C**

Rate: 1,3 - 2,5 - 5 - 10 - 20 - 40 measurements/s

Overload capacity: 10x ( $t < 100$  ms), 2x (long-term)  
 adjustable in configuration menu

Comp. of conduct: max. 40 Ohm **RTD**  
 Comp. of cold junct.: adjustable **T/C**

0°...98°C or automatic (99)

Functions:

Tare - display resetting  
 Hold - stop measuring (upon contact)  
 Projection of measured units

Watch-dog:

reset after 1,2 s

Calibration:

at 25°C and 40 % r.h.

## COMPARATOR

Type: digital, adjustable in the menu

Limits: -999...3999

Hysteresis: 0...999

Delay: 0...99,9 s

Outputs: 2x relays with switch-on contact  
 (230 VAC/30 VDC, 3 A)\*

Relay: 1/8 HP 277 VAC, 1/10 HP 125 V, Pilot Duty D300

## DATA OUTPUTS

Protocols: ASCII

Data format: 8 bit + no parity + 1 stop bit (ASCII)

Rate: 150...115 200 Baud

RS 232: isolated, two-way communication

RS 485: isolated, two-way communication,  
 addressing (max. 31 instruments)

**ANALOG OUTPUTS**

Type:	isolated, programmable with resolution of max. 10 000 points, analog output corresponds with the displayed data, type and range are adjustable
Non-linearity:	0,2% of the range
TC:	100 ppm/°C
Rate:	response to change of value < 100 ms
Voltage:	0...2 V/5 V/10 V
Current:	0...5/20 mA/4...20 mA - compensation of conduct up to 600 Ohm

**EXCITATION****PM**

Adjustable: 2...24 VDC/50 mA, isolated

**POWER SUPPLY**

Options:	24/110/230 VAC, 50/60 Hz, ±10%, 5 VA 10...30 VDC/max. 300 mA, isolated
Protection:	by a fuse inside the instrument VAC (T 80 mA), VDC (T 630 mA)

**MECHANIC PROPERTIES**

Material:	Noryl GFN2 SE1, incombustible UL 94 V-I
Dimensions:	96 x 48 x 120 mm
Panel cut-out:	90,5 x 45 mm

**OPERATING CONDITIONS**

Connection:	connector terminal board, conductor section up to 2,5 mm <sup>2</sup>
Stabilisation period:	within 15 minutes after switch-on
Working temp.:	0°...60°C
Storage temp.:	-10°...85°C
Cover:	IP65 (front panel only)
Construction:	safety class I
Overvoltage cat.:	EN 61010-1, A2 III. - instrument power supply (300 V) II. - input, output, excitation (300 V) for pollution degree II
EMC:	EN 61000-3-2+A12; EN 61000-4-2, 3, 4, 5, 8, 11; EN 550222, A1, A2

## 12. DECLARATION OF CONFORMITY

Company: ORBIT MERRET, spol.s r.o. (Ltd.)  
 Klánova 81/141  
 142 00 Prague 4  
 Czech Republic  
 IDNo: 00551309

Manufactured: ORBIT MERRET, spol.s r.o. (Ltd.)  
 Vodňanská 675/30  
 198 00 Prague 9  
 Czech Republic

declares at its full responsibility that the product presented hereunder meets all technical requirements, is safe for use when utilised under the terms and conditions determined by ORBIT MERRET, spol.s r.o. and that our company has taken all measures to ensure conformity of all products of the type listed hereunder, which are being brought out to the market, with technical documentation and requirements of the appurtenant statutory orders.

Product: Programmable Bargraph

Type: OMB 301, in versions: DC, PM, DU, PWR, OHM, RTD, T/C

Mode of asses. of conformity: § 12, par. 4 b, d of Act No.22/1997 Sb.

Conformity is assessed pursuant to the following standards:

Electrical safety: EN 61010-1  
 EMC: EN 50131-1, par. 14 and par. 15  
 EN 55022  
 EN 61000-3-2 + A12, Cor. 1, change A1, change A2  
 EN 61000-4-2  
 EN 61000-4-3  
 EN 61000-4-4  
 EN 61000-4-5  
 EN 61000-4-6  
 EN 61000-4-8  
 EN 61000-4-11

and government ordinance:

Electrical safety: No. 168/1997 Sb.  
 EMC: No. 169/1997 Sb.

The evidence are the protocols of authorized and accredited organization:

VTÚE Praha, experimental laboratory No. 1158 accredited by ČIA, o.p.s. with EN ISO/IEC 17025

Place and date of issue: Prague, 21. november 2001

Miroslav Hackl  
 Company representative

## 13. CERTIFICATE OF GUARANTEE

Product **OMB 301 DC PWR PM DU RTD T/C OHM**  
 Type .....  
 Manufacturing No. ....  
 Date of sale .....

A guarantee period of 24 months from the date of sale to the user applies to this instrument.

Defects occurring during this period due to manufacture error or due to material faults shall be eliminated free of charge.

For instrument quality, function and construction the guarantee shall apply provided that the instrument was connected and used in compliance with the instruction for use.

The guarantee shall not apply for defects caused by:

- mechanic damage
- in transport
- intervention of unqualified person incl. the user
- unavoidable event
- other unprofessional interventions

The manufacturer performs the guarantee and post-guarantee repairs unless provided for otherwise.

Stamp, signature

**ORBIT MERRET, spol. s r.o.**

Vodnanska 675/30  
198 00 Prague 9  
Czech Republic  
tel: +420 - 281 040 200  
fax: +420 - 281 040 299  
e-mail: orbit@merret.cz  
www.orbit.merret.cz

---

**Austria**

ING.E.GRUBER GmbH  
Edu. Kittenberger Gasse 97 Top2  
A-1230 Wien  
tel: +43 - 1 - 869 23 39-0  
fax: +43 - 1 - 865 18 75  
e-mail: office@gruber-components.at  
www.gruber-components.at

**The Netherlands**

AE SENSORS B.V.  
J. Valsterweg 92  
3301 AB Dordrecht  
tel: +31 - 78 - 621 31 52  
fax: +31 - 78 - 621 31 46  
e-mail: aesensors@aesensors.nl  
www.aesensors.nl

**Slovakia**

TECHREG, s.r.o.  
Dukelských hrdinov 2  
984 22 Lučenec  
tel: +421 - 47 - 433 15 92  
fax: +421 - 47 - 433 15 92  
e-mail: techreg@bb.psg.sk  
www.techreg.sk

**Ukraine**

OOO <KOTRIS>  
Nesterova 3, Office 907  
030 57 Kyjev  
tel: +44 - 446 - 21 42  
fax: +44 - 446 - 21 42  
e-mail: metrix-ua@svitonline.com

**Germany**

MEGATRON Elektronik AG & Co.  
Hermann-Oberth-Str. 7  
85640 Putzbrunn/München  
tel: +49 - 89 - 460 94 - 0  
fax: +49 - 89 - 460 941 01  
e-mail: sales@megatron.de  
www.megatron.de

**Russian Federation**

PO <INTERFACE>  
a.b. 3408  
Krasnodar, 350044  
tel: +1 - 8612 - 660 483  
fax: +1 - 8612 - 623 000  
e-mail: iff@au.ru  
www.meter.chat.ru

**Switzerland**

ORBIT CONTROLS AG  
Zürcherstrasse 137  
8952 Schlieren  
tel: +41 - 1 - 730 27 53  
fax: +41 - 1 - 730 27 83  
e-mail: info@orbitcontrols.ch  
www.orbitcontrols.ch

**USA**

METRIX Instruments Co.  
1711 Townhurst Dr.  
Houston, Texas 77043-2899  
tel: +1 - 713 - 461 21 31  
fax: +1 - 713 - 461 82 83  
e-mail: sales@metrix1.com  
www.metrix1.com

**Lithuania**

RIFAS UAB  
Tinklų g. 29a  
LT-5300 Panevėžys  
tel: +370 - 5 - 510 400  
fax: +370 - 5 - 582 729  
e-mail: sales@metrix1.com  
www.metrix1.com

**Russian Federation**

ZAO <ROSPRIBOR>  
Tamozhennyi proezd, dom 12,  
office 2-15  
Moscow, 111033  
tel: +1 - 95 - 36 29 446  
fax: +1 - 95 - 36 29 177  
e-mail: sales@rospribor.com  
www.rospribor.com

**Turkey**

ALFA ELEKTRONIK Ltd.  
Baglarbasi Mah. Ergenekon No: 33  
TR - 81540 Maltepe - ISTANBUL  
tel: +90 - 216 - 442 39 49  
fax: +90 - 219 - 305 54 50  
e-mail: sb@elmak.com.tr  
www.alfa-technik.com