

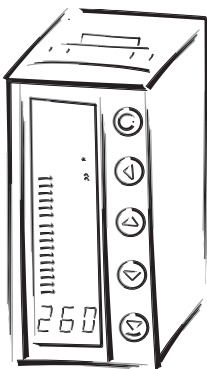

OMB 412UNI

4 DIGIT PROGRAMMABLE UNIVERSAL BARGRAPH

DC VOLTMETER / AMMETER
PROCESS MONITOR
OHMMETER
THERMOMETER FOR PT 100 / 500 / 1 000
THERMOMETER FOR NI 1 000
THERMOMETER FOR THERMOCOUPLES
DISPLAYS FOR LIN. POTENTIOMETERS



SAFETY INSTRUCTIONS

Please, read the enclosed safety instructions carefully and observe them!
These instruments should be safeguarded by isolated or common fuses (breakers)!
For safety information the EN 61 010-1 + A2 standard must be observed.
This instrument is not explosion-safe!

TECHNICAL DATA

Measuring instruments of the OMB 412 series conform to the European regulation 89/336/EWG and the Ordinance 168/1997 Coll.

The instruments are up to the following European standards:
EN 55 022, class B
EN 61000-4-2, -4, -5, -6, -8, -9, -10, -11

The instruments are applicable for unlimited use in agricultural and industrial areas.

CONNECTION

Supply of energy from the main line has to be isolated from the measuring leads.



ORBIT MERRET, spol. s r.o.

Vodnanska 675/30
198 00 Prague 9
Czech Republic

Tel: +420 - 281 040 200
Fax: +420 - 281 040 299
e-mail: orbit@merret.cz
www.orbit.merret.cz



1.	Contents	3
2.	Instrument description	4
3.	Instrument connection	6
4.	Instrument setting	8
	Symbols used in the instructions	10
	Setting the DP and the (-) sign	10
	Control keys function	11
	Setting/permitting items into "USER" menu	11
5.	Setting "LIGHT" menu	12
5.0	Description "LIGHT" menu	12
	Setting input - Type "DC"	16
	Setting input - Type "PM"	18
	Setting input - Type "DU"	20
	Setting input - Type "OHM"	22
	Setting input - Type "RTD - Pt"	24
	Setting input - Type "RTD - Ni"	26
	Setting input - Type "T/C"	28
	Setting Limits	30
	Setting analog output	32
	Setting of bargraph	34
	Selection of programming menu „LIGHT"/„PROFI"	36
	Restoration of manufacture setting	36
	Calibration - input range (DU)	37
	Selection of instrument menu language version	38
	Setting new access password	38
	Instrument identification	39
6.	Setting "PROFI" menu	40
6.0	Description of "PROFI" menu	40
6.1	"PROFI" menu - INPUT	
6.1.1	Resetting internal values	42
6.1.2	Setting measuring type, range, mode, rate,	43
6.1.3	Setting the Real Time	49
6.1.4	External input function selection	49
6.1.5	Optional accessory functions of the keys	50
6.2	"PROFI" menu - CHANNEL	
6.2.1	Setting measuring parameters (projection, filters, decimal point, description)	54
6.2.2	Setting mathematic functions	57
6.2.3	Selection of evaluation of min/max. value	59
6.3	"PROFI" menu - OUTPUT	
6.3.1	Setting data logging	60
6.3.2	Setting Limits	62
6.3.3	Setting data output	64
6.3.4	Setting analog output	65
6.3.5	Selection of display projection	67
6.3.6	Selection of bargraph projection	68
6.4	"PROFI" menu - SERVICE	
6.4.1	Selection of programming menu „LIGHT"/„PROFI"	72
6.4.2	Restoration manufacture setting	73
6.4.3	Calibration - input range (DU)	74
6.4.4	Selection of instrument menu language version	74
6.4.5	Setting new access password	74
6.4.6	Instrument identification	75
7.	Setting items into "USER" menu	78
7.0	Configuration "USER" menu	78
8.	Method of measuring of the cold junction	80
9.	Data protocol	81
10.	Error statements	82
11.	Technical data	84
12.	Instrument dimensions and instalation	86
13.	Certificate of guarantee	87
	Declaration of conformity	88

2.1 Description

The OMB 402 model series are 24 LED, 3-colour panel programmable vertical bargraph designed for maximum efficiency and user comfort while maintaining their favourable price.

Type OMB 402UNI is a multifunction bargraph with the option of configuration for 7 various input options, easily configurable in the instrument menu. By further options of input modules it is feasible to measure larger ranges of DC voltage and current or increase the number of inputs up to 4 (applies for PM).

The instrument is based on an 8-bit microcontroller with a multichannel 24-bit sigma-delta converter, which secures high accuracy, stability and easy operation of the instrument.

The OMB 412 is a multifunction instrument available in following types and ranges

type UNI

DC:	0...60/150/300/1200 mV
PM:	0...5 mA/0...20 mA/4...20 mA/±2 V/±5 V/±10 V/±40 V
OHM:	0...100 Ω/0...1 kΩ/0...10 kΩ/0...100 kΩ
RTD-Pt:	Pt 100/Pt 500/Pt 1000
RTD-Ni:	Ni 1 000/Ni 10 000
T/C:	J/K/T/E/B/S/R/N
DU:	Linear potentiometer (min. 500 Ω)

type UNI, option A

DC:	0...1 A/0...5 A/±30 V/±120 V/±500 V
------------	-------------------------------------

type UNI, option B (expansion by 3 more inputs)

PM:	3x 0...5 mA/0...20 mA/4...20 mA/±2 V/±5 V/±10 V/±40 V
------------	---

PROGRAMMABLE PROJECTION

Selection:	of type of input and measuring range
Measuring range:	adjustable as fixed or with automatic change
Setting:	manual, optional projection on the display may be set in the menu for both limit values of the input signal, e.g. input 0...20 mA > 0...850,0
Projection:	24-segment LED 3-color bargraph + 3-digit display -99...999

COMPENSATION

of conduct:	in the menu it is possible to perform compensation for 2-wire connection
of conduct in probe:	internal connection (conduct resistance in measuring head)
of CJC (T/C):	manual or automatic, in the menu it is possible to perform selection of the type of thermocouple and compensation of cold junctions, which is adjustable or automatic (temperature at the brackets)

LINEARIZATION

Linearization:*	by linear interpolation in 50 points (solely via OM Link)
-----------------	---

DIGITAL FILTERS

Exponen.average:	from 2...100 measurements
Rounding:	setting the projection step for display

MATHEMATIC FUCTIONS

Min/max. value:	registration of min./max. value reached during measurement
Tare:	designed to reset display upon non-zero input signal
Peak value:	the display shows only max. or min. value
Mat. operations:	polynome, 1/x, logarithm, exponential, power, root, sin x

EXTERNAL CONTROL

Lock:	control keys blocking
Hold:	display/instrument blocking
Tare:	tare activation/resetting tare to zero
Resetting MM:	resetting min/max value
Memory:	data storage into instrument memory

2.2 Operation

The instrument is set and controlled by five control keys located on the front panel. All programmable settings of the instrument are performed in three adjusting modes:

LIGHT	Simple programming menu - contains solely items necessary for instrument setting and is protected by optional number code
PROFI	Complete programming menu - contains complete instrument menu and is protected by optional number code
USER	User programming menu - may contain arbitrary items selected from the programming menu (LIGHT/PROFI), which determine the right (see or change) - access without password

All programmable parameters are stored in the EEPROM memory (they hold even after the instrument is switched off).

OMLINK Complete instrument operation and setting may be performed via OM Link communication interface, which is a standard equipment of all instruments.

The operation program is freely accessible (www.orbit.merret.cz) and the only requirement is the purchase of OML cable to connect the instrument to PC. It is manufactured in version RS 232 and USB and is compatible with all ORBIT MERRET instruments. Another option for connection is with the aid of data output RS 232 or RS 485 (without the need of the OML cable).

The program OM LINK in „Basic“ version will enable you to connect one instrument with the option of visualization and archiving in PC. The OM Link „Standard“ version has no limitation of the number of instruments connected.

2.3 Options

Excitation is suitable for supplying power to sensors and transmitters. It has a galvanic separation.

Comparators are assigned to monitor one, two, three or four limit values with relay output. The user may select limits regime: LIMIT/DOSING/FROM-TO. The limits have adjustable hysteresis within the full range of the display as well as selectable delay of the switch-on in the range of 0...99,9 s. Reaching the preset limits is signalled by LED and simultaneously by the switch-on of the relevant relay.

Data outputs are for their rate and accuracy suitable for transmission of the measured data for further projection or directly into the control systems. We offer an isolated RS232 and RS485 with the ASCII or DIN MessBus protocol.

Analog outputs will find their place in applications where further evaluating or processing of measured data is required in external devices. We offer universal analog output with the option of selection of the type of output - voltage/current. The value of analog output corresponds with the displayed data and its type and range are selectable in Menu.

Measured data record is an internal time control of data collection. It is suitable where it is necessary to register measured values. Two modes may be used. FAST is designed for fast storage (40 records/s) of all measured values up to 8 000 records. Second mode is RTC, where data record is governed by Real Time with data storage in a selected time segment and cycle. Up to 250 000 values may be stored in the instrument memory. Data transmission into PC via serial interface RS232/485 and OM link.

The instrument supply leads should not be in proximity of the incoming low-potential signals.

Contactors, motors with larger input power should not be in proximity of the instrument.

The leads into the instrument input (measured quantity) should be in sufficient distance from all power leads and appliances. Provided this cannot be secured it is necessary to use shielded leads with connection to ground (bracket E).

The instruments are tested in compliance with standards for use in industrial area, yet we recommend to abide by the above mentioned principles.

MEASURING RANGES

Type	Input I	Input U
DC	0...60/150/300/1 200 mV	
PM	0...5/20 mA/4...20 mA	$\pm 2/\pm 5/\pm 10/\pm 40$ V
OHM	0...0,1/1/10/100 k Ω	
RTD-Pt	Pt 100/Pt 500/ Pt 1 000	
RTD-Ni	Ni 1 000/10 000	
T/C	J/K/T/E/B/S/R/N	
DU	Linear potentiometer (min. 500 Ω)	

OPTION "A"

Type	Input I	Input U
DC	0...1/5 A	± 120 V/ ± 250 V/ ± 500 V

OPTION "B"

Type	Input 2, 3, 4/I	Input 2, 3, 4/U
PM	0...5/20 mA/4...20 mA	$\pm 2/\pm 5/\pm 10/\pm 40$ V

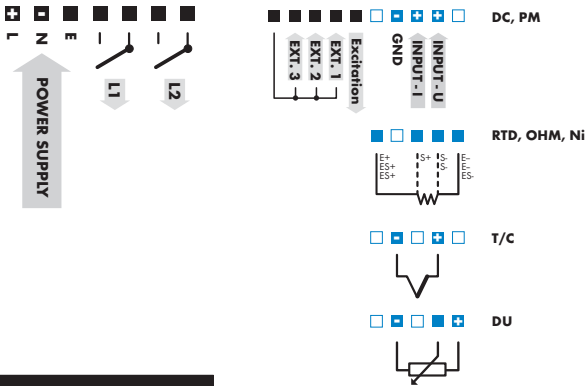
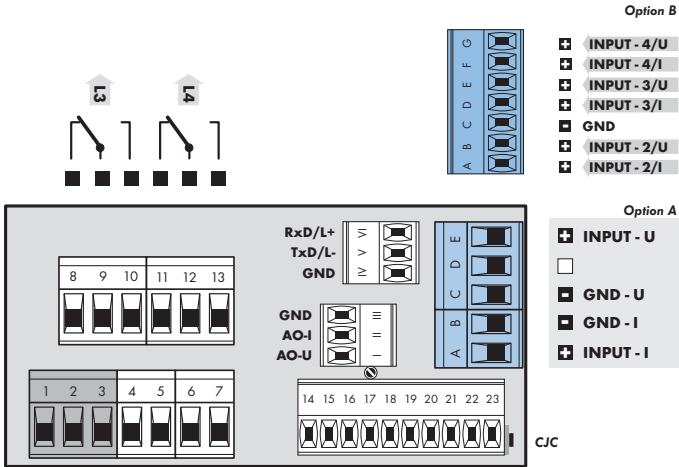

!
 Excitation has the minus pole common with the input - the bracket no. 20 - GND and you may set its value by trimmer above the bracket no. 17

PROFI

Setting

profi

- ▶ For expert users
- ▶ Complete instrument menu
- ▶ Access is password protected
- ▶ Possibility to arrange items of the „User“ menu
- ▶ Tree menu structure

LIGHT

Setting

light

- ▶ For trained users
- ▶ Only items necessary for instrument setting
- ▶ Access is password protected
- ▶ Possibility to arrange items of the „User“ menu
- ▶ Linear menu structure

USER

Setting

*profi light**user*

- ▶ For user operation
- ▶ Menu items are set by the user (Profi/Light) as per request
- ▶ Access is not password protected
- ▶ Optional menu structure either tree (PROFI) or linear (LIGHT)

4.1 Setting

The instrument is set and controlled by five control keys located on the front panel. All programmable settings of the instrument are performed in three adjusting modes:

- LIGHT** **Simple programming menu**
 - contains solely items necessary for instrument setting and is protected by optional number code
- PROFI** **Complete programming menu**
 - contains complete instrument menu and is protected by optional number code
- USER** **User programming menu**
 - may contain arbitrary items selected from the programming menu (LIGHT/PROFI), which determine the right (see or change)
 - access without password

All programmable parameters are stored in the EEPROM memory (they hold even after the instrument is switched off).

Complete instrument operation and setting may be performed via OM Link communication interface, which is a standard equipment of all instruments.

The operation program is freely accessible (www.orbit.merret.cz) and the only requirement is the purchase of OML cable to connect the instrument to PC. It is manufactured in version RS 232 and USB and is compatible with all ORBIT MERRET instruments.

Another option for connection is with the aid of data output RS 232 or RS 485 (without the need of the OML cable).

Scheme of processing the measured signal

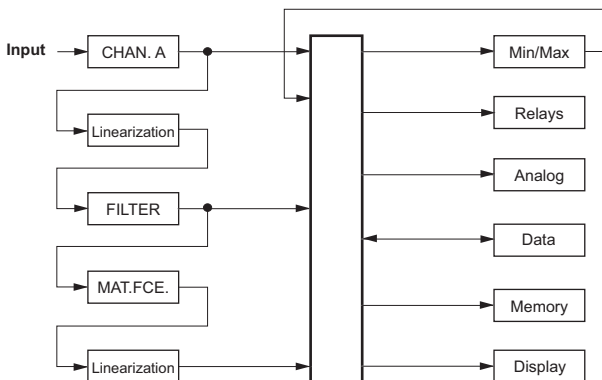

Setting and controlling the instrument is performed by means of 5 control keys located on the front panel. With the aid of these keys it is possible to browse through the operation menu and to select and set required values.

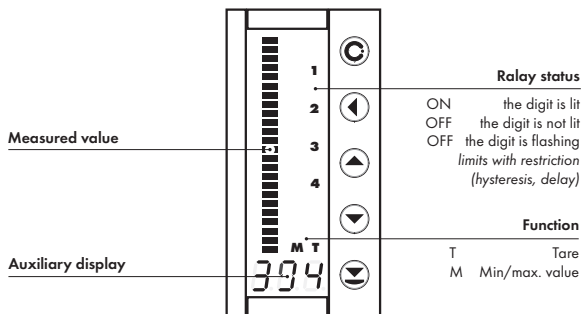

Symbols used in the instructions

DC **PM**

DU **OHM**

RTD **T/C**

Indicates the setting for given type of instrument

DEF

values preset from manufacture



symbol indicates a flashing light (symbol)



inverted triangle indicates the item that can be placed in USER menu



broken line indicates a dynamic item, i.e. it is displayed only in particular selection/version



after pressing the key the set value will not be stored



after pressing the key the set value will be stored



30 continues on page 30

Setting the decimal point and the minus sign

DECIMAL POINT

Its selection in the menu, upon modification of the number to be adjusted it is performed by the control key **1** with transition beyond the highest decade, when the decimal point starts flashing. Positioning is performed by **3**/**4**.

THE MINUS SIGN

Setting the minus sign is performed by the key **5** on higher decade. When editing the item subtraction must be made from the current number (e.g.: 013 > **5**, on class 100 > -87)

Control keys functions

Key	Measurement	Menu	Setting numbers/selection
	access into USER menu	exit menu	quit editing
	programmable key function	back to previous level	move to higher decade
	programmable key function	move to previous item	move down
	programmable key function	move to next item	move up
	programmable key function	confirm selection	confirm setting/selection
			numeric value is set to zero
	access into LIGHT/PROFI menu		
	direct access into PROFi menu		
		configuration of an item for "USER" menu	
		determine the sequence of items in "USER - LIGHT" menu	

Setting items into „USER“ menu

- in LIGHT or PROFi menu
- no items permitted in USER menu from manufacture
- on items marked by inverted triangle

user

Legend is flashing - current setting is displayed



- item will not be displayed in USER menu
- item will be displayed in USER menu with the option of setting
- item will be solely displayed in USER menu

5.0

Setting "LIGHT"

LIGHT**Simple programming menu**

- contains only items necessary for instrument setting and is protected by optional number code

SETTING LIGHT

Light

- For capable users
- Only items necessary for instrument setting
- Access is password protected
- Possibility to arrange items of the „User“ menu
- Linear menu structure

Preset from manufacture

Password	"0"
Menu	LIGHT
USER menu	off
Setting the items	DEF

142



PAS

0

Access password

!
Upon delay exceeding 60 s the programming mode is automatically discontinued and the instrument itself restores the measuring mode

typ

dC

NOd

60

Selecting input and range

RTD OHM

CO_n

2-u

FO_n

000

Selecting projection and connection

TC

CO_n

EM1

t.C.U.

23

FO_n

000

DC PM OHM DU

nIn

0

NAH

100

FO_n

000

L1

20

L2

40

Option - comparator

L3

60

L4

80

Option - Analog output

typ

120

ALo

0

AH1

100

Setting bargraph projection

bLo

0

bH1

100

Setting bargraph colors

COL

GrE

Menu type

nIn

L10

Return to calibration setting

CR1

YES

Return to manufacture setting

SEt

YES

DU

CLo

YES

CH1

YES

Calibration - only for "DU"

Language selection

LAn

EnU

New password

n.PA

0

Identification

id

YES

006 412...

142

Return to measuring mode

1428



PAS

0

Entering access password
for access into the menu

PAS Access into instrument menu

PAS = 0

- access into menu is unrestricted, after releasing keys you automatically move to first item of the menu

PAS > 0

- access into menu is protected by number code

Set "Password" = 42 Example

0 7 3 2 02 12 22

32 42 43P

43P

dc Pn OHM Pt Ni tC

du

43P Selection of the type of instrument

- primary selection of the type of instrument
- performs default setting **DEF** of values from manufacture, incl. calibration

Menu	Type of instrument
DC	DC voltmeter
PM	Process monitor
OHM	Ohmmeter
Pt	Thermometer for sensors Pt
Ni	Thermometer for sensors Ni
TC	Thermometer for thermocouples
DU	Display for lin. potentiometer

Type "PM" Example

dc Pn 100d

Type „DC“	16
Type "PM"	18
Type "DU"	20
Type "OHM"	22
Type "RTD-Pt"	24
Type "RTD-Ni"	26
Type "T/C"	28

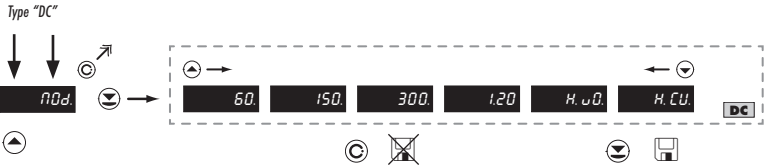

n0d. Selection of the instrument measuring range

DEF = 60 mV
DEF = H. VO.*

* only for option "A"

MOD.	Measuring range
60.	±60 mV
150.	±150 mV
300.	±300 mV
1.20	±1,2 V
H. VO.	±120 V/±250 V/±500 V*
H. CU.	0...1 A/ 0...5 A*

Range ±150 mV Example

60. 150. n In



n In Setting display projection for minimum value of input signal

- range of the setting is -99...999

- position of the DP does not affect display projection
- the DP is automatically shifted after the value is confirmed

DEF = 0

Projection for 0 mV > MIN = 0 Example

0 n In



100 Setting for maximum input signal

- position of the DP does not affect display projection
- the DP is automatically shifted after the value is confirmed

DEF = 100

Projection for 150 mV > MAX = 350 Example

100	100	110	120	130	140
150	150	250	350	F0r	

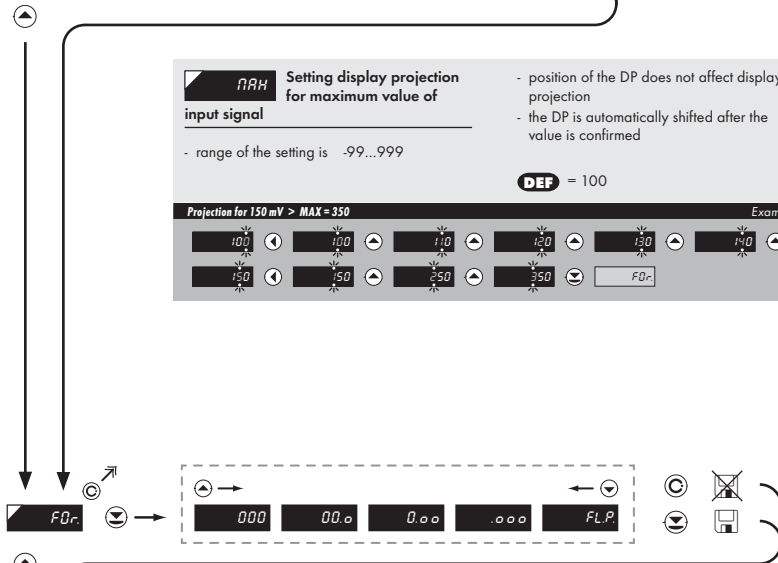

F0r Setting projection of the decimal point

- positioning of the DP is set here in the measuring mode

DEF = 000

Projection of DP on display > 00.0 Example

000	00.0	0.00	.000	FLP
-----	------	------	------	-----

**subsequent item on the menu depends on instrument equipment*

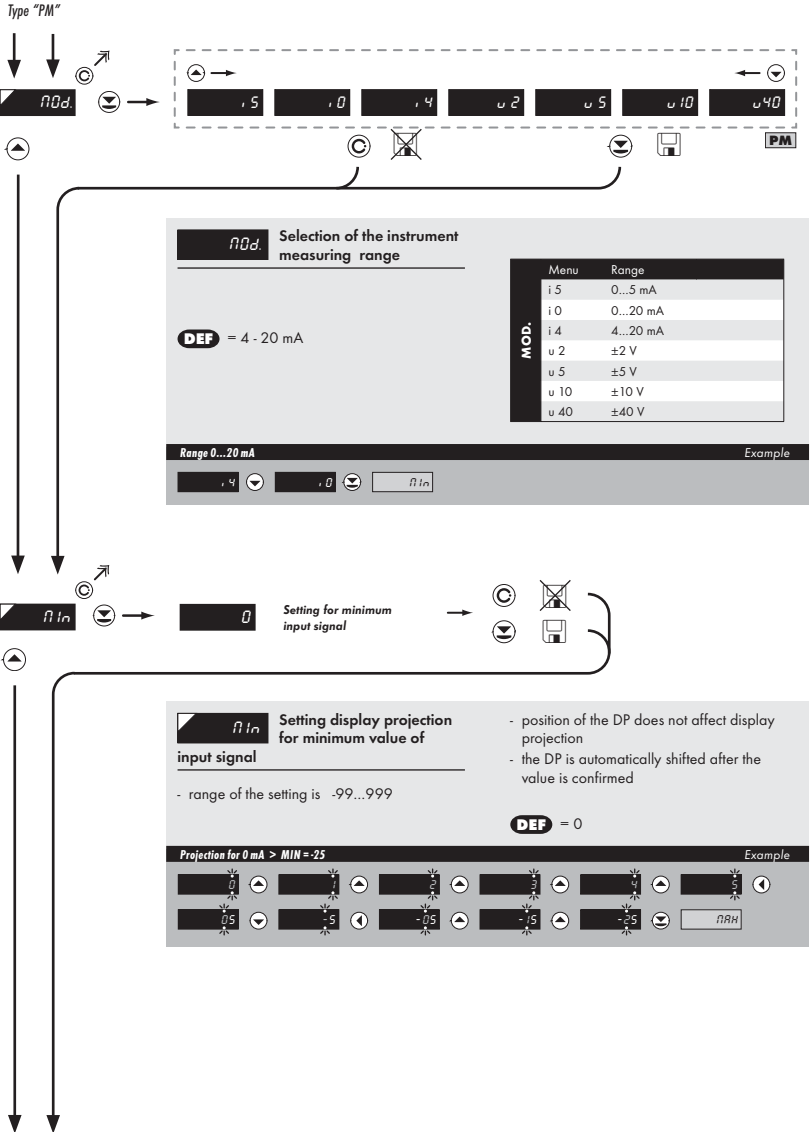



Setting for maximum input signal

MAX Setting display projection for maximum value of input signal

- position of the DP does not affect display projection
- the DP is automatically shifted after the value is confirmed

- range of the setting is -99...999

DEF = 100

Projection for 20 mA > MAX = 250 Example

100	110	120	130	140	150
150	160	170	180	190	F0.r



F0.r Setting projection of the decimal point

- positioning of the DP is set here in the measuring mode

DEF = 000

Projection of DP on display > 00.0 Example

000	00.0	0.00	FLP
-----	------	------	-----

* subsequent item on the menu depends on instrument equipment

Type "DU"

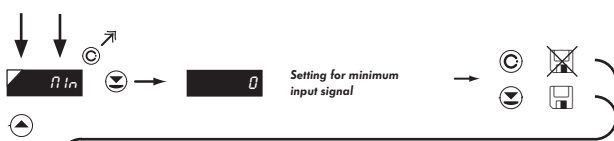

Setting display projection for minimum value of input signal

- range of the setting is -99...999

- position of the DP does not affect display projection
- the DP is automatically shifted after the value is confirmed

DEF = 0

Projection for the beginning > MIN = 0

Example



Setting display projection for maximum value of input signal

- range of the setting is -99...999

- position of the DP does not affect display projection
- the DP is automatically shifted after the value is confirmed

DEF = 100

Projection for the end > MAX = 500

Example





F0r	Setting projection of the decimal point	DEF = 000
- positioning of the DP is set here in the measuring mode		
Projection of DP on display > 000		<i>Example</i>
000	↕	0.00
* subsequent item on the menu depends on instrument equipment		



30

Calibration of the beginning and the end of range of linear potentiometer is on page 35





MAX Setting display projection for maximum value of input signal

- position of the DP does not affect display projection
 - the DP is automatically shifted after the value is confirmed

- range of the setting is -99...999

DEF = 100

Projection for 10 L0hm > MAX = 700 Example

100	100	00	100	500	500
100	10.0	0.00	.000	FLP	



FDr Setting projection of the decimal point

- positioning of the DP is set here in the measuring mode

DEF = 000

Projection of DP on display > 00.0 Example

000	00.0	0.00	0.00
000	00.0	0.00	0.00

* subsequent item on the menu depends on instrument equipment

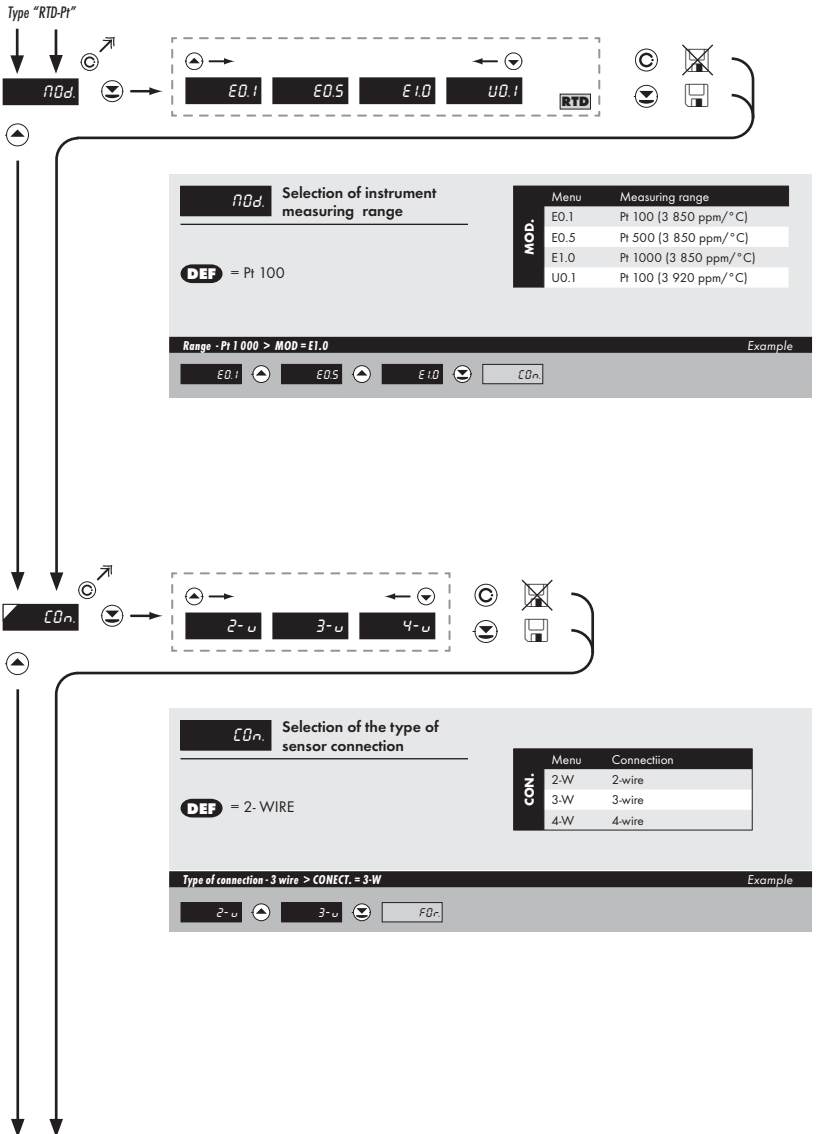



F0r. Setting projection of the decimal point **DEF** = 000

- positioning of the DP is set here in the measuring mode

Projection of DP on display > 00.0 *Example*

000

▲

00.0

▼

n.nU

* subsequent item on the menu depends on instrument equipment





RTD. Selection of instrument measuring range

DEF = Ni 1 000 - 5 000 ppm/°C

Menu	Measuring range
5-1	Ni 1 000 (5 000 ppm/°C)
6-1	Ni 1 000 (6 180 ppm/°C)
510	Ni 10 000 (5 000 ppm/°C)
610	Ni 10 000 (6 180 ppm/°C)

Range - Ni 10 000, 5 000 ppm > MOD = 510 Example

5-1 ◀ ▶ 6-1 ◀ ▶ 510 ◀ ▶



CON. Selection of the type of sensor connection

DEF = 2-WIRE

Menu	Connection
2-W	2-wire
3-W	3-wire
4-W	4-wire

Type of connection - 3 wire > CON. = 3-W Example

2-w ◀ ▶ 3-w ◀ ▶



F0r Setting projection of the decimal point **DEF** = 000

- positioning of the DP is set here in the measuring mode

Projection of DP on display > 00.0 *Example*

000
▲
00.0
▼
n.n.U
*subsequent item on the menu depends on instrument equipment



Type "T/C"

The diagram shows a sequence of menu screens and navigation steps:

- Initial Screen:** Type "T/C" is entered. The display shows **nDd.** with navigation arrows.
- Selection of the type of thermocouple:** A dashed box shows options: **b**, **E**, **J**, **F**, **n**, **r**, **S**, **t**. A **T/C** icon is also present.
- Selection of the type of sensor connection:** A dashed box shows options: **In.1**, **In.2**, **EH.1**, **EH.2**.

Selection of the type of thermocouple

Setting the input range depends on the measuring range ordered

DEF = Type "J"

Menu	Type of thermocouple
B	T/C B
E	T/C E
J	T/C J
K	T/C K
N	T/C N
R	T/C R
S	T/C S
T	T/C T

Type of thermocouple "K"

Example

J **F** **CO.n**

Selection of the type of sensor connection

DEF = EX. 1

Menu	Connection	Ref. T/C
IN.1	measuring C.J. at instrument brackets	×
IN.2	measuring C. J. at instrument brackets with anti-series connected ref. TC	✓
EX.1	the entire measuring set is working under invaried and constant temperature	×
EX.2	when using compensation box	✓

Type of connection > CON. = EX. 2

Example

EH.1 **EH.2** **CO.n**



t.C.J. Setting temperature of cold junction **DEF** = 23

- range 0...99 °C with compensation box

Setting temperature of cold junction > T.C.J. = 35 Example

23 24 25 25 35 F0r



F0r Setting projection of the decimal point **DEF** = 000

- positioning of the DP is set here in the measuring mode

Projection of DP on display > 00.0 Example

000 00.0 0.00 0.00 * subsequent item on the menu depends on instrument equipment

! For thermocouple type "B" the items CON. and t.C.J. are not available

! Method and procedure of setting the cold junctions is described in separate chapter on page 74

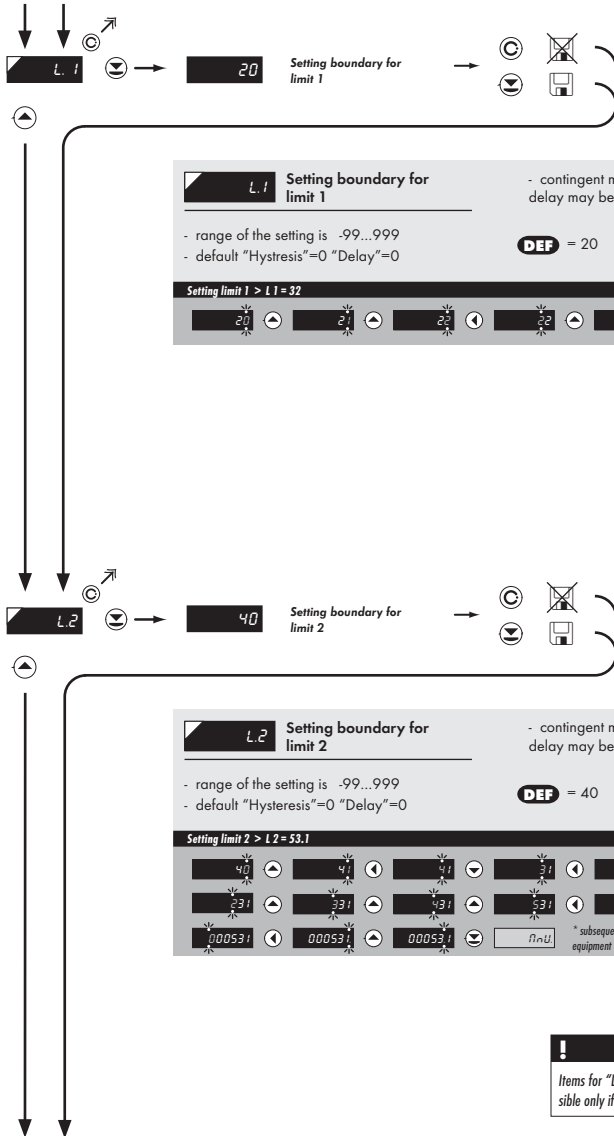

! Items for "Limits" and "Analog output" are accessible only if incorporated in the instrument.



L3 Setting boundary for limit 3

- range of the setting is -99...999
- default "Hysteresis"=0 "Delay"=0

DEF = 60

Setting limit 3 > L3 = 85 Example

80	61	62	63	64	65
65	75	85	nU		



L4 Setting boundary for limit 4

- range of the setting is -99...999
- default "Hysteresis"=0 "Delay"=0

DEF = 80

Setting limit 4 > L4 = 103 Example

80	81	82	83	83	93	93
03	03	03	nU			

* subsequent item on the menu depends on instrument equipment

TYP Setting the type of analog output

Menu	Range	Description
i.20	0...20 mA	
E.4	4...20 mA	with indication of error statement (<3,6 mA)
i.4	4...20 mA	
i.5	0...5 mA	
u.2	0...2 V	
u.5	0...5 V	
u.10	0...10 V	

DEF = 4...20 mA

Type of analog output - 0...10 V > TYP = U 10 Example

RLo Assigning the display value to the beginning of the AO range

DEF = 0

- range of the setting is -99...999

Display value for the beginning of the AO range > A.Lo. = 0 Example

!

Items for "Limits" and "Analog output" are accessible only if incorporated in the instrument.

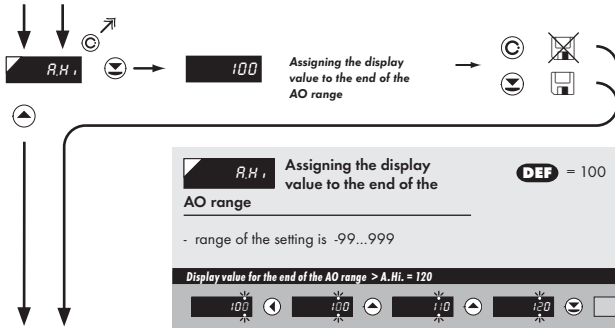

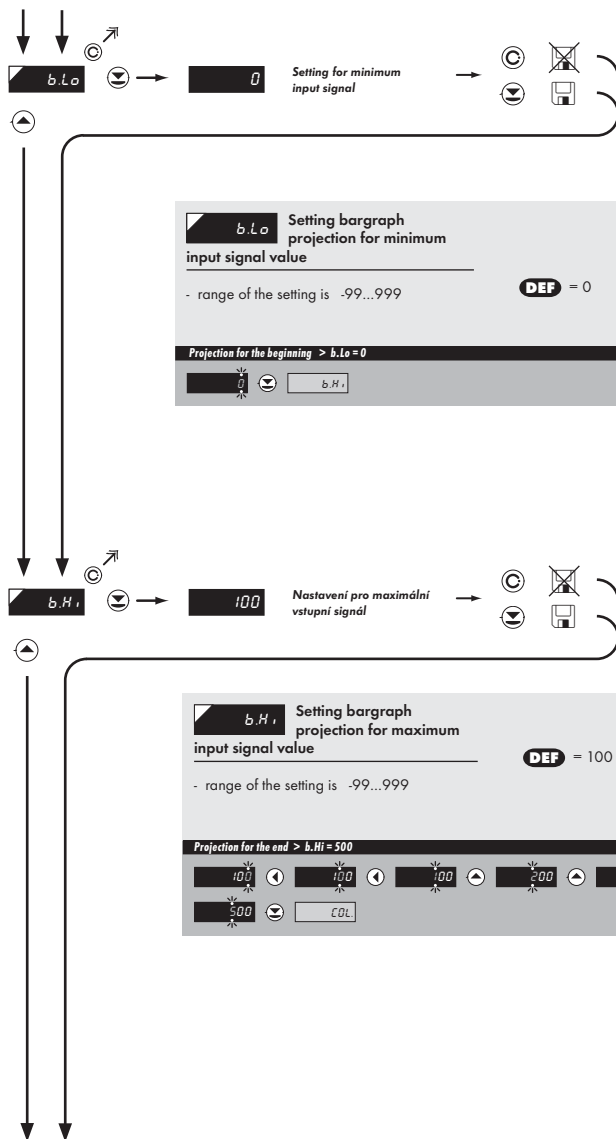



COL Select bargraph color

- the color for bargraph in basic mode
"Column" is set here

- for other bargraph working modes it is
necessary to switch to the "PROFI" menu

DEF = Green

Selection of bargraph color > Orange Example

GrE

▼

OrR

▼

NoU

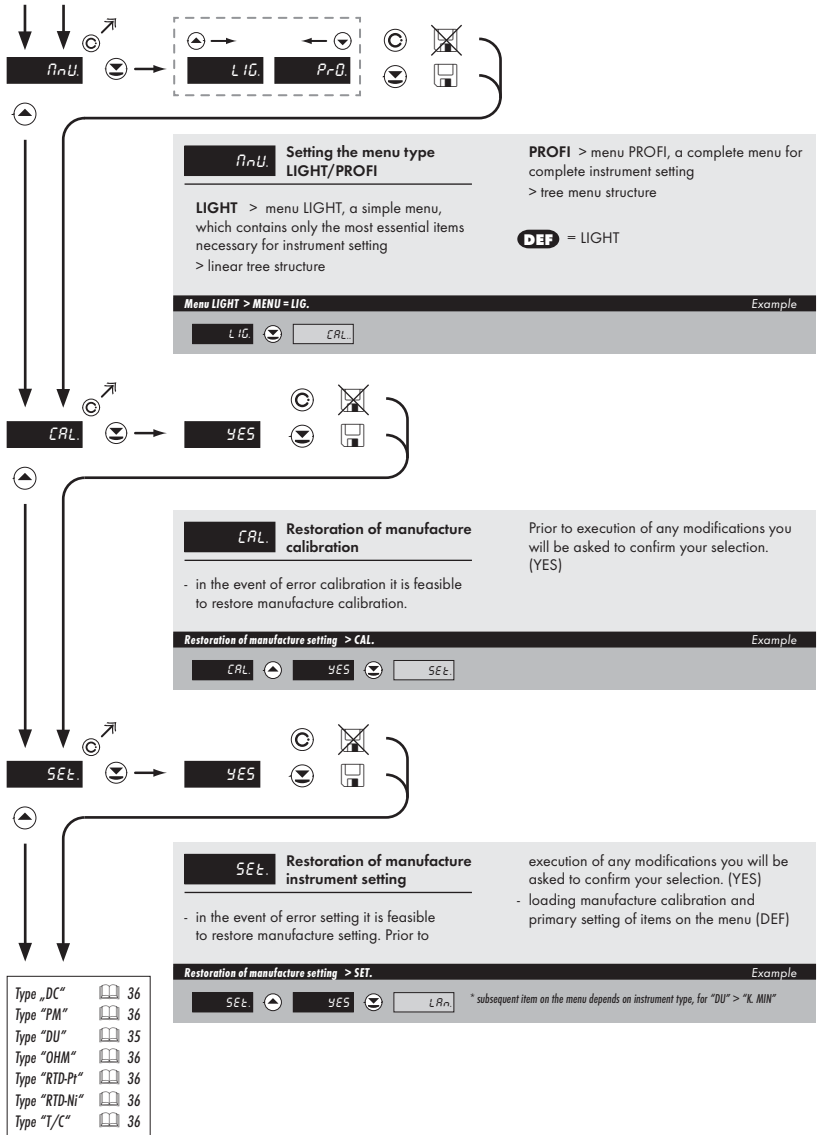

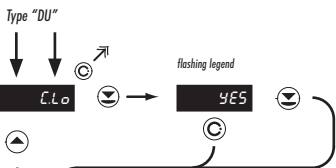

C.Lo Calibration of input range - the potentiometer traveller in initial position Only for type "DU"

- prior confirming the flashing "YES" sign the potentiometer traveller has to be in given idle position

Calibration of the beginning of the range > C.Lo Example

YES **C.Hi**

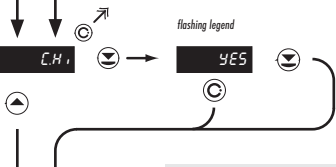

C.Hi Calibration of input range - the potentiometer traveller in end position Only for type "DU"

- prior confirming the flashing "YES" sign the potentiometer traveller has to be in given idle position

Calibration of the end of the range > C.Hi Example

YES **LRn**



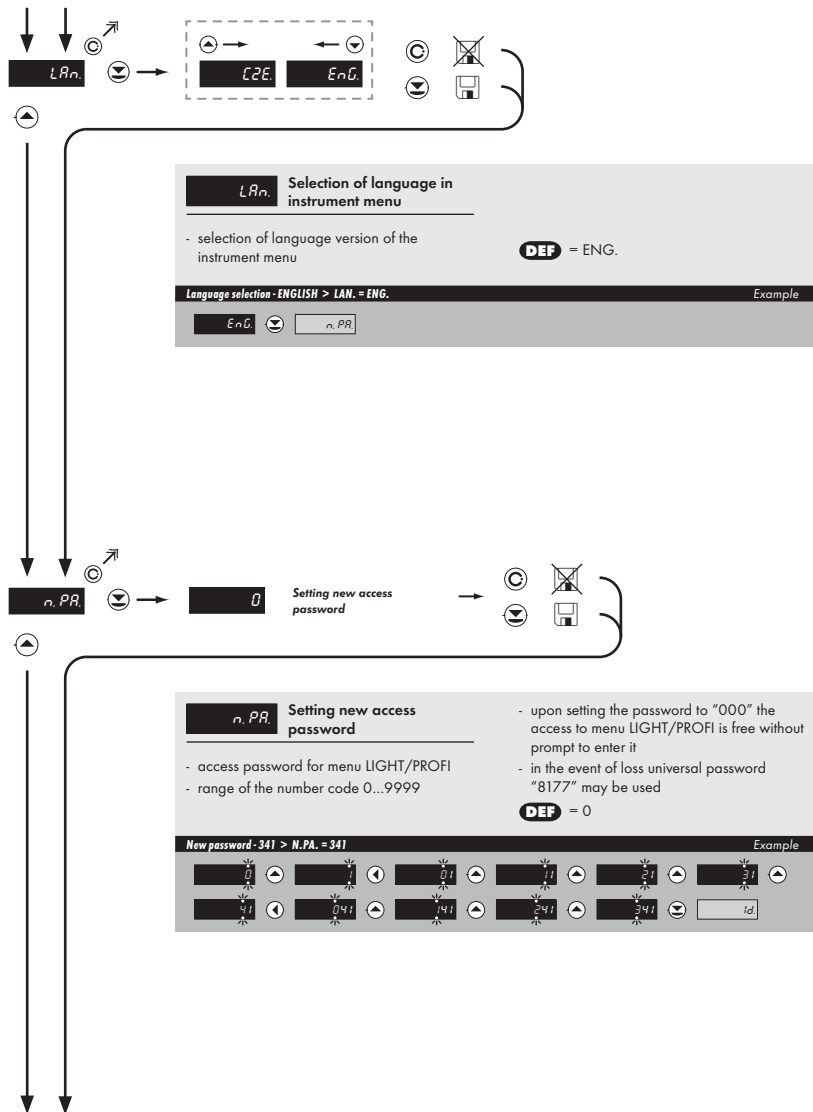

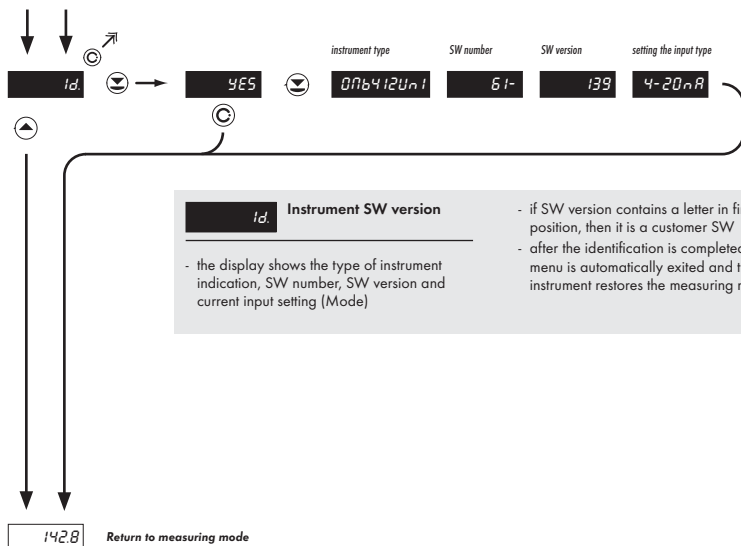

6.0

Setting "PROFI"

PROFI

Complete programming menu

- contains complete instrument menu and is protected by optional number code
- designed for expert users
- preset from manufacture is menu **LIGHT**

 SETTING
 PROFI
 

- For expert users
- Complete instrument menu
- Access is password protected
- Possibility to arrange items of the „User“ menu
- Tree menu structure

Switching over to "PROFI" menu



- temporary switch-over to **PROFI** menu, which is suitable to edit a few items
- after quitting **PROFI** menu the instrument automatically switches to **LIGHT** menu
- access is password protected (if it was not set under item N. PA. =0)



- access into **LIGHT** menu and transition to item „MNU“ with subsequent selection of „PROFI“ and confirmation
- after re-entering the menu the **PROFI** type is active
- access is password protected (if it was not set under item N. PA. =0)

6.1 Setting "PROFI" - INPUT

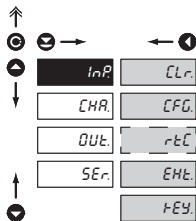

The primary instrument parameters are set in this menu

- Resetting internal values
- Selection of measuring range and parameters
- Setting date and time for option with RTC
- Setting external inputs functions
- Assigning further functions to keys on the instrument

6.1.1 Resetting internal values

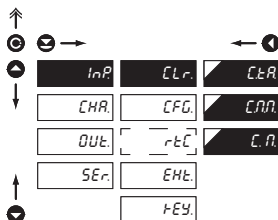

Resetting internal values

- Tare resetting
- Resetting min/max value

- resetting memory for the storage of minimum and maximum value achieved during measurement

- Resetting the instrument memory
- resetting memory with data measured in the "FAST" or "RTC" modes
- not in standard equipment

6.1.2a Selection of measuring rate

↑	⊖	→	←	1
⊕				
↓				
	InP	CLr	NPS	40.0
	CHR	CFG	LYP	20.0
	OUT	rEL	NOd	10.0
	SEr	EHL	EOr	5.0
		LEY	t.C.J	2.0
			rAd	1.0
			LER	0.5
				0.2
				0.1
↑				
⊖				

DEF

NPS Selection of measuring rate

40.0	40,0 measurements/s
20.0	20,0 measurements/s
10.0	10,0 measurements/s
5.0	5,0 measurements/s
2.0	2,0 measurements/s
1.0	1,0 measurement/s
0.5	0,5 measurements/s
0.2	0,2 measurements/s
0.1	0,1 measurements/s

6.1.2b Selection of „instrument“ type

↑	⊖	→	←	1
⊕				
↓				
	InP	CLr	NPS	dC
	CHR	CFG	LYP	PΩ
	OUT	rEL	NOd	ΩHΩ
	SEr	EHL	EOr	Pt
		LEY	t.C.J	n i
			rAd	tC
			LER	dU
↑				
⊖				

DEF

LYP Selection of „instrument“ type

- selection of particular type of "instrument" is bound to relevant dynamic items

dC	DC voltmeter
PΩ	Process monitor
ΩHΩ	Ohmmeter
Pt	Thermometer for Pt xxx
n i	Thermometer for Ni xxxx
tC	Thermometer pro thermocouples
dU	Display for linear potentiometers

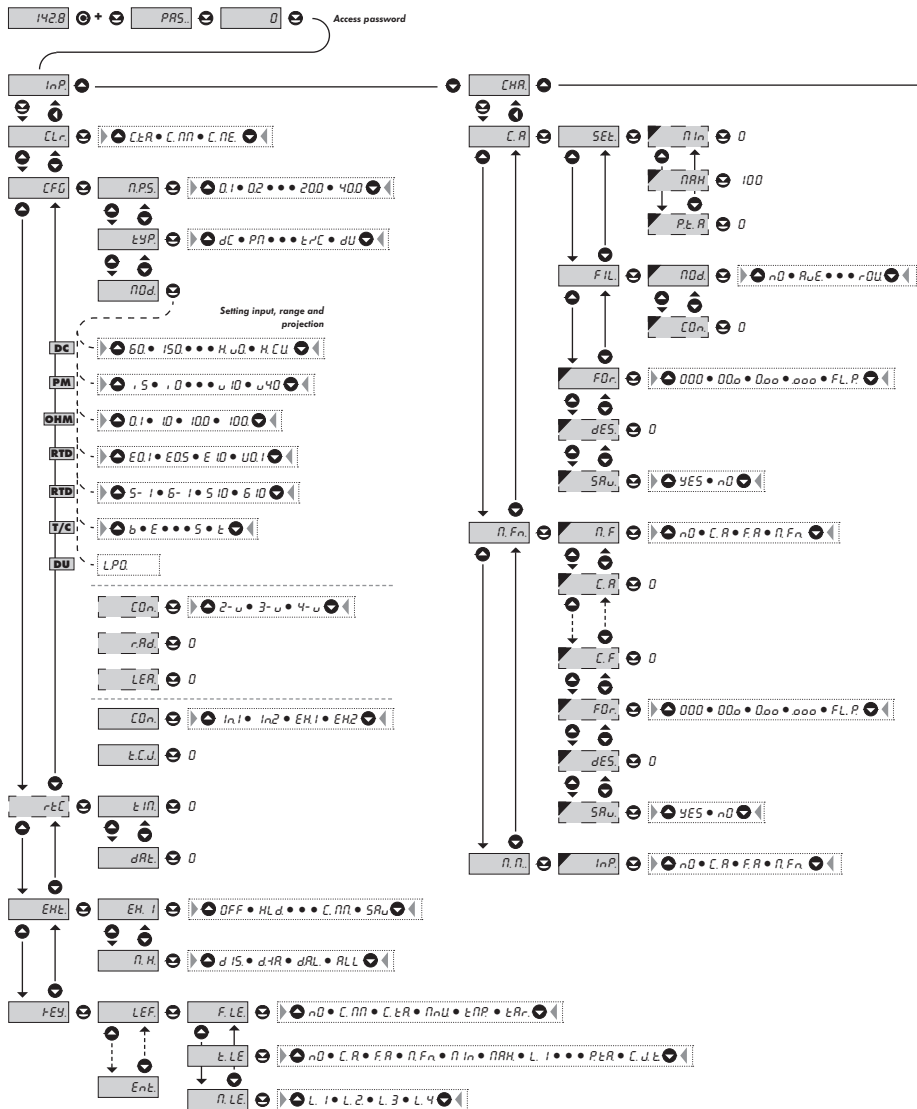

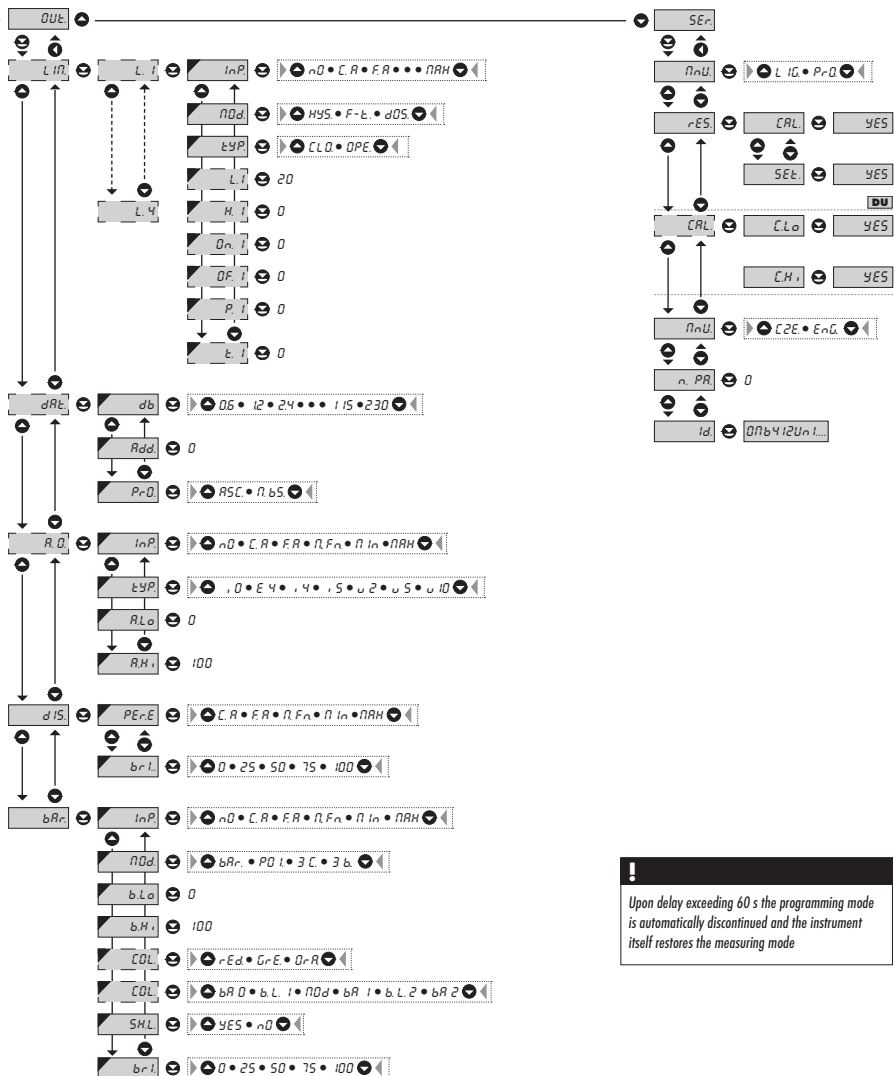

!
Upon delay exceeding 60 s the programming mode is automatically discontinued and the instrument itself restores the measuring mode

6.1.2c Selection of measuring range

↑
 Ⓞ →
 Ⓢ
 ↓

			DC	OHM	DEF
inp	CLr	NPS	60	0.1	DEF
CHR	CFG	LYP	150	1.0	
OUT	rEt	NOd	300	10.0	
SER	EHL	EOr	1.20	100	
	FEY	t.C.J	H1.U		
		rAd	H1.C		
		LER			
			PM		
			.5		
			.0		
			.4	DEF	
			u 2		
			u 5		
			u 10		
			u 40		
			RTD-Pt	T/C	
DEF			EO.1	b	
			EO.5	E	
			E1.0	J	
			U0.1	F	DEF
				n	
			RTD-Ni		
DEF			5-1	r	
			6-1	S	
			510	t	
			610		
			DU		DEF
			LPQ		

↑
Ⓢ

NOd Selection of instrument measuring range

Menu	Measuring range
60.	±60 mV
150.	±150 mV
300.	±300 mV
1.20	±1.2 V
HL.V.	±120 V/±250 V/±500 V*
HL.C.	0...1 A/0...5 A*

*only for option "A"

Menu	Measuring range
i 5	0...5 mA
i 0	0...20 mA
i 4	4...20 mA
u 2	±2 V
u 5	±5 V
u 10	±10 V
u 40	±40 V

Menu	Measuring range
0.1	0...100 Ω
1.0	0...1 kΩ
10.0	0...10 kΩ
100.	0...100 kΩ

Menu	Measuring range
EO.1	Pt 100 (3 850 ppm/°C)
EO.5	Pt 500 (3 850 ppm/°C)
E1.0	Pt 1000 (3 850 ppm/°C)
U0.1	Pt 100 (3 920 ppm/°C)

Menu	Measuring range
5-1	Ni 1 000 (5 000 ppm/°C)
6-1	Ni 1 000 (6 180 ppm/°C)
510	Ni 10 000 (5 000 ppm/°C)
610	Ni 10 000 (6 180 ppm/°C)

Menu	Type of thermocouple
B	T/C B
E	T/C E
J	T/C J
K	T/C K
N	T/C N
R	T/C R
S	T/C S
T	T/C T

6.1.2.d Selection of type of sensor connection

RTD **OHM** **T/C**

Navigation icons: ↑, ↓, ←, →, [C], [M]

inP	CLr	nPS	2-w	DEF
CHR	CFG	tYP	3-w	
DUt	r-tC	nDd	4-w	
SEr	EHL	EOm		
	tEY	rAd		
		LEr		

Navigation icons: ↑, ↓, ←, →, [C], [M]

inP	CLr	nPS	In.1	
CHR	CFG	tYP	In.2	DEF
DUt	r-tC	nDd	EH.1	
SEr	EHL	EOm	EH.2	
	tEY	t.C.J.		

EOm Selection of type of sensor connection

RTD **OHM**

2-w 2-wire connection

3-w 3-wire connection

4-w 4-wire connection

T/C

In.1 Measurement without reference thermocouple

- measuring cold junction at instrument brackets

In.2 Measurement with reference thermocouple

- measuring cold junction at instrument brackets with anti-series connected reference thermocouple

EH.1 Measurement without reference thermocouple

- the entire measuring set is working under invaried and constant temperature

EH.2 Measurement with reference thermocouple

- when using compensation box



Method and procedure of setting the cold junctions is described in separate chapter on page 80



For thermocouple type "B" the items CON. and t.C.J. are not available

6.1.2e Setting temperature of cold junction

T/C

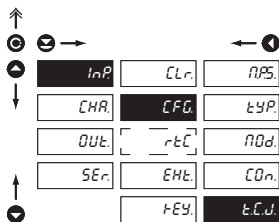

t.C.J. Setting temperature of cold junction

- range 0...99 °C with compensation box
- **DEF** = 23 °C

6.1.2f Compensation of 2-wire conduct

RTD OHM

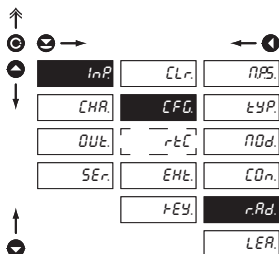

r.Ad. Offset of the beginning of the measuring range

- in cases when it is necessary to offset the beginning of the range by certain value, e.g. while using sensor in measuring head
- entered directly in Ohm (0...999)
- **DEF** = 0

6.1.2g Compensation of 2-wire conduct

RTD OHM

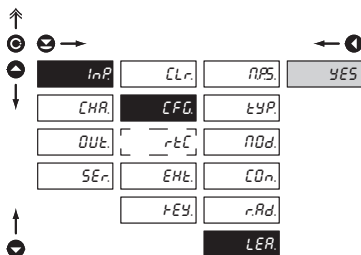

LEA Compensation of 2-wire conduct

- for measurement accuracy it is necessary to perform compensation of conduct always in case of 2-wire connection
- prior confirmation of the displayed prompt „YES“ it is necessary to substitute the sensor at the end of the conduct by a short-circuit
- **DEF** = 0

6.1.3 Setting the real time clock

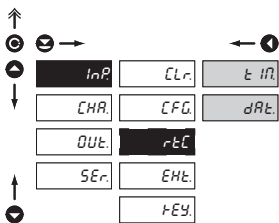

r-tC Setting the real time clock (RTC)

t IN Time setting

- format 23.59.59

dARt Date setting

- format DD.MM.YY

6.1.4a External input function selection

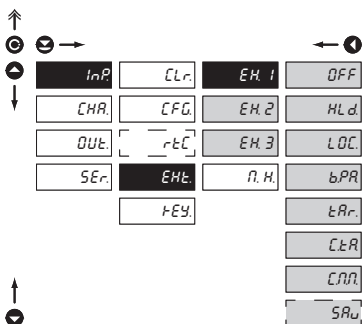

EHt External input function selection

OFF Input is off

HLD Activation of HOLD

LOC Locking keys on the instrument

bPR Activation of locking access into programming menu LIGHT/PROFI

tAR Tare activation

CLr Tare resetting

C.N.N Resetting min/max value

SARu Activation of measured data record in instrument memory (not in standard equipment)

- DEF EX. 1 > HLD.

- DEF EX. 2 > LOC.

- DEF EX. 3 > TAR.

*

Setting procedure is identical for EX. 2 and EX. 3

6.1.4b Selection of function "HOLD"

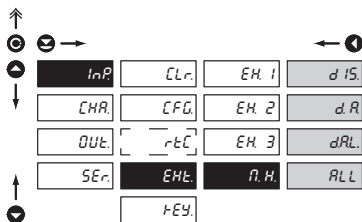
H.H. Selection of function "HOLD"

- | | |
|------|--|
| d IS | "HOLD" locks only the value displayed |
| d R | "HOLD" locks the value displayed and on AO |
| d RL | "HOLD" locks the value displayed, on AO and limit evaluation |
| RL | "HOLD" locks the entire instrument |

6.1.5a Optional accessory functions of the keys

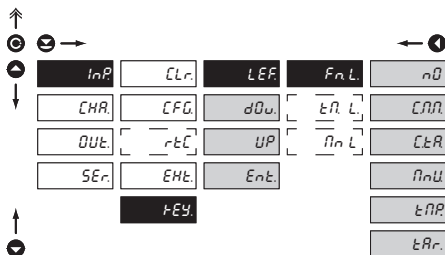
Fn.L. Assigning further functions to instrument keys

keys

- „Fn. L.“ > executive functions
- „TM. L.“ > temporary projection of selected values
- „MN. L.“ > direct access into menu on selected item

- | | |
|-----|--|
| nD | Key has no further function |
| CLN | Resetting min/max value |
| CLR | Tare resetting |
| MNU | Direct access into menu on selected item |
| ENP | Temporary projection of selected values |
| ERR | Tare function activation |
- after confirmation of this selection the "MENU" item is displayed on superior menu level, where required selection is performed
 - after confirmation of this selection the item "TEMPOR." is displayed on superior menu level, where required selection is performed

Preset values of the control keys **DEF**:

LEFT	Show Tare
UP	Show Max. value
DOWN	Show Min. value
ENTER	w/o function



Setting is identical for LEFT, DOWN, UP and ENTER

6.1.5b Optional accessory functions of the keys - Temporary projection

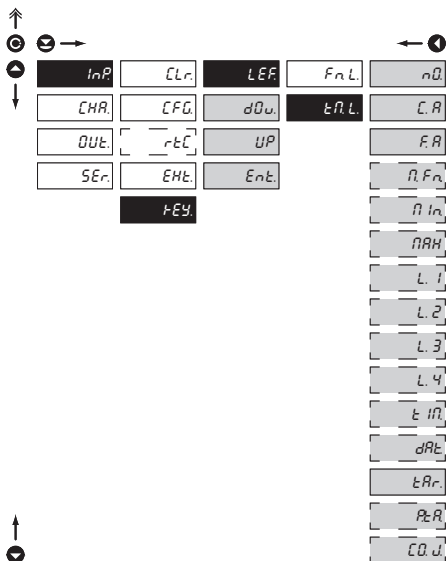

tN.L. Temporary projection of selected item

- "Temporary" projection of selected value is displayed for the time of keystroke
- "Temporary" projection may be switched to permanent by pressing **C** + "Selected key", this holds until the stroke of any key

- nD** Temporary projection is off
- C.R** Temporary projection of "Channel A" value
- F.R** Temporary projection of "Channel A" value after processing digital filters
- n.Fn** Temporary projection of "Mathematic functions" value
- nIn** Temporary projection of "Min. value"
- nRH** Temporary projection of "Max. value"
- L.1** Temporary projection of "Limit 1" value
- L.2** Temporary projection of "Limit 2" value
- L.3** Temporary projection of "Limit 3" value
- L.4** Temporary projection of "Limit 4" value
- tIn** Temporary projection of "TIME" value
- dRE** Temporary projection of "DATE" value
- tRr** Temporary projection of "TARE" value
- P.tR** Temporary projection of "P. TARE" value
- CQ.J** Temporary projection of "CJC" value

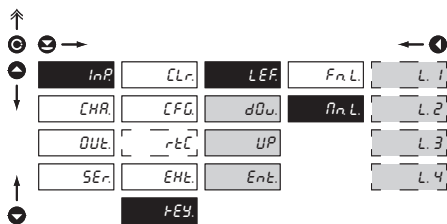

Setting is identical for LEFT, DOWN, UP and ENTER

6.1.5c Optional accessory functions of the keys - Direct access to item

n.L. Assigning access to selected menu item

- L.1 Direct access to item "LIM 1"
- L.2 Direct access to item "LIM 2"
- L.3 Direct access to item "LIM 3"
- L.4 Direct access to item "LIM 4"

!
Setting is identical for LEFT, DOWN, UP and ENTER

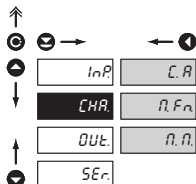
6.2 Setting "PROFI" - CHANNELS



The primary instrument parameters are set in this menu

- C.R** Setting parameters of measuring "Channel"
- n.Fn** Setting parameters of mathematic functions
- n.n** Selection of access and evaluation of Min/max value

6.2.1 a Display projection

DC PM DU OHM

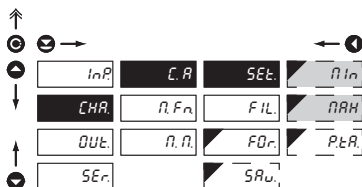

SEt Setting display projection

n.In Setting display projection for minimum value of

- input signal
- range of the setting is -99...999
- **DEF** = 0

n.n Setting display projection for maximum value of

- input signal
- range of the setting is -99...999
- **DEF** = 100

6.2.1 b Setting fixed tare

DC PM DU OHM

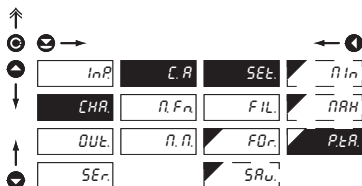

P.tA Setting "Fixed tare" value

- setting is designed for the event when it is necessary to firmly shift the beginning of the range by known size
- when setting (P. TA. > 0) display shows "T" symbol
- range of the setting is 0...999
- **DEF** = 0

6.2.1 c Digital filters

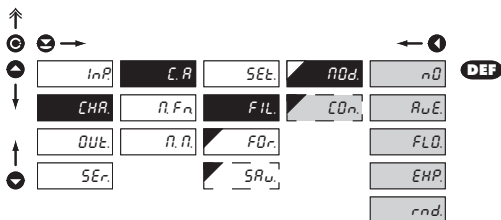

nD Selection of digital filters

- at times it is useful for better user projection of data on display to modify it mathematically and properly, where the following filters may be used:

nD Filters are off

R.U.E Measured data average

- arithmetic average from given number („CON.“) of measured values
- range 2...100

F.L.D. Selection of floating filter

- floating arithmetic average from given number („CON.“) of measured data and updates with each measured value
- range 2...30

E.H.P. Selection of exponential filter

- integration filter of first prvnho grade with time constant („CON.“) measurement
- range 2...100

r.n.d. Measured value rounding

- is entered by any number, which determines the projection step (e.g: „CON.“=2,5 > display 0, 2.5, 5,...)

C.D.n. Setting constants

- this menu item is always displayed after selection of particular type of filter

DEF = 2

6.2.1d Projection format - positioning of decimal point

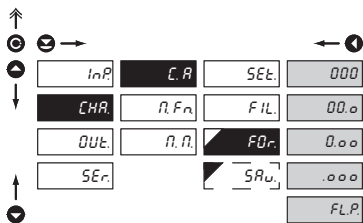
FDr Selection of decimal point

- the instrument allows for classic projection of a number with positioning of the DP as well as projection with floating DP, allowing to display a number in its most exact form „FL.P.“

 Setting DP - XXX.

DEF
 Setting DP - XX.x

 Setting DP - X.xx

 Setting DP - .xxx

 Floating DP

6.2.1e Selection of storing data into instrument memory

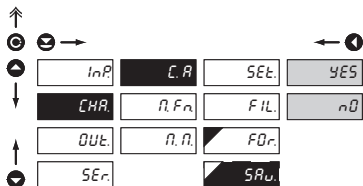
SAu Selection of storing data into instrument memory

- by selection in this item you allow to register values into instrument memory
- another setting in item "OUT. > MEM." (not in standard experiment)

 Measured data are stored in the memory

 Measured data are not stored

6.2.2a Mathematic functions

Navigation icons:

$\ln P$	$C.R$	$n.F$	OFF
CHR	$n.Fn$	$C.R$	PQL
OUT	$n.n$	$C.b$	IRn
SEr		$C.C$	LOG
		$C.d$	EHP
		$C.E$	POu
		$C.F$	rt
		FDr	SIn
		SRu	

 $n.F$ Selection of mathematic functions

OFF Mathematic functions are off

PQL Polynomial

$$Ax^2 + Bx^4 + Cx^3 + Dx^2 + Ex + F$$

IRn $1/x$

$$\frac{A}{x^2} + \frac{B}{x^4} + \frac{C}{x^3} + \frac{D}{x^2} + \frac{E}{x} + F$$

LOG Logarithm

$$A \times \ln\left(\frac{Bx+C}{Dx+E}\right) + F$$

EHP Exponential

$$A \times e^{\left(\frac{Bx+C}{Dx+E}\right)} + F$$

POu Power

$$A \times (Bx+C)^{(Dx+E)} + F$$

rt Root

$$A \times \sqrt{\frac{Bx+C}{Dx+E}} + F$$

SIn Sin x

$$A \sin^5 x + B \sin^4 x + C \sin^3 x + D \sin^2 x + E \sin x + F$$

$C.-$ Setting constants for calculation of mat. functions

- this menu is displayed only after selection of given mathematic function

6.2.2b **Mathematic functions - decimal point**

InP	C.R	<input checked="" type="checkbox"/> N.F	000
CHR	N.Fn	<input checked="" type="checkbox"/> C.R	00.0
Out	N.N	<input checked="" type="checkbox"/> C.b	0.00
SEr		<input checked="" type="checkbox"/> C.C	.000
		<input checked="" type="checkbox"/> C.d	FL.P
		<input checked="" type="checkbox"/> C.E	
		<input checked="" type="checkbox"/> C.F	
		<input checked="" type="checkbox"/> FDr	
		<input checked="" type="checkbox"/> SAU	

DEF

FDr **Selection of decimal point**

- the instrument allows for classic projection of a number with positioning of the DP as well as projection with floating DP, allowing to display a number in its most exact form „FL.P.“

 Setting DP - XXXXXX.

 Setting DP - XXXX.x

 Setting DP - XXXX.xx

 Setting DP - XXX.xxx

 Floating DP

DEF

6.2.2c **Mathematic functions - selection of storing data into instrument memory**

InP	C.R	<input checked="" type="checkbox"/> N.F	YES
CHR	N.Fn	<input checked="" type="checkbox"/> C.R	n0
Out	N.N	<input checked="" type="checkbox"/> C.b	
SEr		<input checked="" type="checkbox"/> C.C	
		<input checked="" type="checkbox"/> C.d	
		<input checked="" type="checkbox"/> C.E	
		<input checked="" type="checkbox"/> C.F	
		<input checked="" type="checkbox"/> FDr	
		<input checked="" type="checkbox"/> SAU	

SAU **Selection of storing data into instrument memory**

- by selection in this item you allow to register values into instrument memory
 - another setting in item "OUT. > MEM." (not in standard experiment)

 Measured data are stored in the memory

 Measured data are not stored

6.2.3 Selection of evaluation of min/max value

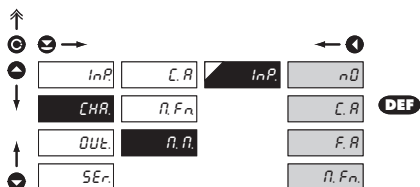

InP. Selection of evaluation of min/max value

- selection of value from which the min/max value will be calculated

n0 Evaluation of min/max value is off

C.A From "Channel A"

F.B From "Channel A" after digital filters processing

M.F.n. From "Mathematic functions"

6.3 Setting „PROFI“ - OUTPUTS

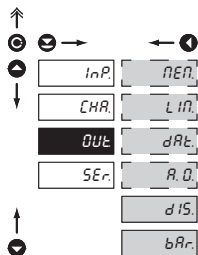

In this menu it is possible to set parameters of the instrument output signals

- nEn. Setting data logging into memory
- L in. Setting type and parameters of limits
- dAR. Setting type and parameters of data output
- R. D. Setting type and parameters of analog output
- d IS. Setting display projection and brightness
- bAR. Setting bargraph projection and brightness

6.3.1a Selection of mode of data logging into instrument memory

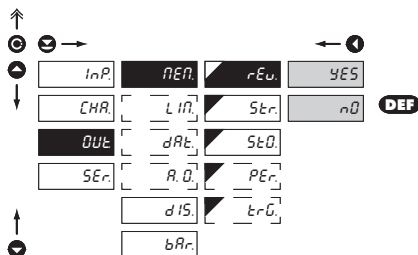

rEu. Selection of the mode of data logging

- selection of the mode in the event of full instrument memory

- nD. Rewriting values prohibited
- YES. Rewriting values permitted, the oldest get rewritten by the latest

6.3.1b Setting data logging into instrument memory - RTC

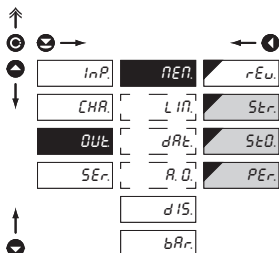

StEr Start of data logging into instrument memory

- time format HH.MM.SS

StOd Stop data logging into instrument memory

- time format HH.MM.SS

PEr Period of data logging into instrument memory

- determines the period in which values will be logged in an interval delimited by the time set under items START and STOP

- time data hold valid for one day, where the logging is valid for every day without limitation

- time format HH.MM.SS

- item not displayed if "STORE" is selected in menu (INP. > EXT.)

6.3.1c Setting data logging into instrument memory - FAST

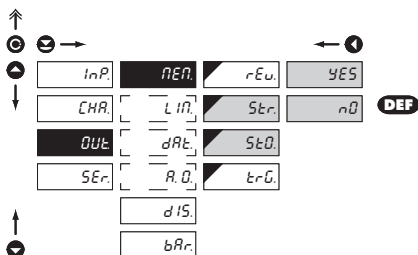

StEr Start of data logging into instrument memory

StOd Stop data logging into instrument memory

- time format HH.MM.SS

tErG Setting logging data into inst. memory

- values will be logged in an interval delimited by the time set under items START and STOP, time data hold valid for one day, where the logging is valid for every day without limitation

- logging data into inst. memory is governed by the following selection, which determines how many percent of the memory is reserved for data logging prior to initiation of trigger impulses

- initiation is on ext. input or control key

10% Reser. of 10 % memory prior init. of data logging

50% Reser. of 50 % memory prior init. of data logging

90% Reser. of 90 % memory prior init. of data logging

rDl. After initiation of data logging the memory is cyclically transcribed

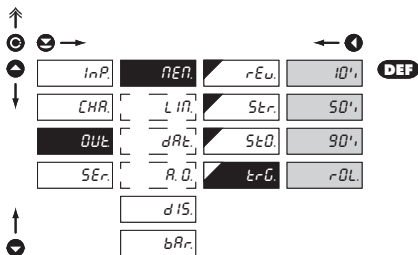

6.3.2a Selection of input for limits evaluation

!
Setting is identical for LIM 2, LIM 3 and LIM 4

InP Selection evaluation of limits

- selection of value from which the limit will be evaluated

- nD** Limit evaluation is off
- CR** Limit evaluation from "Channel A"
- FR** Limit evaluation from "Channel A" after digital filters processing
- nFn** Limit evaluation from "Mathematic functions"
- nIn** Limit evaluation from "Min.value"
- nRH** Limit evaluation from "Max.value"

6.3.2b Selection of type of limit

!
Setting is identical for LIM 2, LIM 3 and LIM 4

nDd Selection the type of limit

- HYS** Limit is in mode "Limit, hysteresis, delay"
 - for this mode the parameters of "LIM. L." are set, at which the limit will shall react, "HYS. L." the hysteresis range around the limit (LIM $\pm 1/2$ HYS) and time "TIM. L." determining the delay of relay switch-on
- F-t** Frame limit
 - for this mode the parameters are set for interval "ON. L." the relay switch-on and "OFF. L." the relay switch-off
- dOS** Dosing limit (periodic)
 - for this mode the parameters are set for "PER. L." determining the limit value as well as its multiples at which the output is active and "TIM. L." indicating the time during which is the output active

6.3.2c Selection of type of output

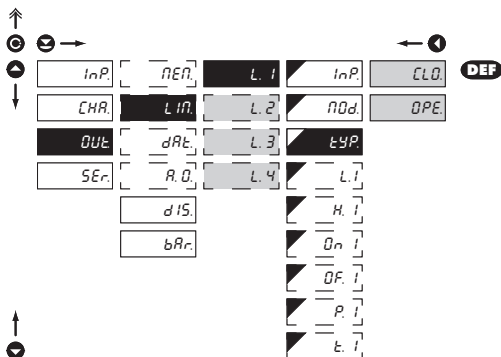

tYP Selection of type of output

CLD Output switches on when condition is met

OPE Output switches off when condition is met

Setting is identical for LIM 2, LIM 3 and LIM 4

6.3.2d Setting values for limits evaluation

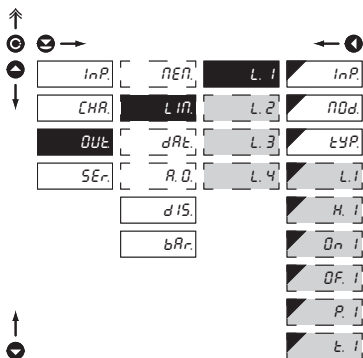

L.1 Setting limit for switch-on

- for type "HYSTER"

H.1 Setting hysteresis

- for type "HYSTER"
- indicates the range around the limit (in both directions, LIM. $\pm 1/2$ HYS.)

On.1 Setting the outset of the interval of limit switch-on

- for type "FROM.."

DF.1 Setting the end of the interval of limit switch-on

- for type "FROM.."

P.1 Setting the period of limit switch-on

- for type "DOSING"

t.1 Setting the time switch-on of the limit

- for type "HYSTER" and "DOSING"

Setting is identical for LIM 2, LIM 3 and LIM 4

6.3.3a Selection of data output baud rate

inP	REN	bd	0.6
CHR	LIN	Add	1.2
OUT	dRL	PrD	2.4
SEr	R.D		4.8
	d15		9.6
	bRr		19.2
			38.4
			57.6
			115
			230

bd Selection of data output baud rate

0.6	Rate - 600 Baud
1.2	Rate - 1 200 Baud
2.4	Rate - 2 400 Baud
4.8	Rate - 4 800 Baud
9.6	Rate - 9 600 Baud
19.2	Rate - 19 200 Baud
38.4	Rate - 38 400 Baud
57.6	Rate - 57 600 Baud
115	Rate - 115 200 Baud
230	Rate - 230 400 Baud

6.3.3b Setting instrument address

inP	REN	bd
CHR	LIN	Add
OUT	dRL	PrD
SEr	R.D	
	d15	
	bRr	

Add Setting instrument address

- setting in range 0...31
- **DEF** = 00

6.3.3c Selection of data output protocol

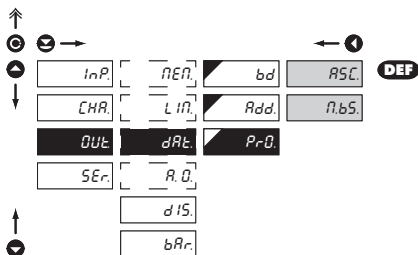

PrO. Selection of the type of analog output

- ASCL Data protocol ASCII
- n.bS Data protocol DIN MessBus

6.3.4a Selection of input for analog output

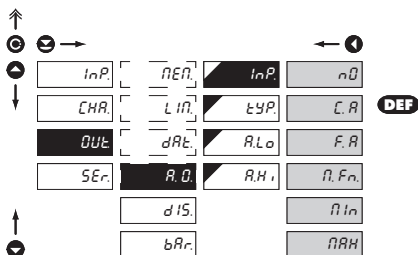

InP. Selection evaluation analog output

- selection of value from which the analog output will be evaluated

- nO AO evaluation is off
- CR AO evaluation from "Channel A"
- F.R AO evaluation from "Channel A" after digital filters processing
- n.Fn AO evaluation from "Math.functions"
- nIn AO evaluation from "Min.value"
- NRH AO evaluation from "Max.value"

6.3.4b Selection of the type of analog output

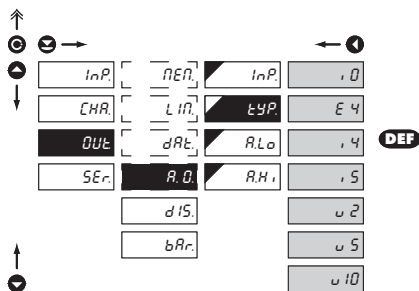

ÉYP Selection of the type of analog output

Type - 0...20 mA

Type - 4...20 mA

- with indication of error statement (< 3,0 mA)

Type - 4...20 mA

Type - 0...5 mA

Type - 0...2 V

Type - 0...5 V

Type - 0...10 V

6.3.4c Setting the analog output range

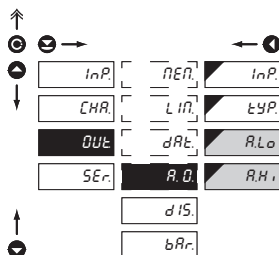

RLo Setting the analog output range

- analog output is isolated and its value corresponds with displayed data. It is fully programmable, i.e. it allows to assign the AO limit points to two arbitrary points of the entire measuring range

Assigning the display value to the beginning of the AO range

- range of the setting is -99...999

- **DEF** = 0

Assigning the display value to the end of the AO range

- range of the setting is -99...999

- **DEF** = 100

6.3.5a Selection of input for display projection

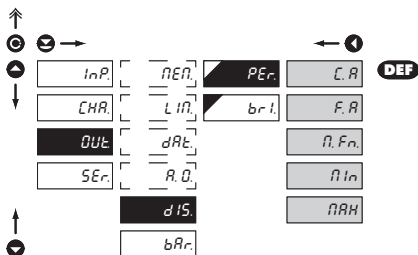

PEr Selection display projection

- selection of value which will be shown on the instrument display

- Projection of values from "Channel A"
- Projection of values from "Channel A" after digital filters processing
- Projection of values from "Math.functions"
- Projection of values from "Min.value"
- Projection of values from "Max.value"

6.3.5b Selection of display brightness

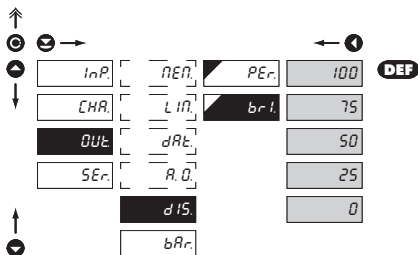

br i Selection of display brightness

- by selecting display brightness we may appropriately react to light conditions in place of instrument location

- Display is off
- after keystroke display turns on for 10 s
- Display brightness - 25%
- Display brightness - 50%
- Display brightness - 75%
- Display brightness - 100%

6.3.6a Bargraph - Selection of projection input

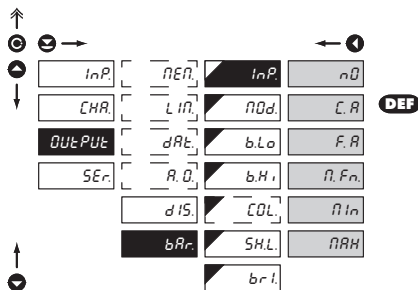
**InP** Selection of bargraph evaluation

- selection of value from which the analog output will be evaluated

- нП** Analog evaluation is off
- СР** From "Channel A"
- ФР** From "Channel A" after digital filter modification
- ПФ** From "Mathematic function"
- ПН** From "Minimum value"
- ПРН** From "Maximum value"

6.3.6b Bargraph - Selection of projection mode

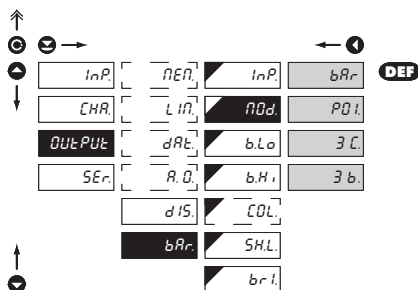
**бRr** Selection of bargraph projection mode

- бRr** Column projection
- the display shows only a column in one color
- ПДЛ** Point projection
- the display shows one point in one color
- ЗС** 3-colored column projection
- change of color is determined by set limits (COL. > BAND)
- upon exceeding the limit the color of the entire display, i.e. there is always only one column of one color lit
- Зб** 3-colored bar projection, cascade
- change of color is determined by the said limits (COL. > BAND)
- upon exceeding a limit color of the given display section is changing, i.e. the display may shine up to three colors at a time

6.3.6c Bargraph - Setting the projection range

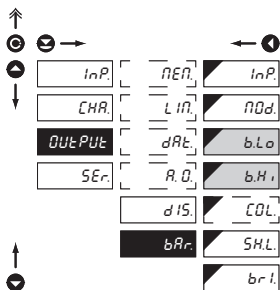

bAr. Setting the bargraph projection range

- setting is the same as the setting for main display projection

bLo Setting bargraph projection for minimum input signal value

- range of the setting is -99...999

- **DEF** = 0

bHi Setting bargraph projection for maximum input signal value

- range of the setting is -99...999

- **DEF** = 100

6.3.6d Bargraph - Setting color

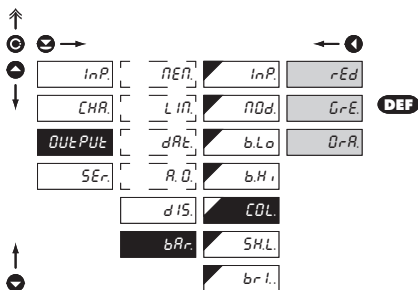

COL Selection of bargraph color

- the item "COLOR" is displayed only with selected mode ("BAR. > MOD.") "BAR." or "POI."

rEd Red color

GrE Green color

OrR Orange color

6.3.6e Bargraph - Color setting

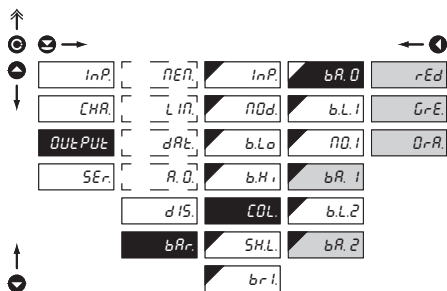
bR.0 Selection of bargraph color

- the item "COL" is displayed only with selected mode ("BAR. > MOD.") "3 C." or "3 B."

ErEd Red color

GrE Green color

OrR Orange color

- **DEF** = Green (Band 0)

- **DEF** = Orange (Band 1)

- **DEF** = Red (Band 2)



Setting is identical for BA. 1 and BA. 2

6.3.6f Bargraph - Setting the color changes bands

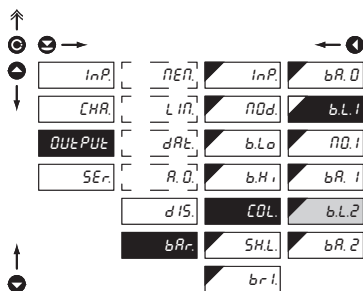
b.L.1 Setting color limits for color projection

- the item "COL" is displayed only with selected mode ("BAR. > MOD.") "3 C." or "3 B."

- items „b.L.1” and „b.L.2” determine the borders of the bargraph color changes

b.L.1 Boundary between bands 0 - 1

b.L.2 Boundary between bands 1 - 2

- **DEF** = 33 (b.L.1)

- **DEF** = 66 (b.L.2)



Setting is identical for B. L. 2

6.3.6g Bargraph - Selection of inverse projection

InP	NEP	InP	bA.0	nD.r	DEF
CHR	L IN	nD.d	b.L.l	In.u	
OUTPUT	dARt	b.L.o	nD.l		
SER	R.D.	b.H.l	b.A.l		
	d15	COL	b.L.2		
	bA.r	SH.L	b.A.2		
		br.l			

nD.l Selection of inverse projection of "Band 0"

- the item "COLORS" is displayed only with selected mode ("BAR. > MOD. 1") "3 C." or "3 B."
- setting „b. A. 1" is designed for projection where indication of zero center is required

nD.r. Column in "BA. 0" moves from left to right

In.u. Column in "BA. 0" moves from right to left

6.3.6h Bargraph - Selection of limits projection

InP	NEP	InP	YES	DEF
CHR	L IN	nD.d	nD	
OUTPUT	dARt	b.L.o		
SER	R.D.	b.H.l		
	d15	COL		
	bA.r	COL		
		SH.L		
		br.l		

SH.L. Selection of limit projection on the bargraph

- limits are always displayed orange, always by one degree lighter or darker

YES Limits are projected

nD Limity are not projected

6.3.6i Bargraph - Selection of display brightness

InP	NEP	InP	100%	DEF
CHR	L IN	nD.d	75%	
OUTPUT	dARt	b.L.o	50%	
SER	R.D.	b.H.l	25%	
	d15	COL	0%	
	bA.r	SH.L		
		br.l		

br.l. Selection of bargraph brightness

- after pres. the key the display lights up for 0 s

0 Bargraph is off

25 Brightness - 25%

50 Brightness - 50%

75 Brightness - 75%

100 Brightness - 100%

6.4 Setting "PROFI" - SERVIS

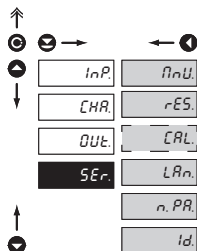

The instrument service functions are set in this menu

PRO	Selection of menu type LIGHT/PROFI
RES	Restore instrument manufacture setting and calibration
RL	Input range calibration for „DU“ version
LRn	Language version of instrument menu
n.PW	Setting new access password
Id	Instrument identification

6.4.1 Selection of type of programming menu

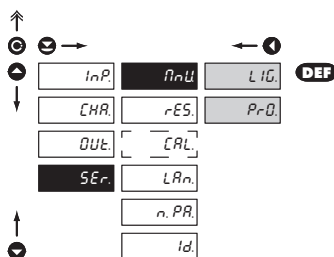

Change of setting is valid upon next access into menu

PRO Selection of menu type - LIGHT/PROFI

- enables setting the menu complexity according to user needs and skills

LIG Active LIGHT menu

- simple programming menu, contains only items necessary for configuration and instrument setting
- linear menu > items one after another

P-0 Active PROFI menu

- complete programming menu for expert users
- tree menu

6.4.2 Restoration of manufacture setting

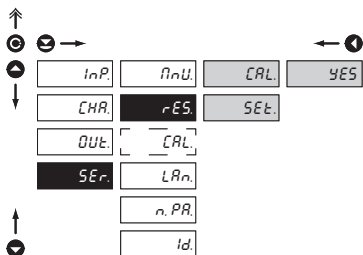

rES. Restoring manufacture setting of the instrument

- in the event of erroneous setting or calibration it is feasible to restore manufacture setting. Prior execution of any changes you will be asked to confirm your preference „YES“

CAL. Restore manufacture instrument calibration

SET. Restore manufacture instrument setting

- loading manufacture setting (items denoted DEF)
- prior execution of changes you will be asked to confirm your preference “YES”

Jobs performed	Restore	
	Calibration	Setting
cancels USER menu rights	✓	✓
deletes table of items order in USER - LIGHT menu	✓	✓
adds items from manufacture to LIGHT menu	✓	✓
deletes data stored in FLASH	✓	✓
cancels or linearization tables	✓	✓
clears tare	✓	✓
clears conduct resistances	✓	✓
restore manufacture calibration	✓	✗
restore manufacture setting	✗	✓

6.4.3 Calibration - Input range

DU

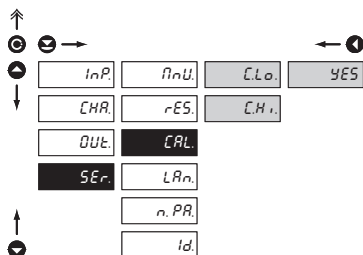
CAL Input range calibration

- when "C. Lo" is displayed, move the potentiometer traveller to the required minimum position and confirm by „Enter“, calibration is confirmed by "YES"
- when "C. Hi" is displayed, move the potentiometer traveller to required maximum position and confirm by „Enter“, calibration is confirmed by „YES"

6.4.4 Selection of instrument menu language version

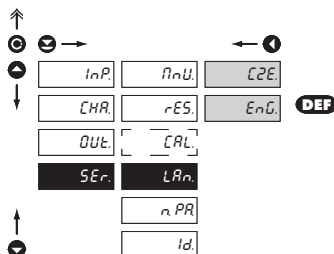
LAn. Selection of instrument menu language version

- | | |
|------|-------------------------------|
| CZE. | Instrument menu is in Czech |
| EN. | Instrument menu is in English |

6.4.5 Setting new access password

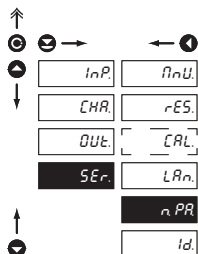
n.PR. Setting new password for access to LIGHT and PROFi menu

- this selection enables changing number code that blocks the access into LIGHT and PROFi Menu.
- range of the number code is 0...999
- universal password in the event of loss is „177"

6.4.6 Instrument identification

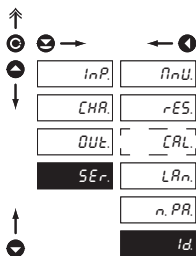

Id. Projection of instrument SW version

- display shows type identification of the instrument, SW number, SW version and current input setting (Mode)
- if the SW version reads a letter on first position, it is a customer SW

7.0 Setting items into "USER" menu

- **USER** menu is designed for users who need to change only several items of the setting without the option to change the primary instrument setting (e.g. repeated change of limit setting)
- there are no items from manufacture permitted in **USER** menu
- on items indicated by inverse triangle  item
- setting may be performed in **LIGHT** or **PROFI** menu, with the **USER** menu then overtaking the given menu structure



- For user operation
- Menu items are set by the user (Profi/Light) as per request
- Access is not password protected

Setting

flashing legend - current setting is displayed



n0

item will not be displayed in USER menu

YES

item will be displayed in USER menu with editing option

SHD

item will be solely displayed in USER menu

Setting sequence of items in "USER" menu

In compiling USER menu from active LIGHT menu the items (max. 10) may be assigned a sequence, in which they will be projected in the menu



Example:

Into USER menu were selected these items

(keys +) > C. TA., L. 1, L. 2, L. 3, for which we have preset this sequence (keys +):

C. TA.	5
L. 1	0 (sequence not determined)
L. 2	2
L. 3	1

Upon entering USER menu

(key) items will be projected in the following sequence: L. 3 > L. 2 > C.TA. > L. 1

Instrument with input for temperature measurement with thermocouple allows to set two types of measurement of cold junction.

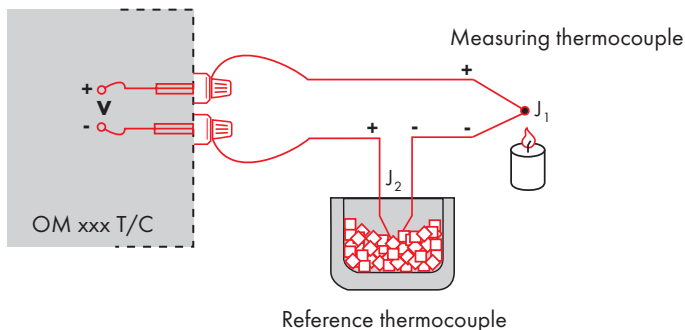

WITH REFERENCE THERMOCOUPLE

- a reference thermocouple may be located in the same place as the measuring instrument or in place with stable temperature/compensation box
- when measuring with reference thermocouple set $\mathcal{L}D_n$ in the instrument menu to $in2$ or $EH2$
- when using a thermostat (a compensation box or environment with constant temperature) set in the instrument menu $\mathcal{L}C_n$ its temperature (applies for setting $\mathcal{L}D_n$ to $EH2$)
- if the reference thermocouple is located in the same environment as the measuring instrument then set in the instrument menu $\mathcal{L}D_n$ to $in2$. Based on this selection the measurement of the ambient temperature is performed by a sensor located in the instrument terminal board.

WITHOUT REFERENCE THERMOCOUPLE

- inaccuracy originating from the creation of dissimilar thermocouples on the transition point terminal/conductor of the thermocouple is not compensated for in the instrument
- when measuring without reference thermocouple set $\mathcal{L}D_n$ in the instrument menu to $in1$ or $EH1$
- when measuring temperature without reference thermocouple the error in measured data may be as much as 10°C (applies for setting $\mathcal{L}D_n$ to $EH1$)

The instruments communicate via serial line RS232 or RS485. For communication they use the ASCII protocol. Communication runs in the following format:

ASCII: 8 bit, no parity, one stop bit
 DIN MessBus: 7 bit, even parity, one stop bit

The transfer rate is adjustable in the instrument menu. The instrument address is set in the instrument menu in the range of 0 + 31. The manufacture setting always presets the ASCII protocol, rate of 9600 Baud, address 00. The type of line used - RS232 / RS485 - is determined by an output board automatically identified by the instrument.

The commands are described in specification you can find at www.orbit.merret.cz/rs.

DETAILED DESCRIPTION OF COMMUNICATION VIA SERIAL LINE

Activity	Data transferred										
Data solicitation (PC)	#	A	A	<CR>							
Data transmission (Instrument)	>	R	<SP>	D	D	D	D	D	(D)	(D)	<CR>
Command confirm. (Instr.) - OK	!	A	A	<CR>							
Command confirm. (Instr.) - Bad	?	A	A	<CR>							
Instrument identification	#	A	A	1Y	<CR>						
HW identification	#	A	A	1Z	<CR>						
One-time measurement	#	A	A	7X	<CR>						
Repeated measurement	#	A	A	8X	<CR>						

LEGEND

#	35	23 _H	Command beginning
A	A	0...31	Two signs of instrument address (sent in ASCII - tens and ones, e.g. "01", "99" universal
<CR>	13	0D _H	Carriage return
<SP>	32	20 _H	Space
D			Data - usually signs "0"... "9", ".", "-", ";", (D) - DP. and (-) may prolong data
R	50 _H ...57 _H		Relay and Tare status
!	33	21 _H	Positive command confirmation (ok)
?	63	3F _H	Negative command confirmation (bad)
>	62	3E _H	Beginning of the data transmitted

RELAY, TARE

Sign	Relay 1	Relay 2	Tare	Change relay 3/4
P	0	0	0	0
Q	1	0	0	0
R	0	1	0	0
S	1	1	0	0
T	0	0	1	0
U	1	0	1	0
V	0	1	1	0
W	1	1	1	0
p	0	0	0	1
q	1	0	0	1
r	0	1	0	1
s	1	1	0	1
t	0	0	1	1
u	1	0	1	1
v	0	1	1	1
w	1	1	1	1

ERROR	CAUSE	ELIMINATION
<i>E. d. U</i>	Number is too small (large negative) to be displayed	change DP setting, channel constant setting
<i>E. d. Q</i>	Number is too large to be displayed	change DP setting, channel constant setting
<i>E. E. U</i>	Number is outside the table range	increase table values, change input setting (channel constant setting)
<i>E. E. Q</i>	Number is outside the table range	increase table values, change input setting (channel constant setting)
<i>E. I. U</i>	Input quantity is smaller than permitted input quantity range	change input signal value or input (range) setting
<i>E. I. Q</i>	Input quantity is larger than permitted input quantity range	change input signal value or input (range) setting
<i>E. H. U</i>	A part of the instrument does not work properly	send the instrument for repair
<i>E. EE</i>	Data in EEPROM corrupted	perform restoration of manufacture setting, upon repeated error statement send instrument for repair
<i>E. dR</i>	Data in EEPROM outside the range	perform restoration of manufacture setting, upon repeated error statement send instrument for repair
<i>E. CL</i>	Memory was empty (presetting carried out)	upon repeated error statement send instrument for repair, possible failure in calibration

INPUT

range is adjustable

±60 mV	>100 MOhm
±150 mV	>100 MOhm
±300 mV	>100 MOhm
±1200 mV	>100 MOhm

DC

Input U
Input U
Input U
Input U

range is adjustable

0...1 A	> 30 mV
0...5 A	> 150 mV
±120 V	20 MOhm
±250 V	20 MOhm
±500 V	20 MOhm

DC - option "A"

Input I
Input I
Input U
Input U
Input U

range is adjustable

0/4...20 mA	< 400 mV
±2 V	1 MOhm
±5 V	1 MOhm
±10 V	1 MOhm
±40 V	1 MOhm

PM

Input I
Input U
Input U
Input U
Input U

range is adjustable

0...100 Ohm
0...1 kOhm
0...10 kOhm
0...100 kOhm

OHM

Connection:

2, 3 or 4 wire

RTD

Pt xxxx

-200°...850°C

Ni xxxx

-30,0°...199,9°C

Type Pt:

100/500/1 000 Ohm, s 3850 ppm/°C
100 Ohm, s 3920 ppm/°C

Type Ni:

Ni 1 000/ Ni 10 000 s 5000/6180 ppm/°C

Connection:

2, 3 or 4 wire

T/C

range is adjustable in configuration menu

Type:

J (Fe-CuNi)	-200°...900°C
K (NiCr-Ni)	-200°...1 300°C
T (Cu-CuNi)	-200°...400°C
E (NiCr-CuNi)	-200°...690°C
B (PtRh30-PtRh6)	300°...1 820°C
S (PtRh10-Pt)	-50°...1 760°C
R (Pt13Rh-Pt)	-50°...1 740°C
N (Omegalloy)	-200°...1 300°C

DU

Voltage of lin. pot.

2,5 VDC/6 mA

min. potentiometer resistance is 500 Ohm

PROJECTION

Display 1:

24-segment 3-color bargraph

Display2:

auxiliary 3-digit display, intensive red or green, 7-segment LED, letter height 9,1 mm

Projection:

24 LED/99...999

Decimal point:

adjustable - in menu

Brightness:

adjustable - in menu

INSTRUMENT ACCURACY

TC:

100 ppm/°C

Accuracy:

±0,1 % of range + 1 digit

±0,15 % of range + 1 digit

±0,3 % of range + 1 digit

RTD, T/C**PWR****Above accuracies apply for projection 9999**

Resolution:

0,01°/0,1°/1°

RTD

Rate:

0,1...40 measurements/s

Overload capacity:

10x (t < 100 ms) not for 400 V and 5 A,

2x (long-term)

Linearisation:

by linear interpolation in 50 points

- solely via OM Link

Digital filters:

Averaging, Floating average, Exponential filter, Rounding

Comp. of conduct:

max. 40 Ohm/100 Ohm

RTD

Comp. of cold junct.:

adjustable

T/C

0°...99°C or automatic

Functions:

Tare - display resetting

Hold - stop measuring (at contact)

Lock - control key locking

MM - min/max value

Mathematic functions

OM Link:

company communication interface for setting, operation and update of instrument SW

Watch-dog:

reset after 400 ms

Calibration:

at 25°C and 40 % of r.h.

COMPARATOR

Type:

digital, adjustable in menu

Mode:

Hysteresis, From, Dosing

Limits:

-99...999

Hysteresis:

0...999

Delay:

0...99,9 s

Outputs:

2x relays with switch-on contact (Form A)

(230 VAC/30 VDC, 3 A)*

2x relays with switch-off contact (Form C)

(230 VAC/50 VDC, 3 A)*

Relay:

1/8 HP 277 VAC, 1/10 HP 125 V, Pilot Duty D300

* values apply for resistance load

DATA OUTPUTS

Protocols:	ASCII, DIN MessBus
Data format:	8 bit + no parity + 1 stop bit (ASCII) 7 bit + even parity + 1 stop bit (MessBus)
Rate:	600...230 400 Baud
RS 232:	isolated, two-way communication
RS 485:	isolated, two-way communication, addressing (max. 31 instruments)
PROFIBUS	Data protocol SIEMENS

ANALOGO OUTPUTS

Type:	isolated, programmable with resolution of max.10 000 points, analog output corresponds with displayed data, type and range are adjustable
Non-linearity:	0,2% of range
TC:	100 ppm/°C
Rate:	response to change of value < 40 ms
Voltage:	0...2 V/5 V/10 V
Current:	0...5/20 mA/4...20 mA - compensation of conduct to 500 Ohm

MEASURED DATA RECORD

Type RTC:	time-controlled logging of measured data into instrument memory, allows to log up to 250 000 values
Type FAST:	fast data logging into instrument memory, allows to log up to 8 000 values at a rate of 40 records/s
Transmission:	via data output RS 232/485 or via OM Link

EXCITATION

Adjustable:	5...24 VDC/max. 1,2 W, isolated
-------------	---------------------------------

POWER SUPPLY

Options:	10...30 V AC/DC, 10 VA, isolated, - fuse inside (T 4000 mA) 80...250 V AC/DC, 10 VA, isolated - fuse inside (T 630 mA)
----------	---

MECHANIC PROPERTIES

Material:	Noryl GFN2 SE1, incombustible UL 94 V-I
Dimensions:	48 x 96 x 120 mm
Panel cut-out:	46 x 90,5 mm

OPERATING CONDITIONS

Connection:	connector terminal board, conductor cross-section <1,5 mm ² / <2,5 mm ²
Stabilisation period:	within 15 minutes after switch-on
Working temp.:	0°...60°C
Storage temp.:	-10°...85°C
Cover:	IP65 (front panel only)
Construction:	safety class I
Overvoltage category:	EN 61010-1, A2
Insulation resistance:	for pollution degree II, measurement category III AC instrum.power supply > 670 V (PI), 300 V (DI) DC instrum.power supply > 300 V (PI), 150 V (DI) Input/output > 300 V (PI), 150 (DI)
EMC:	EN 61000-3-2+A12; EN 61000-4-2, 3, 4, 5, 8, 11; EN 550222, A1, A2

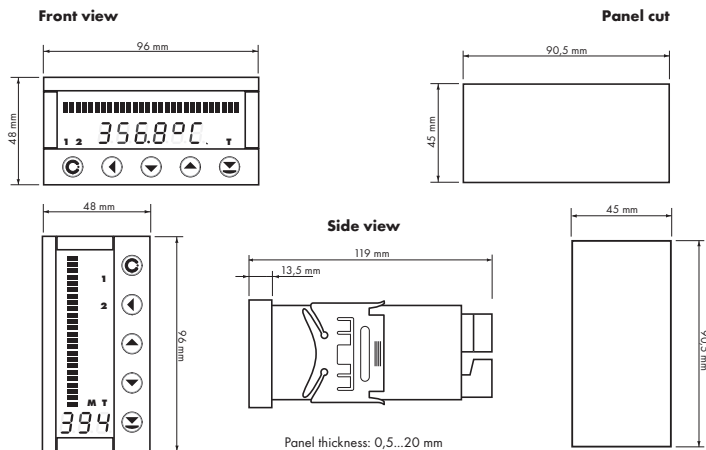

Instrument installation

1. insert the instrument into the panel cut-out
2. fit both travellers on the box
3. press the travellers close to the panel

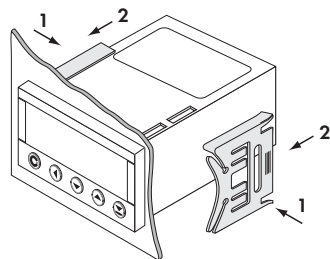
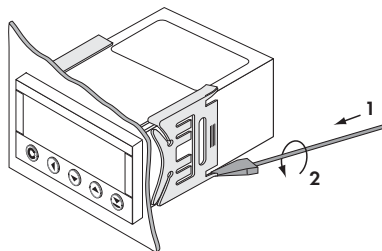

Instrument disassembly

1. slide a screw driver under the traveller wing
2. turn the screw driver and remove the traveller
3. take the instrument out of the panel

Product **OMB 412UNI** **A** **B**
 Type
 Manufacturing No.
 Date of sale

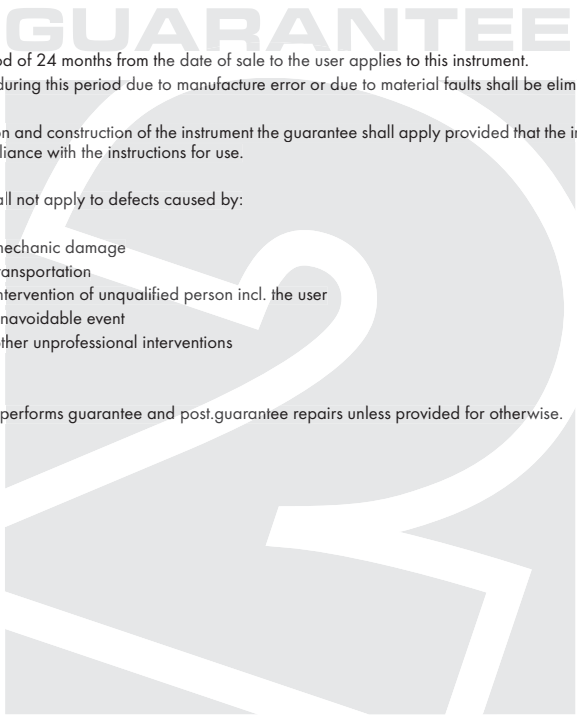

A guarantee period of 24 months from the date of sale to the user applies to this instrument.
 Defects occurring during this period due to manufacture error or due to material faults shall be eliminated free of charge.

For quality, function and construction of the instrument the guarantee shall apply provided that the instrument was connected and used in compliance with the instructions for use.

The guarantee shall not apply to defects caused by:

- mechanic damage
- transportation
- intervention of unqualified person incl. the user
- unavoidable event
- other unprofessional interventions

The manufacturer performs guarantee and post.guarantee repairs unless provided for otherwise.

Stamp, signature

DECLARATION OF CONFORMITY

Company: **ORBIT MERRET, spol. s r.o.**
Klánska 81/141, 142 00 Prague 4, Czech Republic, IDNo: 00551309

Manufactured: **ORBIT MERRET, spol. s r.o.**
Vodňanská 675/30, 198 00 Prague 9, Czech Republic

declares at its full responsibility that the product presented hereunder meets all technical requirements, is safe for use when utilised under the terms and conditions determined by ORBIT MERRET, spol.s r.o. and that our company has taken all measures to ensure conformity of all products of the type listed hereunder, which are being brought out to the market, with technical documentation and requirements of the appurtenant statutory orders.

Product: 4-digit programmable panel instrument

Type: **OMB 412**

Version: UNI, PWR

Conformity is assessed pursuant to the following standards:

El. safety:	EN 61010-1
EMC:	EN 50131-1, chapter 14 and chapter 15
	EN 50130-4, chapter 7
	EN 50130-4, chapter 8
	EN 50130-4, chapter 9
	EN 50130-4, chapter 10
	EN 50130-4, chapter 11
	EN 50130-4, chapter 12
	EN 50130-4, chapter 13
	EN 50130-5, chapter 20
	prEN 50131-2-1, par. 9.3.1
	EN 61000-4-8
	EN 61000-4-9
	EN 61000-3-2 ed. 2:2001
	EN 61000-3-3: 1997, Cor. 1:1998, Z1:2002
	EN 55022, chapter 5 and chapter 6

and Ordinance on:

El. safety:	No. 168/1997 Coll.
EMC:	No. 169/1997 Coll.

The evidence are the protocols of authorized and accredited organizations:

VTÚE Praha, experimental laboratory No. 1158, accredited by ČIA
VTÚPV Vyškov, experimental laboratory No. 1103, accredited by ČIA

Place and date of issue: Prague, 18. March 2006

Miroslav Hackl v.r.
Company representative

Mode of asses. of conformity §12, par. 4 b, d Act No. 22/1997 Coll.