

USER MANUAL

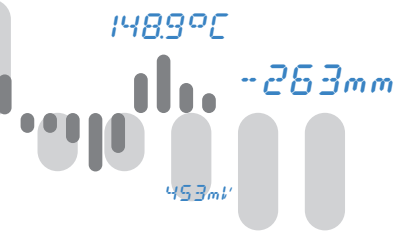

OMD 202UNI - A

4/6 DIGIT PROGRAMMABLE
LARGE DISPLAY
DC VOLTMETER/AMMETER
PROCESS MONITOR
OHMMETER
THERMOMETER FOR PT 100/500/1 000
THERMOMETER FOR NI 1 000
THERMOMETER FOR THERMOCOUPLES
DISPLAYS FOR LIN. POTENTIOMETERS

DIGITAL PANEL METERS

BARGRAPHS

LARGE DISPLAYS

TRANSMITTERS TO DIN RAIL

PAPERLESS RECORDERS

PLC

WARRANTY



SAFETY INSTRUCTIONS

Please read carefully the enclosed safety instructions and observe them!

Installation, all operational interventions, maintenance and service must be performed by a qualified personnel and in accordance with the attached information and safety regulations. The manufacturer is not liable for damage caused by improper installation, configuration, maintenance, and service.

The recorder must be installed according to the respective application. Incorrect installation can cause a malfunction, which can result in damage or accident.

The recorder uses dangerous voltages that can cause a fatal accident. Before you start solving problems (e.g. in case of failure or disassembly), the device must be disconnected from the power supply. For safety information the EN 61 010-1 + A2 standard must be observed.

When removing or inserting a card, observe the safety instructions and follow the recommended procedure. During any intervention the recorder must be disconnected from the power supply.

Do not attempt to repair or modify the device. A defective recorder must be sent for repair to the manufacturer.

These devices should be safeguarded by isolated or common fuses (breakers)!

The recorder is not designed for installation in potentially explosive surroundings (Ex). Use it only outside potentially explosive surroundings

TECHNICAL DATA

Measuring instruments of the OMD 202 series conform to the European regulation 2014/30/EU and 2014/35/EU

The instruments are up to the following European standards:

EN 61010-1 Electrical safety

EN 61326-1 Electronic measuring, control and laboratory devices – Requirements for EMC "Industrial use"

The recorders are applicable for unlimited use in agricultural and industrial areas.



ORBIT MERRET, spol. s r.o.
Vodnanska 675/30
198 00 Prague 9
Czech Republic

Tel: +420 - 281 040 200
Fax: +420 - 281 040 299
e-mail: orbit@merret.eu
www.orbit.merret.eu





| | | | |
|--|-----------|--|-----------|
| 1. CONTENTS | 3 | 6.2 "PROFI" menu - CHANNEL | |
| 2. INSTRUMENT DESCRIPTION | 4 | 6.2.1 Setting measuring parameters (projection, filters, decimal point, description) | 58 |
| 3. INSTRUMENT CONNECTION | 6 | 6.2.2 Setting mathematic functions | 61 |
| Measuring ranges..... | 6 | 6.2.3 Selection of evaluation of min/max. value .. | 63 |
| Termination of RS 485 communication line..... | 6 | 6.3 "PROFI" menu - OUTPUT | |
| Instrument connection..... | 7 | 6.3.1 Selection of excitation | 65 |
| Recommended connection of sensors | 8 | 6.3.2 Setting Limits | 65 |
| 4. INSTRUMENT SETTING | 10 | 6.3.3 Setting data output..... | 69 |
| Symbols used in the instructions | 12 | 6.3.4 Setting analog output..... | 69 |
| Setting the DP and the (-) sign | 12 | 6.3.5 Selection of display projection..... | 71 |
| Control keys function..... | 13 | 6.4 "PROFI" menu - SERVICE | |
| Setting/permitting items into "USER" menu..... | 13 | 6.4.1 Setting the address of IR remote control ... | 74 |
| 5. SETTING "LIGHT" MENU | 14 | 6.4.2 Selection of programming menu „LIGHT"/„PROFI" | 75 |
| 5.0 Description "LIGHT" menu | 15 | 6.4.3 Restoration manufacture setting | 76 |
| Setting input - Type "DC" | 18 | 6.4.4 Calibration - input range (DU)..... | 77 |
| Setting input - Type "PM" | 20 | 6.4.5 Selection of instr. menu language version .. | 77 |
| Setting input - Type "OHM"..... | 22 | 6.4.6 Setting new access password | 78 |
| Setting input - Type "RTD - Pt" | 24 | 6.4.7 Instrument identification | 78 |
| Setting input - Type "RTD - Ni" | 26 | 7. SETTING ITEMS INTO "USER" MENU | 80 |
| Setting input - Type "T/C" | 28 | 8. METHOD OF MEASURING OF THE COLD JUNCTION | 82 |
| Setting input - Type "DU" | 20 | 9. DATA PROTOCOL | 83 |
| Setting input - Type "RTD - Cu" | 32 | 10.ERROR STATEMENTS | 85 |
| Setting Limits..... | 34 | 11.TABLE OF SYMBOLS | 86 |
| Setting analog output | 36 | 12.INSTRUMENT DIMENSIONS AND INSTALATION ... | 87 |
| Setting display colors..... | 38 | 13.TECHNICAL DATA | 88 |
| Setting the address of IR remote control | 40 | 14.CERTIFICATE OF GUARANTEE | 90 |
| Selection of programming menu „LIGHT"/„PROFI" .. | 40 | DECLARATION OF CONFORMITY | 91 |
| Restoration of manufacture setting | 40 | | |
| Calibration - input range (DU)..... | 41 | | |
| Selection of instrument menu language version. ... | 42 | | |
| Setting new access password | 43 | | |
| Instrument identification | 43 | | |
| 6. SETTING "PROFI" MENU | 44 | | |
| 6.0 Description of "PROFI" menu | 44 | | |
| 6.1 "PROFI" menu - INPUT | 44 | | |
| 6.1.1 Resetting internal values | 48 | | |
| 6.1.2 Setting measuring type, range, mode, rate, ... | 49 | | |
| 6.1.3 Setting the Real Time | 53 | | |
| 6.1.4 External input function selection | 53 | | |
| 6.1.5 Optional accessory functions of the keys. ... | 54 | | |

2. INSTRUMENT DESCRIPTION

2.1 DESCRIPTION

The OMD 202 model series are 4/6 digit large panel programmable displays designed for maximum efficiency and user comfort while maintaining their favourable price. It comes either with a 3-colour LED display (red/green/orange) or with High Brightness LEDs (red or green with brightness of 1 300 mcd).

Type OMD 202UNI is a multifunction instrument with the option of configuration for 8 various input options, easily configurable in the instrument menu. By further options of input modules it is feasible to measure larger ranges of DC voltage and current or increase the number of inputs up to 4 (applies for PM).

The instrument is based on an 8-bit microcontroller with a multichannel 24-bit sigma-delta converter, which secures high accuracy, stability and easy operation of the instrument.

THE OMD 202 IS A MULTIFUNCTION INSTRUMENT AVAILABLE IN FOLLOWING TYPES AND RANGES

| | |
|----------------|---|
| UNI | DC: $\pm 60/\pm 150/\pm 300/\pm 1200$ mV |
| | PM: $0...5$ mA/ $0...20$ mA/ $4...20$ mA/ ± 2 V/ ± 5 V/ ± 10 V/ ± 40 V |
| | OHM: $0...100$ Ω / $0...1$ k Ω / $0...10$ k Ω / $0...100$ k Ω |
| | RTD-Pt: Pt 50/100/Pt 500/Pt 1 000 |
| | RTD-Cu: Cu 50/Cu 100 |
| | RTD-Ni: Ni 1 000/Ni 10 000 |
| | T/C: J/K/T/E/B/S/R/N/L |
| | DU: Linear potentiometer (min. 500 Ω) |
| UNI - A | DC: $\pm 0,1$ A/ $\pm 0,25$ A/ $\pm 0,5$ A/ ± 2 A/ ± 5 A/ ± 100 V/ ± 250 V/ ± 500 V |
| UNI - B | PM: $3 \times 0...5$ mA/ $0...20$ mA/ $4...20$ mA/ ± 2 V/ ± 5 V/ ± 10 V/ ± 40 V |

PROGRAMMABLE PROJECTION

| | |
|------------------|--|
| Selection: | of type of input and measuring range |
| Measuring range: | adjustable as fixed or with automatic change |
| Setting: | manual, optional projection on the display may be set in the menu for both limit values of the input signal , e.g. input $0...20$ mA > $0...850,0$ |
| Projection: | -9999...9999 (-99999...999999) |

COMPENSATION

| | |
|----------------------|--|
| of conduct: | in the menu it is possible to perform compensation for 2-wire connection |
| of conduct in probe: | internal connection (conduct resistance in measuring head) |
| of CJC (T/C): | manual or automatic, in the menu it is possible to perform selection of the type of thermocouple and compensation of cold junctions, which is adjustable or automatic(temperature at the brackets) |

LINEARIZATION

Linearization:* by linear interpolation in 50 points (solely via OM Link)

DIGITAL FILTERS

| | |
|-------------------|---|
| Floating average: | from 2...30 measurements |
| Exponen.average: | from 2...100 measurements |
| Rounding: | setting the projection step for display |

MATHEMATIC FUCTIONS

| | |
|------------------|--|
| Min/max. value: | registration of min./max. value reached during measurement |
| Tare: | designed to reset display upon non-zero input signal |
| Peak value: | the display shows only max. or min. value |
| Mat. operations: | polynome, 1/x, logarithm, exponential, power, root, sin x |

EXTERNAL CONTROL

| | |
|---------------|--|
| Lock: | control keys blocking |
| Hold: | display/instrument blocking |
| Tare: | tare activation/resetting tare to zero |
| Resetting MM: | resetting min/max value |

2.2 OPERATION

The instrument is set and controlled by IR Remote control. All programmable settings of the instrument are performed in three adjusting modes:

| | |
|--------------|--|
| LIGHT | Simple programming menu - contains solely items necessary for instrument setting and is protected by optional number code |
| PROFI | Complete programming menu - contains complete instrument menu and is protected by optional number code |
| USER | User programming menu - may contain arbitrary items selected from the programming menu (LIGHT/PROFI), which determine the right (see or change) - access without password |

All programmable parameters are stored in the EEPROM memory (they hold even after the instrument is switched off).

Complete instrument operation and setting may be performed via OM Link communication interface, which is a standard equipment of all instruments.

OMLINK The operation program is freely accessible (www.orbit.merret.cz) and the only requirement is the purchase of OML cable to connect the instrument to PC. It is manufactured in version RS 232 and USB and is compatible with all ORBIT MERRET instruments. Another option for connection is with the aid of data output RS 232 or RS 485 (without the need of the OML cable).

The program OM LINK in „Basic“ version will enable you to connect one instrument with the option of visualization and archiving in PC. The OM Link „Standard“ version has no limitation of the number of instruments connected.

2.3 OPTIONS

Excitation is suitable for supplying power to sensors and transmitters. It has a galvanic separation.

Comparators are assigned to monitor one, two, three or four limit values with relay output. The user may select limits regime: LIMIT/DOSING/FROM-TO. The limits have adjustable hysteresis within the full range of the display as well as selectable delay of the switch-on in the range of 0...99,9 s. Reaching the preset limits is signalled by LED and simultaneously by the switch-on of the relevant relay.

Data outputs are for their rate and accuracy suitable for transmission of the measured data for further projection or directly into the control systems. We offer an isolated RS232 and RS485 with the ASCII or DIN MessBus protocol.

Analog outputs will find their place in applications where further evaluating or processing of measured data is required in external devices. We offer universal analog output with the option of selection of the type of output - voltage/current. The value of analog output corresponds with the displayed data and its type and range are selectable in Menu.

3. INSTRUMENT CONNECTION

The instrument supply leads should not be in proximity of the incoming low-potential signals.

Contactors, motors with larger input power should not be in proximity of the instrument.

The leads into the instrument input (measured quantity) should be in sufficient distance from all power leads and appliances. Provided this cannot be secured it is necessary to use shielded leads with connection to ground (bracket E).

The instruments are tested in compliance with standards for use in industrial area, yet we recommend to abide by the above mentioned principles.

MEASURING RANGES

| TYPE | INPUT I | INPUT U |
|--------|-----------------------------------|-------------------------|
| DC | | 0...60/150/300/1 200 mV |
| PM | 0...5/20 mA/4...20 mA | ±2/±5/±10/±40 V |
| OHM | 0...100 Ω/1 kΩ/10 kΩ/100 kΩ | |
| RTD-Pt | Pt 50/100/Pt 500/ Pt 1 000 | |
| RTD-Cu | Cu 50/100 | |
| RTD-Ni | Ni 1 000/10 000 | |
| T/C | J/K/T/E/B/S/R/N/L | |
| DU | Linear potentiometer (min. 500 Ω) | |

OPTION "A"

| TYPE | INPUT I | INPUT U |
|------|--|---------------------------------|
| DC | ±0,1 A/±0,25 A/±0,5 A to GND (C) ±2 A/±5 A to GND (B) | ±100 V/±250 V/±500 V to GND (C) |

OPTION "B"

| TYPR | INPUTS 2, 3, 4/I | INPUTS 2, 3, 4/U |
|------|-----------------------|------------------|
| PM | 0...5/20 mA/4...20 mA | ±2/±5/±10/±40 V |

Termination of RS 485 communication line

X3 - Termination of communication line RS 485

| Full | Significance | Default | Recommendation |
|------|-----------------------------|-------------------|---|
| 1-2 | connect L+ to (+) source | terminalconnected | connect at the end of line do not disconnect |
| 3-4 | termination of line 120 Ohm | disconnected | |
| 5-6 | connect L- to (-) source | terminalconnected | |

RS 485 line should have a linear structure - wires (ideally shielded and twisted) should lead from one device to another.

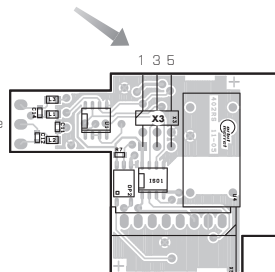

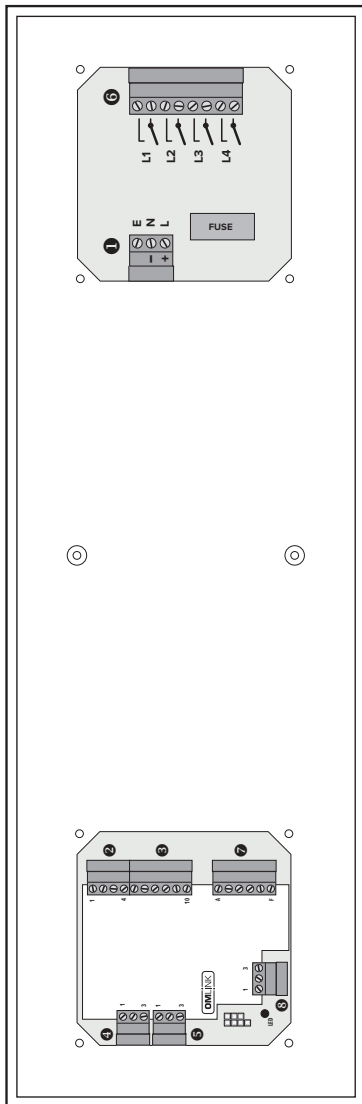

- 4 Analogue output***
 - 1 AO-U
 - 2 AO-L
 - 3 AO-1
 - 4 GND
- 5 Data output***
 - 1 DO-U
 - 2 DO-L
 - 3 DO-1
 - 4 GND
- 6 Relays***
 - 1 L1
 - 2 L2
 - 3 L3
 - 4 L4
- 2 External inputs**
 - 1 EXT-1
 - 2 EXT-2
 - 3 EXT-3
- 3 Input**
 - 1 DC PM
 - 2 EXCITATION
 - 3 GND
 - 4 INPUT-1
 - 5 INPUT-U
- 7 Input***
 - 1 INPUT-1
 - 2 GND-1/5
 - 3 GND-U/10/5
 - 4 INPUT-U

Maximum of 250 mA may be connected to "INPUT - I" (bracket no. 8), i.e. 10-times range overload.
Mind the correct connection/mistaking of current - voltage input.
Destruction of measuring resistance in current input (15R) may occur.



3. INSTRUMENT CONNECTION

Example connection of a 2-wire sensor with current signal output powered by instrument's excitation

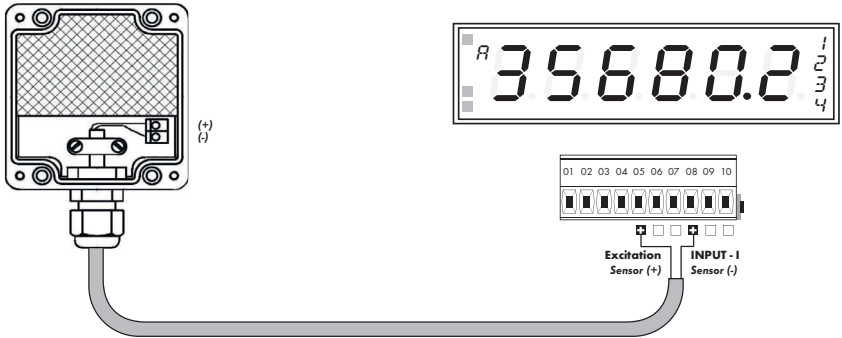

Example connection of a 3-wire sensor with current signal output powered by instrument's excitation

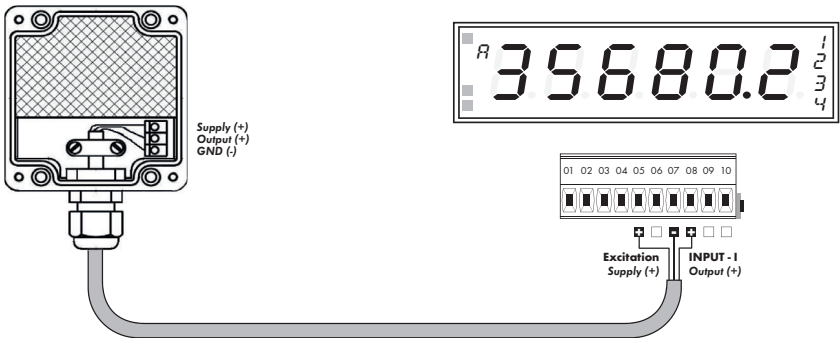



Example connection of 3-wire sensor with voltage signal output powered by instrument's excitation

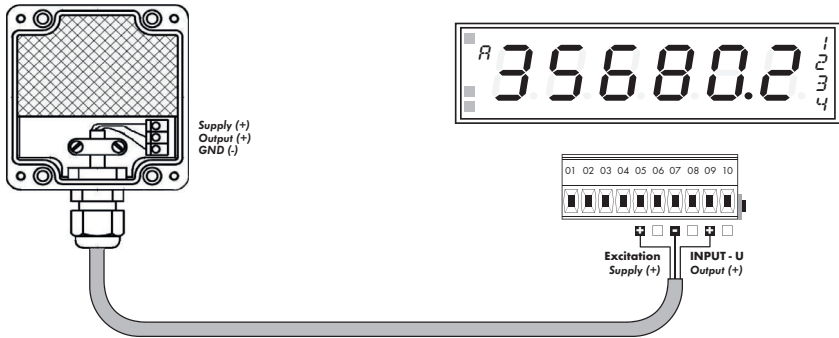

Example connection of resistance measurement using 4 wires

By connecting resistor R* we eliminate error message E. I.O.V. (input overflow) when the measured resistance is disconnected

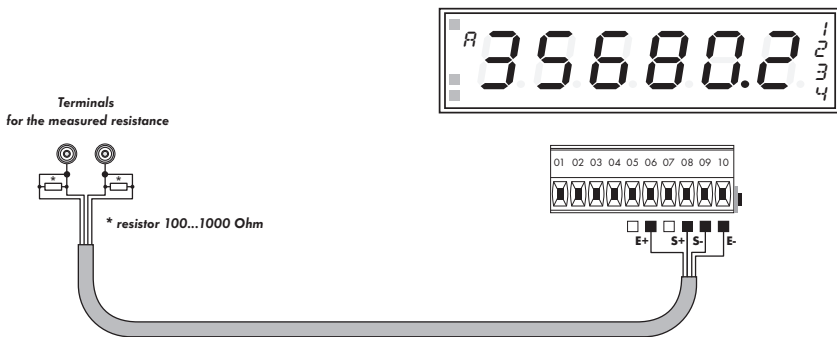

SETTING PROFI

For expert users

Complete instrument menu

Access is password protected

Possibility to arrange items of the **USER MENU**

Tree menu structure

SETTING LIGHT

For trained users

Only items necessary for instrument setting

Access is password protected

Possibility to arrange items of the **USER MENU**

Linear menu structure

SETTING USER

For user operation

Menu items are set by the user (Profi/Light) as per request

Access is not password protected

Optional menu structure either tree (PROFI) or linear (LIGHT)

4.1 SETTING

The instrument is set and controlled by IR Remote control. All programmable settings of the instrument are performed in three adjusting modes:

- LIGHT** **Simple programming menu**
 - contains solely items necessary for instrument setting and is protected by optional number code
- PROFI** **Complete programming menu**
 - contains complete instrument menu and is protected by optional number code
- USER** **User programming menu**
 - may contain arbitrary items selected from the programming menu (LIGHT/PROFI), which determine the right (see or change)
 - access without password

Complete instrument operation and setting may be performed via OM Link communication interface, which is a standard equipment of all instruments.

The operation program is freely accessible (www.orbit.merret.cz) and the only requirement is the purchase of OML cable to connect the instrument to PC. It is manufactured in version RS 232 and USB and is compatible with all ORBIT MERRET instruments. Another option for connection is with the aid of data output RS 232 or RS 485 (without the need of the OML cable).

Scheme of processing the measured signal

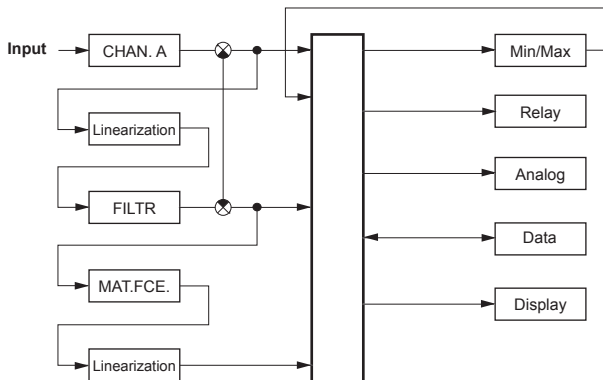

4. INSTRUMENT SETTING

Setting and controlling the instrument is performed by means of the Remote control. With the aid of the Remote control it is possible to browse through the operation menu and to select and set the required values.

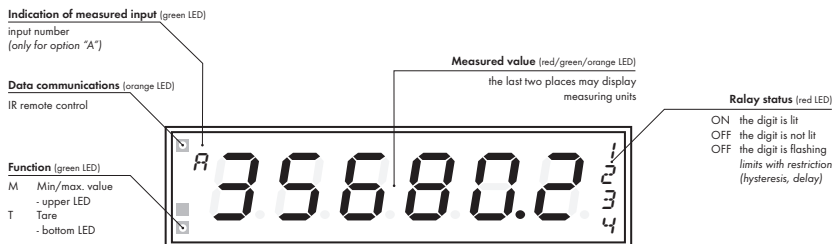

Symbols used in the instructions



DU OHM RTD T/C Indicates the setting for given type of instrument

DEF values preset from manufacture

symbol indicates a flashing light (symbol)

inverted triangle indicates the item that can be placed in USER menu

broken line indicates a dynamic item, i.e. it is displayed only in particular selection/version

after pressing the key the set value will not be stored

after pressing the key the set value will be stored

30 continues on page 30

Setting the decimal point and the minus sign











DECIMAL POINT

Its selection in the menu, upon modification of the number to be adjusted it is performed by the control key with transition beyond the highest decade, when the decimal point starts flashing . Positioning is performed by .

THE MINUS SIGN

Setting the minus sign is performed by the key on higher decade. When editing the item subtraction must be made from the current number (e.g.: 013 > , on class 100 > -87)

Control keys functions

| KEY | MEASUREMENT | MENU | SETTING NUMBERS/SELECTION |
|---|---|--|---------------------------|
|  | access into USER menu | exit menu | quit editing |
|  | programmable key function | back to previous level | move to higher decade* |
|  | programmable key function | move to previous item | move down* |
|  | programmable key function | move to next item | move up* |
|  | programmable key function | confirm selection | confirm setting/selection |
|  | access into LIGHT/PROFI menu | | |
| >3 s  | direct access into PROFI menu | | |
|  | | configuration of an item for "USER" menu | |
|  | | determine the sequence of items in "USER - LIGHT" menu | |
|  | cancelation of address instrument/remote controller | | |

* alternatively, the setting may be done from the numeric keys of the remote control by selecting directly the number required

Setting items into „USER" menu

- in **LIGHT** or **PROFI** menu
- no items permitted in **USER** menu from manufacture
- on items marked by inverted triangle

USER

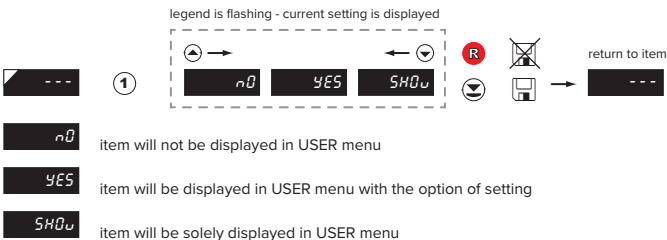

SETTING LIGHT

For trained users

Only items necessary for instrument setting

Access is password protected

Possibility to arrange items of the **USER MENU**

Linear menu structure

Preset from manufacture

| | |
|-------------------|------------|
| Password | "0" |
| Menu | LIGHT |
| USER menu | off |
| Setting the items | DEF |

1489°C -263mm

Access password
 1428 **C** PASSW **0**

Type of instruments
 TYPE **PN** Measuring range
 MODE 4-20mA

RTD OHM
 COEFF **2-wire** FDR **0000.0**

T/C
 COEFF **EMF: 1k** C.W.TEM **23** FDR **0000.0**

DC PM OHM DU
 PIN **0** PARAM **100** FDR **0000.0**

Selecting projection and connection

LIN.L1 20 **LIN.L2** 40 **LIN.L3** 60 **LIN.L4** 80
 Option - comparator

TYPE A.D. 4-20mA **PIN A.D.** 0 **PARAM A.D.** 100
 Option - Analog output

Primary color **COL.0** GREEN **First color limit** d15.L1 33.33 **Color beyond first limit** COL.1 ORANGE **Second color limit** d15.L2 66.67

Color beyond second limit COL.2 red **Remote controller address** Adr. Ir 0

Menu type MENU LIGHT **Return to manuf. calibration** rE.CAL YES **Return to manufacture setting** rE.SET TYPE

Calibration - only for "DU"
C.PIN YES **C.PARAM** YES

Language selection **L.ANG.** ENGL **New password** PAS.L1 0 **Identification** IdEnt YES **Type instrument** 0Nd 202Un.1 **SW version** 78-001 **Input** PN

Return to measuring mode
 1428

Upon delay exceeding 60s the programming mode is automatically discontinued and the instrument itself restores the measuring mode

5. SETTING LIGHT

1428



PASSu



0

Entering access password for access into the menu



PASSu Access into instrument menu

PAS = 0
 - access into menu is unrestricted, after releasing keys you automaticaly move to first item of the menu

PAS > 0
 - access into menu is protected ny number code

Set "Password" = 42 Example

TYPE



← →

dC PM OHM rtd-Pt rtd-ni TC

DU rtd-Cu



TYPE Selection of the type of instrument

- primary selection of the type of instrument
- performs default setting **DEF** of values from manufacture, incl. calibration

| Menu | Type of instrument |
|--------|--------------------------------|
| DC | DC voltmeter |
| PM | Process monitor |
| OHM | Ohmmeter |
| RTD-Pt | Thermometer for sensors Pt |
| RTD-Ni | Thermometer for sensors Ni |
| TC | Thermometer for thermocouples |
| DU | Display for lin. potentiometer |
| RTD-Cu | Thermometer for sensors Cu |

Type "PM" Example

| | |
|---------------|----|
| Type „DC“ | 18 |
| Type "PM" | 20 |
| Type "OHM" | 22 |
| Type "RTD-Pt" | 24 |
| Type "RTD-Ni" | 26 |
| Type "T/C" | 28 |
| Type "DU" | 30 |
| Type "RTD-Cu" | 32 |



SETTING LIGHT 5.

5. SETTING LIGHT

MEASURING MODE > DC



nDdE Selection of the instrument measuring range

DEF = 60 mV

DEF = 500 V*

* only for option "A"

| Menu | Measuring range |
|--------|-----------------|
| 60 mV | ±60 mV |
| 150 mV | ±150 mV |
| 300 mV | ±300 mV |
| 1200mV | ±1,2 V |
| 100 V | ±100 V |
| 250 V | ±250 V |
| 500 V | ±500 V |
| 0,10 A | ±0,1 A |
| 0,25 A | ±0,25 A |
| 0,50 A | ±0,5 A |
| 1,00 A | ±1 A |
| 5,00 A | ±5 A |

Range ±150 mV Example

60 nV 150 nV n1n A



n1n A Setting display projection for minimum value of input signal

- range of the setting is -99999...999999
- position of the DP does not affect display projection

- the DP is automatically shifted after the value is confirmed

DEF = 0

Projection for 0 mV > MIN A = 0 Example

0 n1n A



MAX A **Setting display projection for maximum value of input signal** - the DP is automatically shifted after the value is confirmed

- range of the setting is -99999...999999
- position of the DP does not affect display projection

DEF = 100

Projection for 150 mV > MAX A = 3500 Example

| | | | | | |
|-----|-----|-----|-----|-----|-----|
| 100 | 100 | 100 | 300 | 300 | 400 |
| 500 | 500 | 500 | 500 | 500 | 500 |

FD-0.A

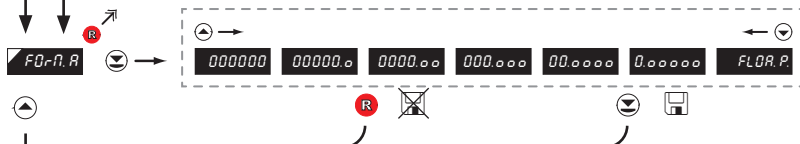

FD-0.A **Setting projection of the decimal point** **DEF** = 0000.00

- positioning of the DP is set here in the measuring mode

Projection of DP on display > 00000.0 Example

| | | |
|---------|---------|-------|
| 0000.00 | 00000.0 | COL 0 |
|---------|---------|-------|

*subsequent item on the menu depends on instrument equipment

5. SETTING LIGHT

MEASURING MODE > PM

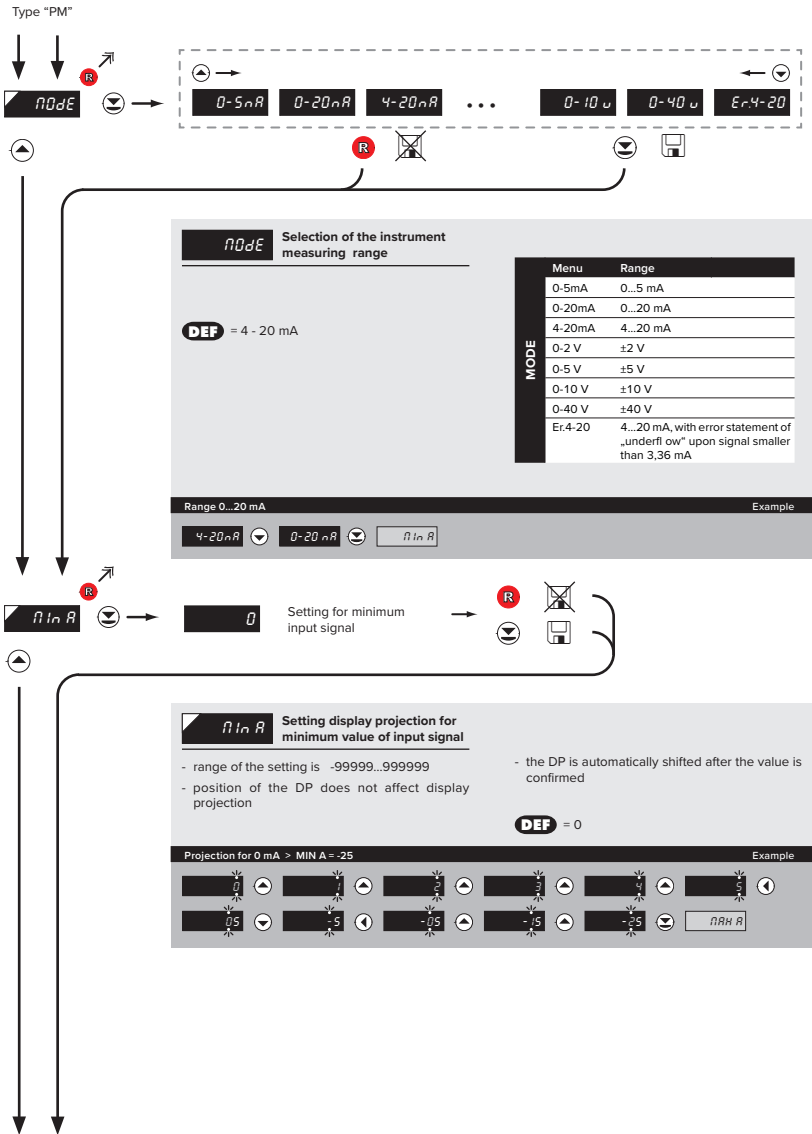



MAX A **Setting display projection for maximum value of input signal** - the DP is automatically shifted after the value is confirmed

- range of the setting is -99999...999999
- position of the DP does not affect display projection

DEF = 100

Projection for 20 mA → MAX A = 2500 Example

| | | | | | |
|-----|------|-----|------|--------|-----|
| 100 | 100 | 100 | 200 | 300 | 400 |
| 500 | 0500 | 500 | 2500 | F0-r.A | |

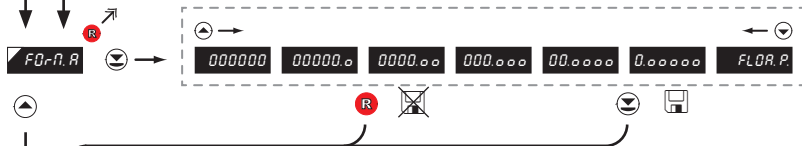

F0-r.A **Setting projection of the decimal point** **DEF** = 0000.00

- positioning of the DP is set here in the measuring mode

Projection of DP on display → 00000.0 Example

| | | | |
|---------|---------|--------|--|
| 0000.00 | 00000.0 | 000.00 | *subsequent item on the menu depends on instrument equipment |
|---------|---------|--------|--|

5. SETTING LIGHT

MEASURING MODE > OHM

Type "OHM"

The diagram shows a sequence of menu screens for setting the instrument. It starts with the 'OHM' mode, then moves to 'SELECTION OF INSTRUMENT MEASURING RANGE', then 'SELECTION OF THE TYPE OF SENSOR CONNECTION', and finally 'SETTING FOR MINIMUM INPUT SIGNAL'. Each screen shows the current setting and a table of available options. The 'DEF' (default) value is indicated for each setting.

SELECTION OF INSTRUMENT MEASURING RANGE

DEF = 100 Ω

| Menu | Range |
|-------|------------|
| 100 R | 0...100 Ω |
| 1 k | 0...1 kΩ |
| 10 k | 0...10 kΩ |
| 100 k | 0...100 kΩ |

Range 0...10 kΩ Example

SELECTION OF THE TYPE OF SENSOR CONNECTION

DEF = 2-WIRE

| Menu | Connection |
|--------|------------|
| 2-WIRE | 2-wire |
| 3-WIRE | 3-wire |
| 4-WIRE | 4-wire |

Type of connection - 3 wire > CONECT. = 3-WIRE Example

SETTING FOR MINIMUM INPUT SIGNAL

Setting display projection for minimum value of input signal

DEF = 0

Projection for 0 Ohm > MIN A = 0 Example

- the DP is automatically shifted after the value is confirmed



MAX A Setting display projection for maximum value of input signal

- range of the setting is -99999...999999
- position of the DP does not affect display projection

DEF = 100

Projection for 10 kOhm > MAX A = 10000 Example

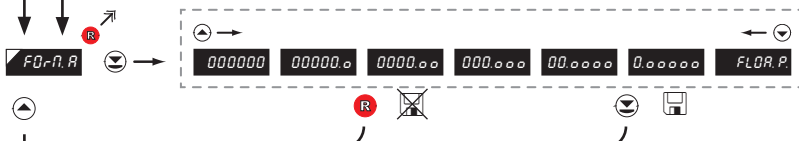

FO-r.R Setting projection of the decimal point

- positioning of the DP is set here in the measuring mode

DEF = 0000.00

Projection of DP on display > 00000.0 Example

*subsequent item on the menu depends on instrument equipment

5. SETTING LIGHT

MEASURING MODE > RTD-Pt

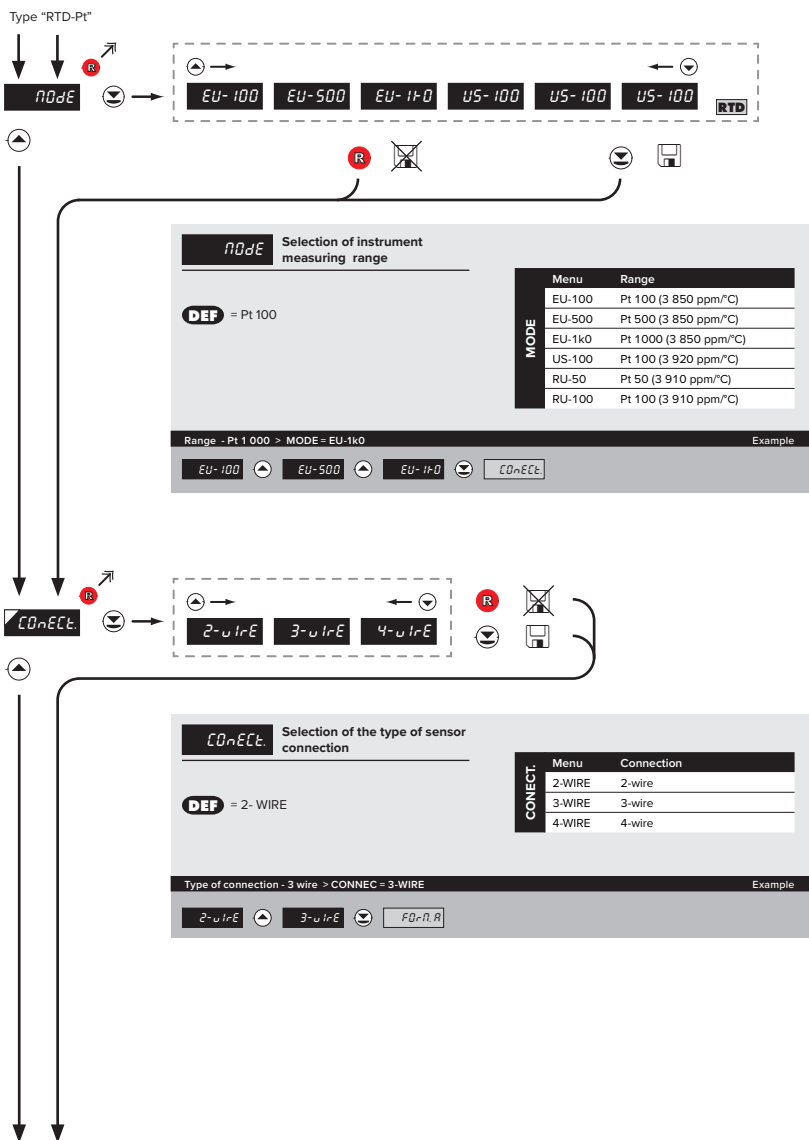



FD-R.A Setting projection of the decimal point

DEF = 00000.0

- positioning of the DP is set here in the measuring mode

Projection of DP on display > 000000 Example

| | | |
|---------|--------|-------|
| 00000.0 | 000000 | COL 0 |
|---------|--------|-------|

*subsequent item on the menu depends on instrument equipment

5. SETTING LIGHT

MEASURING MODE > RTD-Ni

Type "RTD-Ni"

RTD-E

5.0-1k 6.2-1k 5.0-10k 6.2-10k

⏪ ⏩

⏴ ⏵

⏶ ⏷

⏸

⏹

RTD-E Selection of instrument measuring range

DEF = Ni 1 000 - 5 000 ppm/C

| MODE | Menu | Range |
|------|---------|-------------------------|
| | 5.0-1k | Ni 1 000 (5 000 ppm/C) |
| | 6.2-1k | Ni 1 000 (6 180 ppm/C) |
| | 5.0-10k | Ni 10 000 (5 000 ppm/C) |
| | 6.2-10k | Ni 10 000 (6 180 ppm/C) |

Range - Pt 1 000 > MODE = EU-1k0 Example

EU-100 ⏴ EU-500 ⏴ EU-1k0 ⏵ CON-ECL

CON-ECL

2-wire 3-wire 4-wire

⏪ ⏩

⏴ ⏵

⏶ ⏷

⏸

⏹

CON-ECL Selection of the type of sensor connection

DEF = 2- WIRE

| CONNECT | Menu | Connection |
|---------|--------|------------|
| | 2-WIRE | 2-wire |
| | 3-WIRE | 3-wire |
| | 4-WIRE | 4-wire |

Type of connection - 3 wire > CONNEC = 3-WIRE Example

2-wire ⏴ 3-wire ⏵ FOR-R

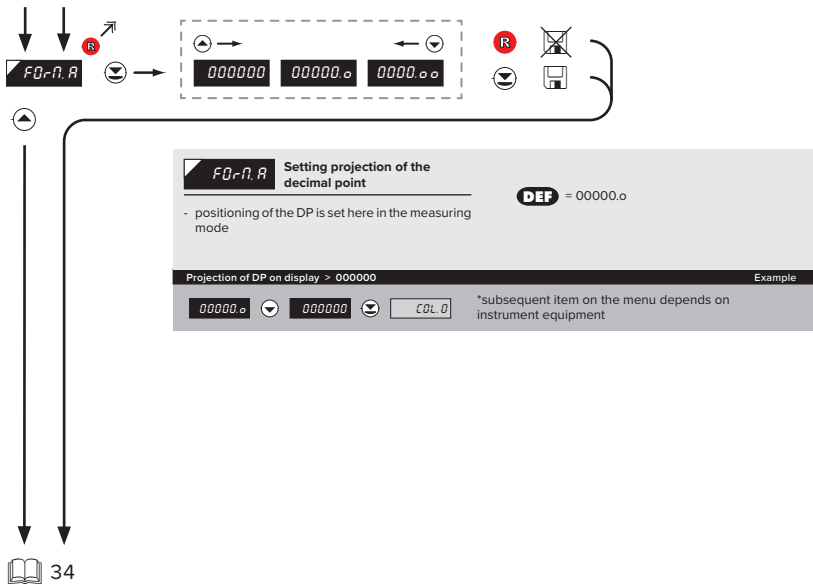

5. SETTING LIGHT

MEASURING MODE > T/C

Type "T/C"

nDdE

Selection of the type of thermocouple

- setting the input range depends on the measuring range ordered

DEF = Type "J"

| Menu | Type of thermocouple |
|-------|----------------------|
| T/C B | B |
| T/C E | E |
| T/C J | J |
| T/C K | K |
| T/C N | N |
| T/C R | R |
| T/C S | S |
| T/C T | T |
| T/C L | L |

Type of thermocouple "K"

Example

COndEct

Selection of the type of sensor connection

DEF = EXT. 1TC

| Menu | Connection | Ref. T/C |
|---------|---|----------|
| INT.1TC | measuring C.J. at instrument brackets | × |
| INT.2TC | measuring C. J. at instrument brackets with anti-series connected ref. TC | ✓ |
| EXT.1TC | the entire measuring set is working under invaried and constant temperature | × |
| EXT.2TC | when using compensation box | ✓ |

Type of connection > CONNECT. = EXT. 2TC

Example

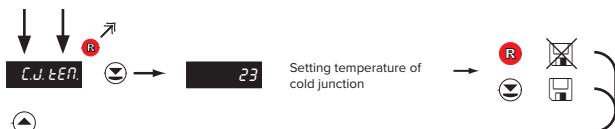

C.J. TEM. Setting temperature of cold junction

- range 0...99°C with compensation box

DEF = 23

Setting temperature of cold junction > C.J. TEM. = 35 Example

23 24 25 25 35 F0-r.R



F0-r.R Setting projection of the decimal point

- positioning of the DP is set here in the measuring mode

DEF = 00000.0

Projection of DP on display > 000000 Example

00000.0 000000 COL.D

*subsequent item on the menu depends on instrument equipment

!
For thermocouple type "B" the items CONECT. and C.J. TEM. are not available

!
Method and procedure of setting the cold junctions is described in separate chapter on page 80

5. SETTING LIGHT

MEASURING MODE > DU

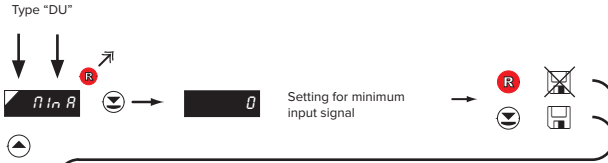

min R Setting display projection for minimum value of input signal

- the DP is automatically shifted after the value is confirmed
- range of the setting is -99999...999999
- position of the DP does not affect display projection

DEF = 0

Projection for the beginning > MIN A = 0 Example

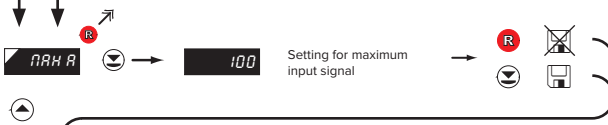

max R Setting display projection for maximum value of input signal

- the DP is automatically shifted after the value is confirmed
- range of the setting is -99999...999999
- position of the DP does not affect display projection

DEF = 100

Projection for the end > MAX A = 5000 Example

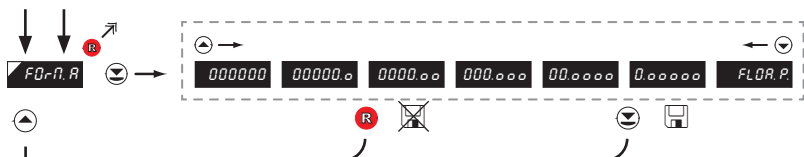

F0r.A.R **Setting projection of the decimal point** **DEF** = 0000.00

- positioning of the DP is set here in the measuring mode

Projection of DP on display > 0000.00 Example

| | | | |
|---------|---|-------|--|
| 0000.00 | ▼ | COL 0 | *subsequent item on the menu depends on instrument equipment |
|---------|---|-------|--|

34

Calibration of the beginning and the end of range of linear potentiometer is on page 41

5. SETTING LIGHT

MEASURING MODE > RTD-Cu

Type "RTD-Cu"

noDE

428-50 428-0.1 426-50 426-0.1



noDE Selection of instrument measuring range

DEF = Cu 50/4 280 ppm

| MODE | Menu | Range |
|------|---------|-----------------------|
| | 428-50 | Cu 50 (4 285 ppm/°C) |
| | 428-100 | Cu 100 (4 285 ppm/°C) |
| | 426-50 | Cu 50 (4 260 ppm/°C) |
| | 426-100 | Cu 100 (4 260 ppm/°C) |

Range - Cu-50/4 260 ppm > MODE = 426-50 Example

428-50 428-0.1 426-50 CONECT



CONECT

2-wire 3-wire 4-wire



CONECT Selection of the type of sensor connection

DEF = 2- WIRE

| CONNECT | Menu | Connection |
|---------|--------|------------|
| | 2-WIRE | 2-wire |
| | 3-WIRE | 3-wire |
| | 4-WIRE | 4-wire |

Type of connection - 3 wire > CONNEC = 3-WIRE Example

2-wire 3-wire F0-R.R



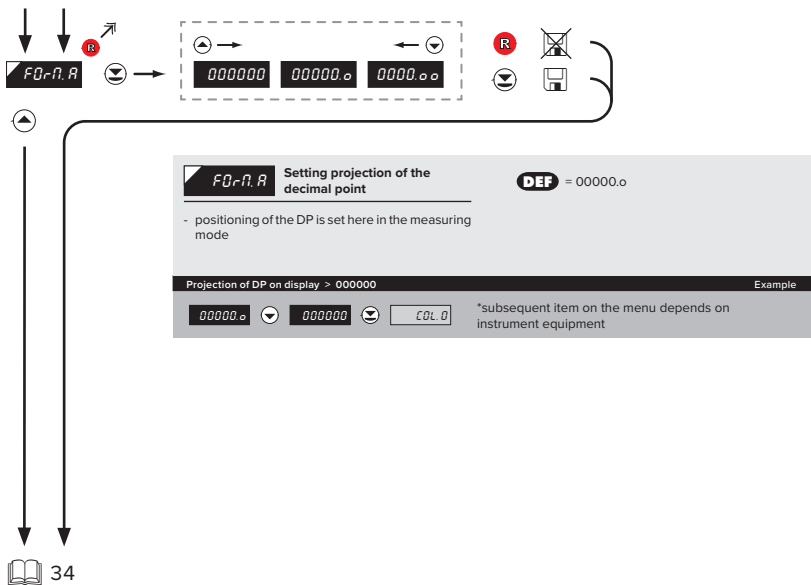

5. SETTING LIGHT

DISPLAYED ONLY WITH OPTIONS > COMPARATORS

The diagram illustrates the process of setting limits L1 and L2. It starts with physical button icons: a left arrow, a right arrow, a red 'R' button, and a 'PROF' button. Arrows indicate the flow from these buttons to the 'Setting boundary for limit 1' screen, which shows '20'. A red 'R' button and a 'PROF' button are also shown next to this screen.

The 'Setting boundary for limit 1' screen displays the following information:

- LIM L.1** Setting boundary for limit 1
- range of the setting is -99999...999999
- contingent modification of hysteresis or delay may be performed in "PROFI" menu
- DEF** = 20
- DEF** „Hysteresis“=0, „Delay“=0

An example menu for 'Setting limit 1 > L 1 = 32' is shown below, with a 'COL D' button. The menu items are: 20, 21, 22, 32, 32, COL D.

The process then moves to 'Setting boundary for limit 2', which shows '40'. A red 'R' button and a 'PROF' button are also shown next to this screen.

The 'Setting boundary for limit 2' screen displays the following information:

- LIM L.2** Setting boundary for limit 2
- range of the setting is -99999...999999
- contingent modification of hysteresis or delay may be performed in "PROFI" menu
- DEF** = 40
- DEF** „Hysteresis“=0, „Delay“=0

An example menu for 'Setting limit 2 > L 2 = 53.1' is shown below, with a 'COL D' button. The menu items are: 40, 41, 41, 53.1, 53.1, 53.1, 23.1, 33.1, 43.1, 53.1, 0053.1, 0053.1, 0053.1, COL D. A note states: "* subsequent item on the menu depends on instrument equipment".

A warning box at the bottom right contains the following text:

!
Items for "Limits" and "Analog output" are accessible only if incorporated in the instrument.

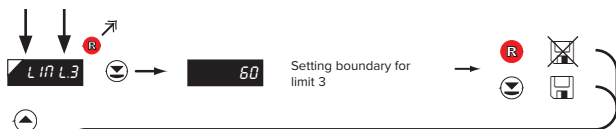

LIN L3 Setting boundary for limit 3

- range of the setting is -99999...999999
- contingent modification of hysteresis or delay may be performed in "PROFI" menu

DEF = 60
DEF „Hysteresis“=0, „Delay“=0

Setting limit 3 > L 3 = 85 Example

| | | | | | |
|----|----|----|-------|--|----|
| 60 | 61 | 62 | 63 | 64 | 65 |
| 65 | 75 | 85 | COL D | *subsequent item on the menu depends in instrument equipment | |



LIN L4 Setting boundary for limit 4

- range of the setting is -99999...999999
- contingent modification of hysteresis or delay may be performed in "PROFI" menu

DEF = 80
DEF „Hysteresis“=0, „Delay“=0

Setting limit 4 > L 4 = 103 Example

| | | | | | |
|----|-----|-----|-------|--|----|
| 80 | 81 | 82 | 83 | 84 | 85 |
| 93 | 003 | 003 | COL D | *subsequent item on the menu depends on instrument equipment | |

DISPLAYED ONLY WITH OPTIONS > COMPARATORS

5. SETTING LIGHT

DISPLAYED ONLY WITH OPTIONS > ANALOG OUTPUT

The diagram illustrates the navigation path for setting the analog output. It starts from the main menu where 'TYP. A.O.' and 'MIN. A.O.' are highlighted. Arrows indicate the sequence of screens visited: first 'Setting the type of analog output', then 'Assigning the display value to the beginning of the AO range', and finally the 'Example' screen for the second setting.

Navigation menu showing options: 0-20 mA, Er. 4-E, 4-20 E, ..., 0-5 V, 0-10 V, +10 V.

TYP. A.O. Setting the type of analog output

| Menu | Range | Description |
|-----------|-----------|--|
| 0-20mA | 0...20 mA | |
| Er. 4- T | 4...20 mA | signaling interrupted current loop and displaying an error message (<3.6 mA) |
| 4-20T | 4...20 mA | signaling broken current loop (<3.6 mA) |
| Er.4-20mA | 4...20 mA | with indication of error statement (<3.6 mA) |
| 4-20mA | 4...20 mA | |
| 0-5mA | 0...5 mA | |
| 0-2 V | 0...2 V | |
| 0-5 V | 0...5 V | |
| 0-10 V | 0...10 V | |
| +10 V | ±10 V | |

DEF = 4...20 mA

Type of analog output - 0...10 V > TYP. A.O. = 0-10 V Example

4-20 mA | 0-5 mA | 0-2 V | 0-5 V | 0-10 V | MIN A.O.

MIN. A.O. Assigning the display value to the beginning of the AO range

- range of the setting is -99999...999999

DEF = 0

Display value for the beginning of the AO range > MIN A.O. = 0 Example

0 | MIN A.O.

! Items for "Limits" and "Analog output" are accessible only if incorporated in the instrument.

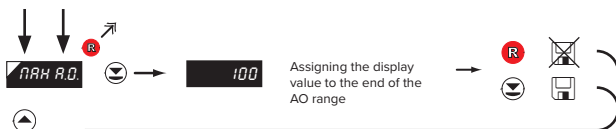

ARR A.O. Assigning the display value to the end of the AO range

- range of the setting is -99999...999999

DEF = 100

Display value for the end of the AO range > MAX A.O. = 120 Example

100

100

110

120

C.O.L.O

DISPLAYED ONLY WITH OPTIONS > ANALOG OUTPUT

5. SETTING LIGHT

APPLICABLE ONLY TO 3-COLOUR DISPLAY

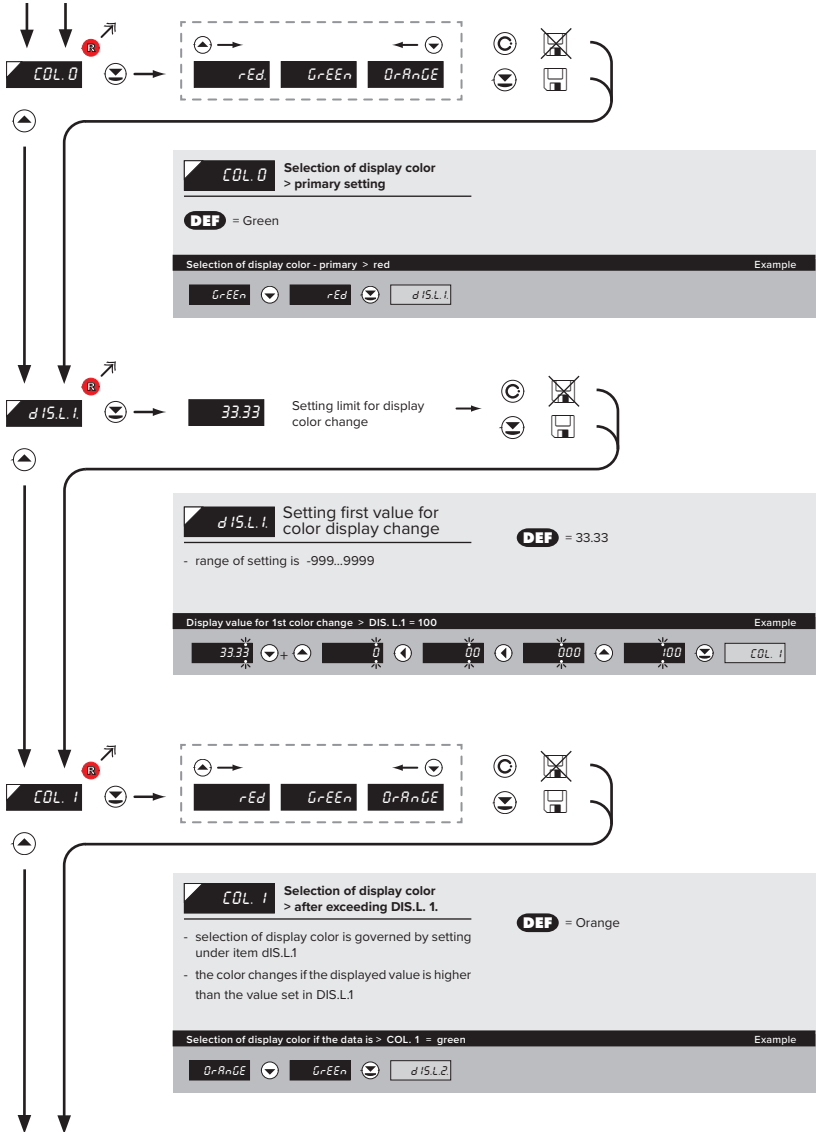

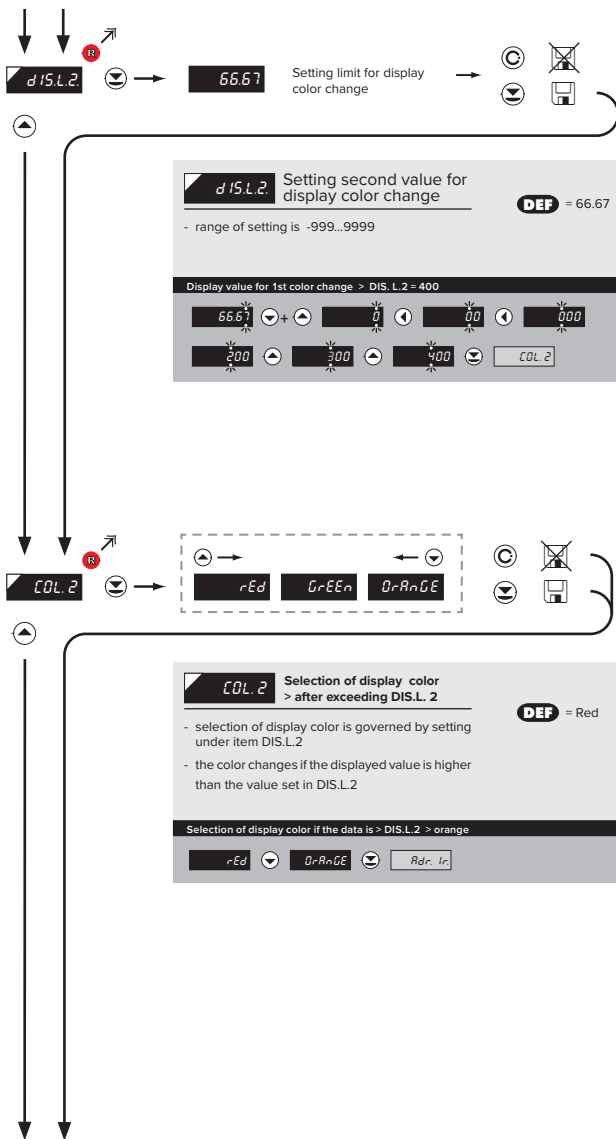

APPLICABLE ONLY TO 3-COLOUR DISPLAY

5. SETTING LIGHT

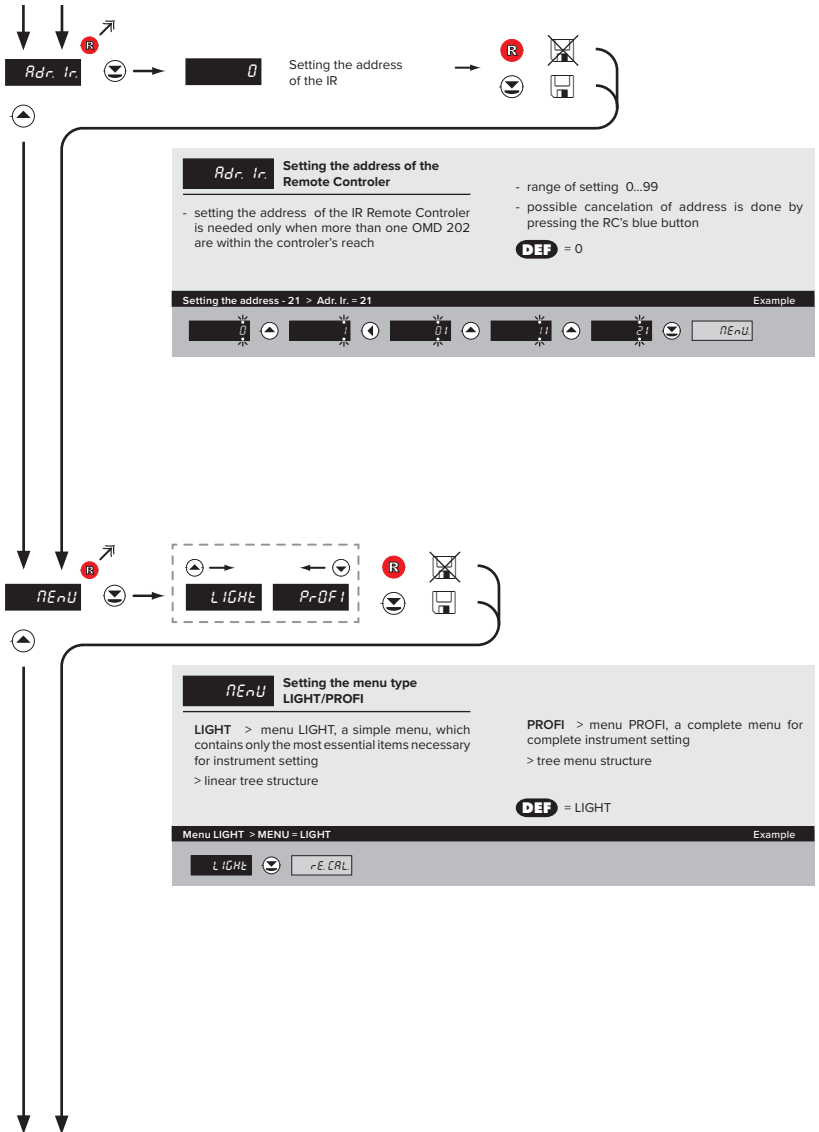

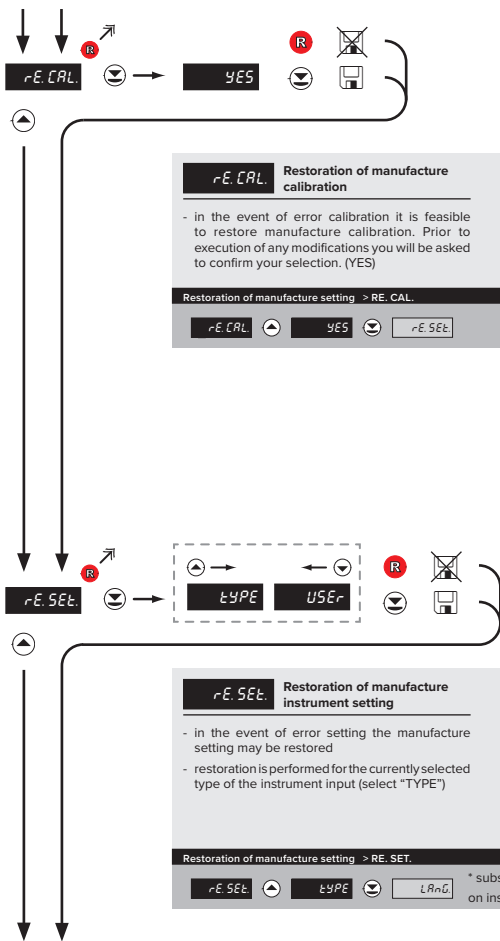

rE.CAL. Restoration of manufacture calibration

- in the event of error calibration it is feasible to restore manufacture calibration. Prior to execution of any modifications you will be asked to confirm your selection. (YES)

Restoration of manufacture setting > RE.CAL. Example

rE.CAL. YES

rE.SET. Restoration of manufacture instrument setting

- in the event of error setting the manufacture setting may be restored
- restoration is performed for the currently selected type of the instrument input (select "TYPE")
- provided you stored your user setting in the "PROFI" menu, it may also be restored (select "USER")
- loading manufacture calibration and primary setting of items on the menu (DEF)

Restoration of manufacture setting > RE.SET. Example

rE.SET. TYPE USER

* subsequent item on the menu depends on instrument type, for "DU" > "C. MIN"

| | |
|---------------|----|
| Type „DC“ | 43 |
| Type "PM" | 43 |
| Type "OHM" | 43 |
| Type "RTD-Pt" | 43 |
| Type "RTD-Ni" | 43 |
| Type "T/C" | 43 |
| Type "DU" | 42 |
| Type "RTD-Cu" | 43 |

5. SETTING LIGHT

MEASURING MODE > DU

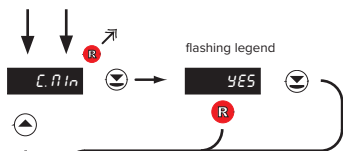

C. MIN Calibration of input range - the potentiometer traveller in initial position Only for type "DU"

- prior confirming the flashing "YES" sign the potentiometer traveller has to be in given idle position

Calibration of the beginning of the range > C. MIN

Example

YES

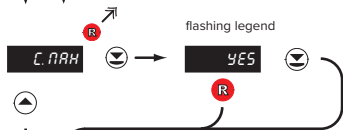

C. MAX Calibration of input range - the potentiometer traveller in end position Only for type "DU"

- prior confirming the flashing "YES" sign the potentiometer traveller has to be in given idle position

Calibration of the end of the range > C. MAX

Example

YES

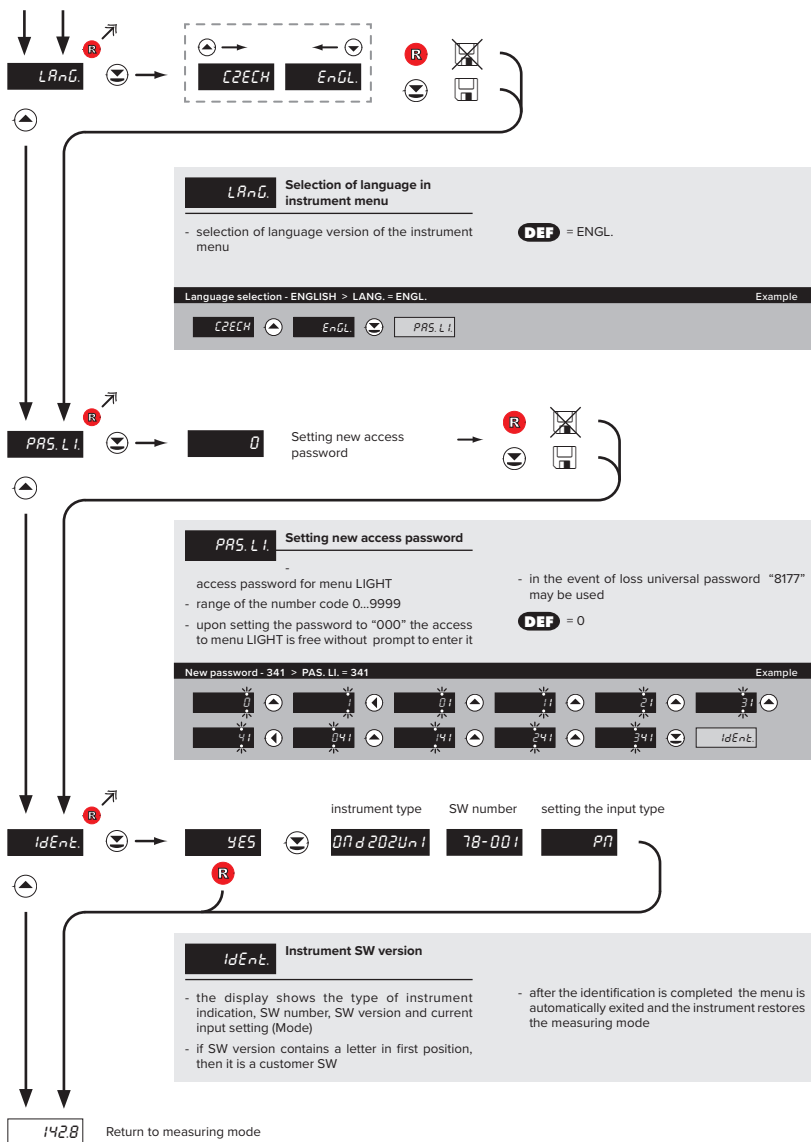

SETTING **PROFI**

For expert users

Complete instrument menu

Access is password protected

Possibility to arrange items of the **USER MENU**

Tree menu structure

6.0 SETTING "PROFI"

PROFI

Complete programming menu

- contains complete instrument menu and is protected by optional number code
- designed for expert users
- preset from manufacture is menu **LIGHT**

Switching over to "PROFI" menu

>3 s



- access to **PROFI** menu
- authorization for access to **PROFI** menu does not depend on setting under item **SERVIC. > MENU**
- password protected access (unless set as follows under the item **SERVIC. > N. PASS. > PROFI =0**)



- access to menu selected under item **SERVIC. > MENU > LIGHT/PROFI**
- password protected access (unless set as follows under the item **SERVIC. > N. PASS. > LIGHT =0**)
- for access to **LIGHT** menu passwords for **LIGHT** and **PROFI** menu may be used



6. SETTING PROFI

Programming sch

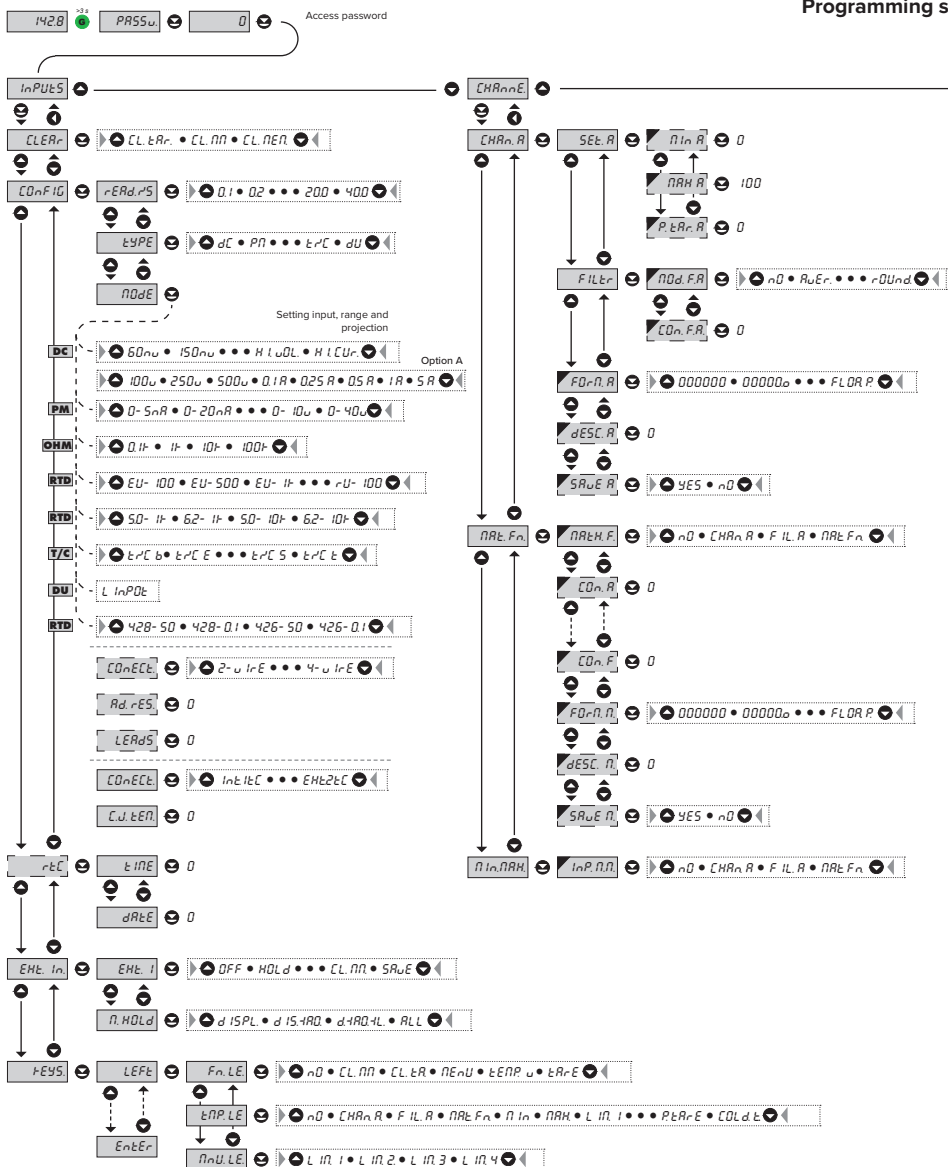



Menu PROFI MENU

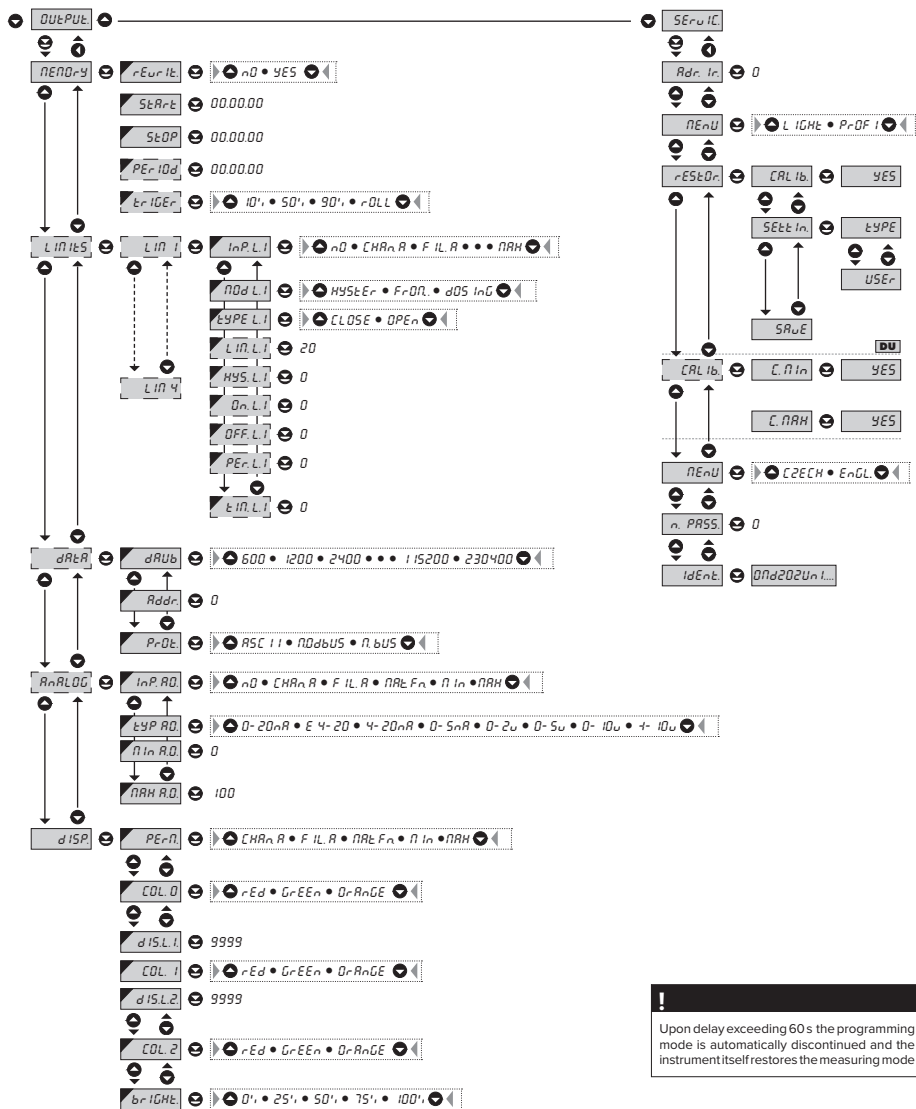

! Upon delay exceeding 60 s the programming mode is automatically discontinued and the instrument itself restores the measuring mode

6. SETTING PROFI

6.1 SETTING "PROFI" - INPUT

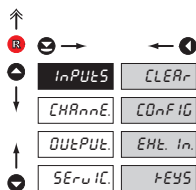

The primary instrument parameters are set in this menu

| | |
|---------|---|
| CLEAR | Resetting internal values |
| CONF IG | Selection of measuring range and parameters |
| EXT. In | Setting external inputs functions |
| FEYS | Assigning further functions to keys on the instrument |

6.1.1 RESETTING INTERNAL VALUES

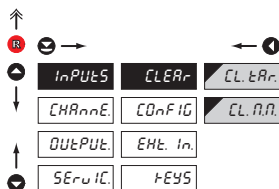

| | |
|----------|---------------------------|
| CLEAR | Resetting internal values |
| CL. tAR. | Tare resetting |
| CL. n.n. | Resetting min/max value |

- resetting memory for the storage of minimum and maximum value achieved during measurement

6.1.2a SELECTION OF MEASURING RATE

↑

Ⓡ →

← Ⓚ

| | | | |
|---------|----------|---------|------|
| INPUTS | CLEAR | rERd.rS | 40.0 |
| CHARnNE | CONFIG | TYPE | 20.0 |
| OUTPUL | EMt. In. | ADdE | 10.0 |
| SERuIC | FEYS | CONFECt | 5.0 |
| | | C.U.tEN | 2.0 |
| | | Ad.rES | 1.0 |
| | | LEAdS | 0.5 |
| | | | 0.2 |
| | | | 0.1 |

DEF

↑

Ⓚ

rERd.rS Selection of measuring rate

| | |
|------|---------------------|
| 40.0 | 40,0 measurements/s |
| 20.0 | 20,0 measurements/s |
| 10.0 | 10,0 measurements/s |
| 5.0 | 5,0 measurements/s |
| 2.0 | 2,0 measurements/s |
| 1.0 | 1,0 measurement/s |
| 0.5 | 0,5 measurements/s |
| 0.2 | 0,2 measurements/s |
| 0.1 | 0,1 measurements/s |

6.1.2b SELECTION OF „INSTRUMENT“ TYPE

↑

Ⓡ →

← Ⓚ

| | | | |
|---------|----------|---------|--------|
| INPUTS | CLEAR | rERd.rS | dC |
| CHARnNE | CONFIG | TYPE | Pn |
| OUTPUL | EMt. In. | ADdE | OHn |
| SERuIC | FEYS | CONFECt | rtd-Pt |
| | | C.U.tEN | rtd-ni |
| | | Ad.rES | tC |
| | | LEAdS | dU |
| | | | rtd-Cu |

DEF

↑

Ⓚ

TYPE Selection of „instrument“ type

- selection of particular type of "instrument" is bound to relevant dynamic items

| | |
|--------|-----------------------------------|
| dC | DC voltmeter |
| Pn | Process monitor |
| OHn | Ohmmeter |
| rtd-Pt | Thermometer for Pt xxx |
| rtd-ni | Thermometer for Ni xxx |
| tC | Thermometer for thermocouples |
| dU | Display for linear potentiometers |
| rtd-Cu | Thermometer for Cu xxx |

6. SETTING PROFI

6.1.2c SELECTION OF MEASURING RANGE

R M →
 ↑
 ↓

| | | | | | | | |
|----------|----------|------------|--------|------|-----|------|-----|
| INPUTS | CLEAR | REAR.S | DC | 60nV | OHM | 100r | DEF |
| CHARACT. | CONFIG. | TYPE | 150nV | 1t | | | |
| OUTPUT | EXT. In. | MODE | 300nV | 10t | | | |
| SERUI.C. | TEYS | CONFECT. | 1200nV | 100t | | | |
| | | [C.V. tEN] | | | | | |
| | | [Ad. rES] | | | | | |
| | | [LEAR.S] | | | | | |

| | | |
|-----|--------|---------|
| | DC - A | PM |
| | 100u | 0-5nA |
| | 250u | 0-20nA |
| DEF | 500u | 4-20nA |
| | 0.10A | 0-2u |
| | 0.25A | 0-5u |
| | 0.50A | 0-10u |
| | 1.00A | 0-40u |
| | 5.00A | Er:4-20 |

| | | |
|-----|--------|---------|
| | RTD-Pt | RTD-Cu |
| DEF | EU-100 | 428-50 |
| | EU-500 | 428-0.1 |
| | EU-110 | 426-50 |
| | US-100 | 426-0.1 |
| | rU-50 | |
| | rU-100 | |

| | | |
|-----|---------|-------|
| | RTD-Ni | T/C |
| DEF | 5.0-1t | t°C E |
| | 6.2-1t | t°C J |
| | 5.0-10t | t°C K |
| | 6.2-10t | t°C N |
| | | t°C R |
| | | t°C S |

| | | |
|-----|-----------|-------|
| | DU | |
| DEF | LIn.POLt. | t°C S |
| | | t°C t |

MODE Selection of instrument measuring range

| | Menu | Measuring range |
|--------|---------|---|
| DC | 60 mV | ±60 mV |
| | 150 mV | ±150 mV |
| | 300 mV | ±300 mV |
| | 1200mV | ±1.2 V |
| | | |
| DC - A | 100 V | ±100 V |
| | 250 V | ±250 V |
| | 500 V | ±500 V |
| | 0.10 A | ±0.1 A |
| | 0.25 A | ±0.25 A |
| | 0.50 A | ±0.5 A |
| | 1.00 A | ±1 A |
| | 5.00 A | ±5 A |
| | | |
| PM | Menu | Measuring range |
| | 0-5mA | 0...5 mA |
| | 0-20mA | 0...20 mA |
| | 4-20mA | 4...20 mA |
| | 0-2 V | ±2 V |
| | 0-5 V | ±5 V |
| | 0-10 V | ±10 V |
| 0-40 V | ±40 V | |
| | Er:4-20 | 4...20 mA, with error statement of „underflow“ upon signal smaller than 3.36 mA |
| OHM | Menu | Measuring range |
| | 100 R | 0...100 Ω |
| | 1k | 0...1 kΩ |
| | 10k | 0...10 kΩ |
| | 100k | 0...100 kΩ |
| RTD-Pt | Menu | Measuring range |
| | EU-100 | Pt 100 (3 850 ppm/°C) |
| | EU-500 | Pt 500 (3 850 ppm/°C) |
| | EU-1k0 | Pt 1000 (3 850 ppm/°C) |
| | US-100 | Pt 100 (3 920 ppm/°C) |
| | RU-500 | Pt 50 (3 910 ppm/°C) |
| | RU-100 | Pt 100 (3 910 ppm/°C) |
| RTD-Ni | Menu | Measuring range |
| | 5.0-1k | Ni 1 000 (5 000 ppm/°C) |
| | 6.2-1k | Ni 1 000 (6 180 ppm/°C) |
| | 5.0-10k | Ni 10 000 (5 000 ppm/°C) |
| | 6.2-10k | Ni 10 000 (6 180 ppm/°C) |
| RTD-Cu | Menu | Measuring range |
| | 428-50 | Cu 50 (4 280 ppm/°C) |
| | 428-0.1 | Cu 1 00 (4 280 ppm/°C) |
| | 426-50 | Cu 50 (4 260 ppm/°C) |
| | 426-0.1 | Cu 100 (4 260 ppm/°C) |
| T/C | Menu | Type of thermocouple |
| | T/C B | B |
| | T/C E | E |
| | T/C J | J |
| | T/C K | K |
| | T/C N | N |
| | T/C R | R |
| | T/C S | S |
| | T/C T | T |
| T/C L | L | |

6.1.2d SELECTION OF TYPE OF SENSOR CONNECTION
RTD OHM T/C

Navigation icons: ↑, ↓, ←, →, R, DEF

| | | | | |
|---------|----------|----------|--------|-----|
| INPUTS | CLERr | rERd.rS | 2-uIrE | DEF |
| CHARnE | COntIB. | tYPE | 3-uIrE | |
| OUtPUt. | EHt. In. | NOdE | 4-uIrE | |
| SErVIC. | FEYS | COntECT. | | |
| | | Ad.rES. | | |
| | | LEAdS | | |

Navigation icons: ↑, ↓, ←, →, R, DEF

| | | | | |
|---------|----------|----------|---------|-----|
| INPUTS | CLERr | rERd.rS | InE.tEt | DEF |
| CHARnE | COntIB. | tYPE | InE.2Et | |
| OUtPUt. | EHt. In. | NOdE | EHt.tEt | |
| SErVIC. | FEYS | COntECT. | EHt.2Et | |
| | | C.J.tEt. | | |

COntECT. Selection of type of sensor connection

RTD OHM

2-uIrE 2-wire connection

3-uIrE 3-wire connection

4-uIrE 4-wire connection

T/C

InE.tEt Measurement without reference thermocouple

- measuring cold junction at instrument brackets

InE.2Et Measurement with reference thermocouple

- measuring cold junction at instrument brackets with anti-series connected reference thermocouple

EHt.tEt Measurement without reference thermocouple

- the entire measuring set is working under invaried and constant temperature

EHt.2Et Measurement with reference thermocouple

- when using compensation box

!

Method and procedure of setting the cold junctions is described in separate chapter on page 80

!

For thermocouple type "B" the items CONECT. and C.J. TEM. are not available

6. SETTING PROFI

6.1.2e SETTING TEMPERATURE OF COLD JUNCTION

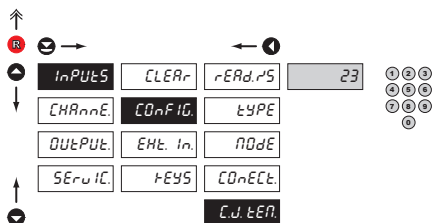
T/C

C.J. tEN. Setting temperature of cold junction

- range 0...99°C with compensation box

 - **DEF** = 23°C

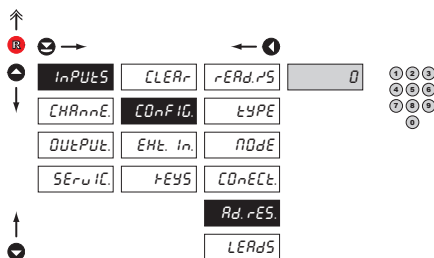
6.1.2f COMPENSATION OF 2-WIRE CONDUCT

RTD OHM

rAd.rES. Offset of the beginning of the measuring range

- in cases when it is necessary to offset the beginning of the range by certain value, e.g. while using sensor in measuring head

- entered directly in Ohm (0...9999)

 - **DEF** = 0

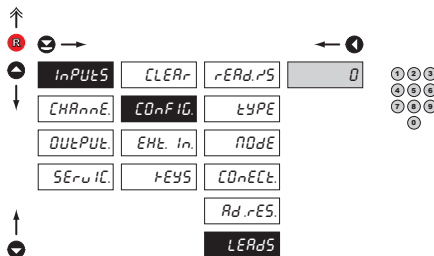
6.1.2g COMPENSATION OF 2-WIRE CONDUCT

RTD OHM

LEAdS Compensation of 2-wire conduct

- for measurement accuracy it is necessary to perform compensation of conduct always in case of 2-wire connection

- prior confirmation of the displayed prompt „YES“ it is necessary to substitute the sensor at the end of the conduct by a short-circuit

 - **DEF** = 0

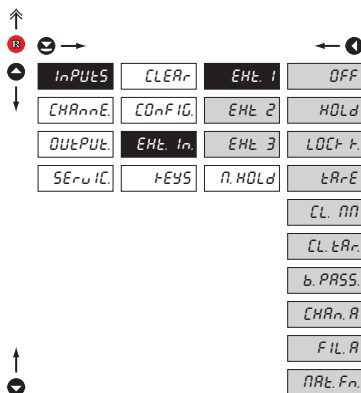
6.1.3a EXTERNAL INPUT FUNCTION SELECTION



| EXT. In | External input function selection |
|--|--|
| OFF | Input is off |
| HOLD | Activation of HOLD |
| LOCK K. | Locking keys on the instrument |
| TARE | Tare activation |
| CL. MIN | Resetting min/max value |
| CL. TARE | Tare resetting |
| b. PASS. | Activation of locking access into programming menu |
| LIGHT/PROFI | |
| CHANNEL A | Displaying value of "Channel A" |
| FIL. A | Displaying value of "Channel A" after being processed by digital filters |
| MATH. FN. | Displaying value of "Mathematical function" |
| - DEF | EXT. 1 > HOLD |
| - DEF | EXT. 2 > LOCK K. |
| - DEF | EXT. 3 > TARE |
| * | |
| Setting procedure is identical for EXT. 2 and EXT. 3 | |

6. SETTING PROFI

6.1.3b SELECTION OF FUNCTION "HOLD"

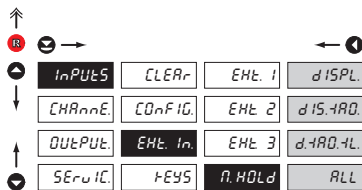

n.HOLD Selection of function "HOLD"

- d ISPL** "HOLD" locks only the value displayed
- d IS.ARD** "HOLD" locks the value displayed and on AO
- d.ARD.L** "HOLD" locks the value displayed, on AO and limit evaluation
- ALL** "HOLD" locks the entire instrument

6.1.4a OPTIONAL ACCESSORY FUNCTIONS OF THE KEYS

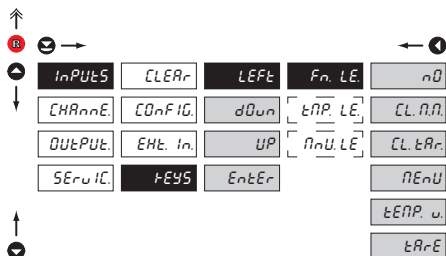

Fn.LE Assigning further functions to instrument keys

- „FN. LE.“ > executive functions
- „TMP. LE.“ > temporary projection of selected values
- „MNU. LE.“ > direct access into menu on selected item

- nD** Key has no further function
- CL.nD** Resetting min/max value
- CL.tAr** Tare resetting
- nEnU** Direct access into menu on selected item
- after confirmation of this selection the "MNU. LE." item is displayed on superior menu level, where required selection is performed
- tENP.u** Temporary projection of selected values
- after confirmation of this selection the item "TMP. LE." is displayed on superior menu level, where required selection is performed
- tArE** Tare function activation

| Preset values of the control keys DEF | |
|--|-----------------|
| LEFT | Show Tare |
| UP | Show Max. value |
| DOWN | Show Min. value |
| ENTER | w/o function |

!
Setting is identical for LEFT, DOWN, UP and ENTER

6.1.4b OPTIONAL ACCESSORY FUNCTIONS OF THE KEYS - TEMPORARY PROJECTION

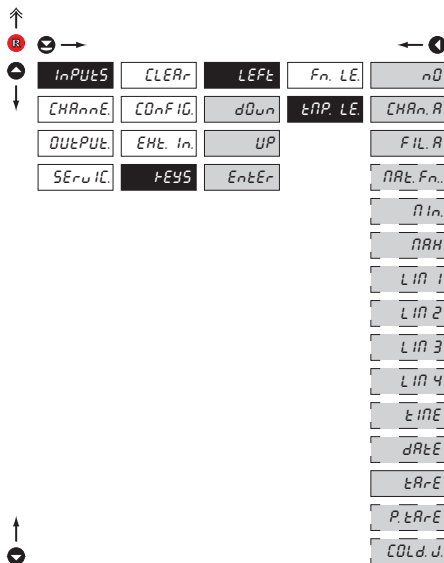
**tAP. LE** Temporary projection of selected item

- "Temporary" projection of selected value is displayed for the time of keystroke
- "Temporary" projection may be switched to permanent by pressing **RE** + "Selected key", this holds until the stroke of any key

| | |
|-----------|--|
| nD | Temporary projection is off |
| CHAn. A | Temporary projection of "Channel A" value |
| FIL. A | Temporary projection of "Channel A" value after processing digital filters |
| nAR. Fn. | Temporary projection of "Mathematic functions" value |
| nIn | Temporary projection of "Min. value" |
| nAH | Temporary projection of "Max. value" |
| LIn 1 | Temporary projection of "Limit 1" value |
| LIn 2 | Temporary projection of "Limit 2" value |
| LIn 3 | Temporary projection of "Limit 3" value |
| LIn 4 | Temporary projection of "Limit 4" value |
| tInE | Temporary projection of "TIME" value |
| dAtE | Temporary projection of "DATE" value |
| tAR. E | Temporary projection of "TARE" value |
| P. tAR. E | Temporary projection of "P. TARE" value |
| COld. J. | Temporary projection of "CJC" value |

!
Setting is identical for LEFT, DOWN, UP and ENTER

6. SETTING PROFI

6.1.5c

OPTIONAL ACCESSORY FUNCTIONS OF THE KEYS - DIRECT ACCESS TO ITEM

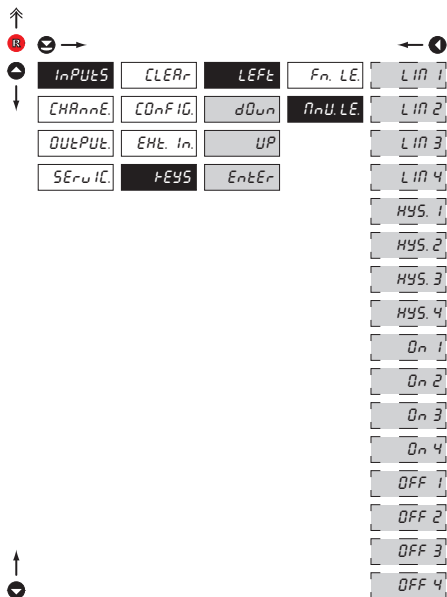

NONU, LE

Assigning access to selected menu item

LIM 1 Direct access to item "LIM 1"

LIM 2 Direct access to item "LIM 2"

LIM 3 Direct access to item "LIM 3"

LIM 4 Direct access to item "LIM 4"

HYS. 1 Direct access to item "HYS. 1"

HYS. 2 Direct access to item "HYS. 2"

HYS. 3 Direct access to item "HYS. 3"

HYS. 4 Direct access to item "HYS. 4"

ON 1 Direct access to item "ON 1"

ON 2 Direct access to item "ON 2"

ON 3 Direct access to item "ON 3"

ON 4 Direct access to item "ON 4"

OFF 1 Direct access to item "OFF 1"

OFF 2 Direct access to item "OFF 2"

OFF 3 Direct access to item "OFF 3"

OFF 4 Direct access to item "OFF 4"



Setting is identical for LEFT, DOWN, UP and ENTER



6. SETTING PROFI

6.2 SETTING "PROFI" - CHANNELS

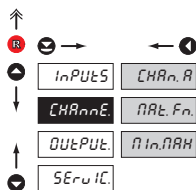

The primary instrument parameters are set in this menu

| | |
|----------|---|
| CHAn.A | Setting parameters of measuring "Channel" |
| nARt.Fn | Setting parameters of mathematic functions |
| nIn.nARH | Selection of access and evaluation of Min/max value |

6.2.1a DISPLAY PROJECTION

DC PM DU OHM

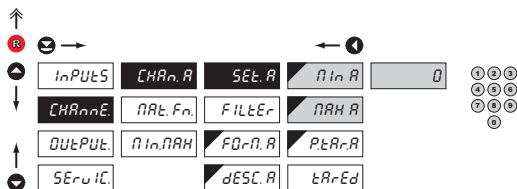

SEt.A Setting display projection

nIn.A Setting display projection for minimum value of input signal

- range of the setting is -99999...999999
- **DEF** = 0

nARH.A Setting display projection for maximum value of input signal

- range of the setting is -99999...999999
- **DEF** = 100

6.2.1b SETTING FIXED TARE

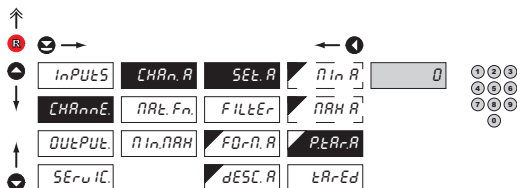

P.tAR.R Setting "Fixed tare" value

- setting is designed for the event when it is necessary to firmly shift the beginning of the range by known size
- when setting (P. TAR. A ≠ 0) is in effect, display does not show the "T" symbol
- range of the setting is: -99999...999999

- **DEF** = 0

6.2.1b SETTING FIXED TARE



tAr.Ed Selection of the position of tare

CHAr.n.R The value will be tared before linearisation and digital filter

FIl.R The value will be tared after linearisation and digital filter

6.2.1c DIGITAL FILTERS

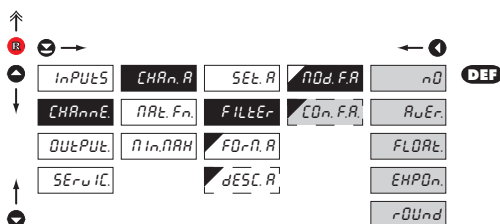

nOd.F.A Selection of digital filters

- at times it is useful for better user projection of data on display to modify it mathematically and properly, where the following filters may be used:

nD Filters are off

RuEr Measured data average

- arithmetic average from given number („CON.F.A.“) of measured values
- range 2...100

FLARt Selection of floating filter

- floating arithmetic average from given number („CON.F.A.“) of measured data and updates with each measured value
- range 2...30

EHPDn Selection of exponential filter

- integration filter of first prvniho grade with time constant („CON.F.A.“) measurement
- range 2...100

rOUnd Measured value rounding

- is entered by any number, which determines the projection step (e.g. „CON.F.A.“=2,5 > display 0, 2,5, 5,...)

CO.n.F.A Setting constants

- this menu item is always displayed after selection of particular type of filter

DEF = 2

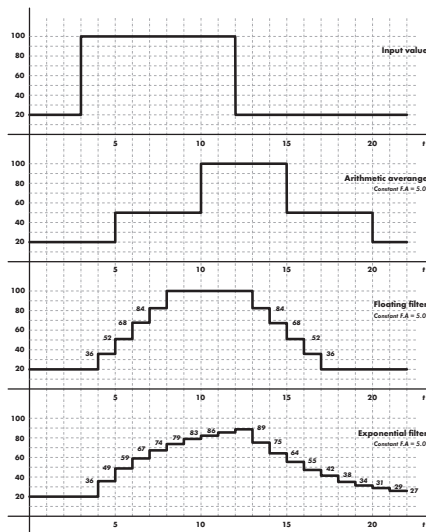

6. SETTING PROFI

6.2.1d PROJECTION FORMAT - POSITIONING OF DECIMAL POINT

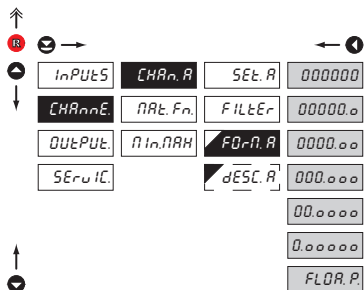

FDR.A Selection of decimal point

the instrument allows for classic projection of a number with positioning of the DP as well as projection with floating DP, allowing to display a number in its most exact form „FLOA.P.“

000000 Setting DP - XXXXXX.

00000.0 Setting DP - XXXXX.x

- **DEF** > **RTD** **T/C**

0000.00 Setting DP - XXXX.xx

- **DEF** > **DC** **PM** **DU** **OHM**

000.000 Setting DP - XXX.xxx

00.0000 Setting DP - XX.xxxx

0.00000 Setting DP - X.xxxxx

FLOA.P. Floating DP

6.2.1e PROJECTION OF DESCRIPTION - THE MEASURING UNITS

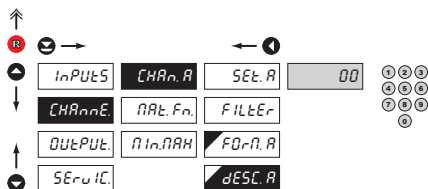

dESC.A Setting projection of descrpt. for "Channel A"

- projection of measured data may be extended (at the expense of the number of displayed places) by two characters for description
- description is set by shifted ASCII code, when two first places show the set description and two last characters their code in period 0...95
- description is cancelled by code 00

- **RTD** **T/C** **DEF** = °C

- **DC** **PM** **DU** **OHM** **DEF** =none

!

Table of signs on page 83



6.2.2a

MATHEMATIC FUNCTIONS

| | | | | |
|---------|---------|----------------|--------|------------|
| INPUTS | CHARA.R | MATH.F. | OFF | DEF |
| CHARACT | MATH.Fn | CON.B | POL In | |
| OUTPUT | ANAL.H | CON.b | IPNUL | |
| SERVIC. | | CON.E | LOGAr | |
| | | CON.d | EHPOn | |
| | | CON.E | POUEr | |
| | | CON.F | rOOb | |
| | | FOR.N.N | S In H | |
| | | dESC.N | | |

| | |
|---|--|
| MATH.F. | Selection of mathematic functions |
| OFF | Mathematic functions are off |
| <input type="checkbox"/> POL In | Polynome |
| $Ax^5 \square Bx^4 \square Cx^3 \square Dx^2 \square Ex \square F$ | |
| <input type="checkbox"/> IPNUL | 1/x |
| $\frac{A}{x^5} \square \frac{B}{x^4} \square \frac{C}{x^3} \square \frac{D}{x^2} \square \frac{E}{x} \square F$ | |
| <input type="checkbox"/> LOGAr | Logarithm |
| $A \square \ln \square \frac{Bx \square C}{Dx \square E} \square F$ | |
| <input type="checkbox"/> EHPOn | Exponential |
| $A \square e^{\frac{Bx \square C}{Dx \square E}} \square F$ | |
| <input type="checkbox"/> POUEr | Power |
| $A \square [Bx \square C]^{Dx \square E} \square F$ | |
| <input type="checkbox"/> rOOb | Root |
| $A \square \sqrt{\frac{Bx \square C}{Dx \square E}} \square F$ | |
| <input type="checkbox"/> S In H | Sin x |
| $A \sin^5 x \square B \sin^4 x \square C \sin^3 x \square D \sin^2 x$ $\square E \sin x \square F$ | |
| <input type="checkbox"/> CON.- | Setting constants for calculation of mat.functions |
| - this menu is displayed only after selection of given mathematic function | |

6. SETTING PROFI

6.2.2b MATHEMATIC FUNCTIONS - DECIMAL POINT

↑

⊖ →

← ⊕

↑

↓

↑

↓

| | | | |
|--------|----------|-----------|-----------------------|
| InPUtS | CHAn. R | ARtH. F | 000000 |
| CHAnnE | ARt. Fn | CO.n. R | 00000.0 |
| DUtPUt | n In.nRH | CO.n. b | 0000.00 |
| SERuIC | | CO.n. c | 000.000 |
| | | CO.n. d | 00.0000 |
| | | CO.n. E | 0.00000 |
| | | CO.n. F | FLOr.N. P. DEF |
| | | FOr.N. n. | |
| | | dESC. n. | |

FOr.N. n. Selection of decimal point

- the instrument allows for classic projection of a number with positioning of the DP as well as projection with floating DP, allowing to display a number in its most exact form „FLOA. P.“

| | |
|------------|----------------------|
| 000000 | Setting DP - XXXXXX. |
| 00000.0 | Setting DP - XXXXX.x |
| 0000.00 | Setting DP - XXXX.xx |
| 000.000 | Setting DP - XXX.xxx |
| 00.0000 | Setting DP - XX.xxxx |
| 0.00000 | Setting DP - X.xxxxx |
| FLOr.N. P. | Floating DP |

6.2.2c MATHEMATIC FUNCTIONS - MEASURING UNITS

↑

⊖ →

← ⊕

↑

↓

↑

↓

↑

↓

| | | | |
|--------|----------|-----------|----|
| InPUtS | CHAn. R | ARtH. F | 00 |
| CHAnnE | ARt. Fn | CO.n. R | |
| DUtPUt | n In.nRH | CO.n. b | |
| SERuIC | | CO.n. c | |
| | | CO.n. d | |
| | | CO.n. E | |
| | | CO.n. F | |
| | | FOr.N. n. | |
| | | dESC. n. | |

1 2 3
4 5 6
7 8 9
0

dESC. n. Setting projection of description for "MAT.FN"

- projection of measured data may be extended (at the expense of the number of displayed places) by two characters for description
- description is set by shifted ASCII code, when two first places show the set description and two last characters their code in period 0...95
- description is cancelled by code 00
- **DEF** = no description



Table of signs on page 83



6.2.3 SELECTION OF EVALUATION OF MIN/MAX VALUE

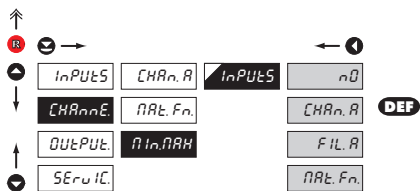

INPUTS Selection of evaluation of min/max value

- selection of value from which the min/max value will be calculated

- nD Evaluation of min/max value is off
- CHANNEL From "Channel A"
- FILTR From "Channel A" after digital filters processing
- MATH From "Mathematic functions"

6. SETTING PROFI

6.3 SETTING „PROFI“ - OUTPUTS

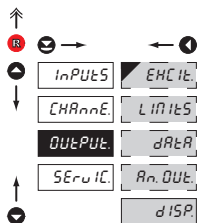

In this menu it is possible to set parameters of the instrument output signals

| | |
|-----------------|--|
| EHC It. | Volba výstupního napětí pomocného zdroje |
| LIMItS | Setting type and parameters of limits |
| dARtR | Setting type and parameters of data output |
| An. OUt. | Setting type and parameters of analog output |
| dISP. | Setting display projection and brightness |

6.3.1 SELECTION OF SENSOR EXCITATION VOLTAGE

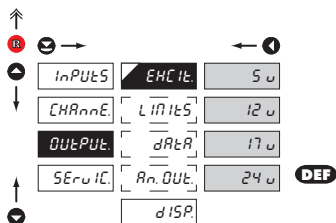

EHC It. Selection of sensor excitation voltage (aux. power supply)

| | |
|-------------|--------------------|
| 5 V | 5 VDC, max. 2.5 W |
| 12 V | 12 VDC, max. 2.5 W |
| 17 V | 17 VDC, max. 2.5 W |
| 24 V | 24 VDC, max. 2.5 W |

6.3.2a SELECTION OF INPUT FOR LIMITS EVALUATION

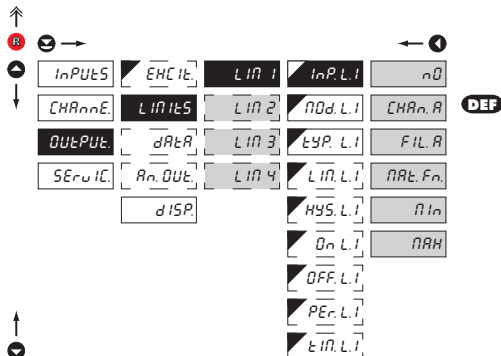

LIM 1 Selection evaluation of limits

- selection of value from which the limit will be evaluated

| | |
|----------------|--|
| n0 | Limit evaluation is off |
| CHAnnA | Limit evaluation from "Channel A" |
| FILA | Limit evaluation from "Channel A" after digital filters processing |
| NARt.Fn | Limit evaluation from "Mathematic functions" |
| nIn | Limit evaluation from "Min. value" |
| NARH | Limit evaluation from "Max. value" |

Setting is identical for LIM 2, LIM 3 and LIM 4

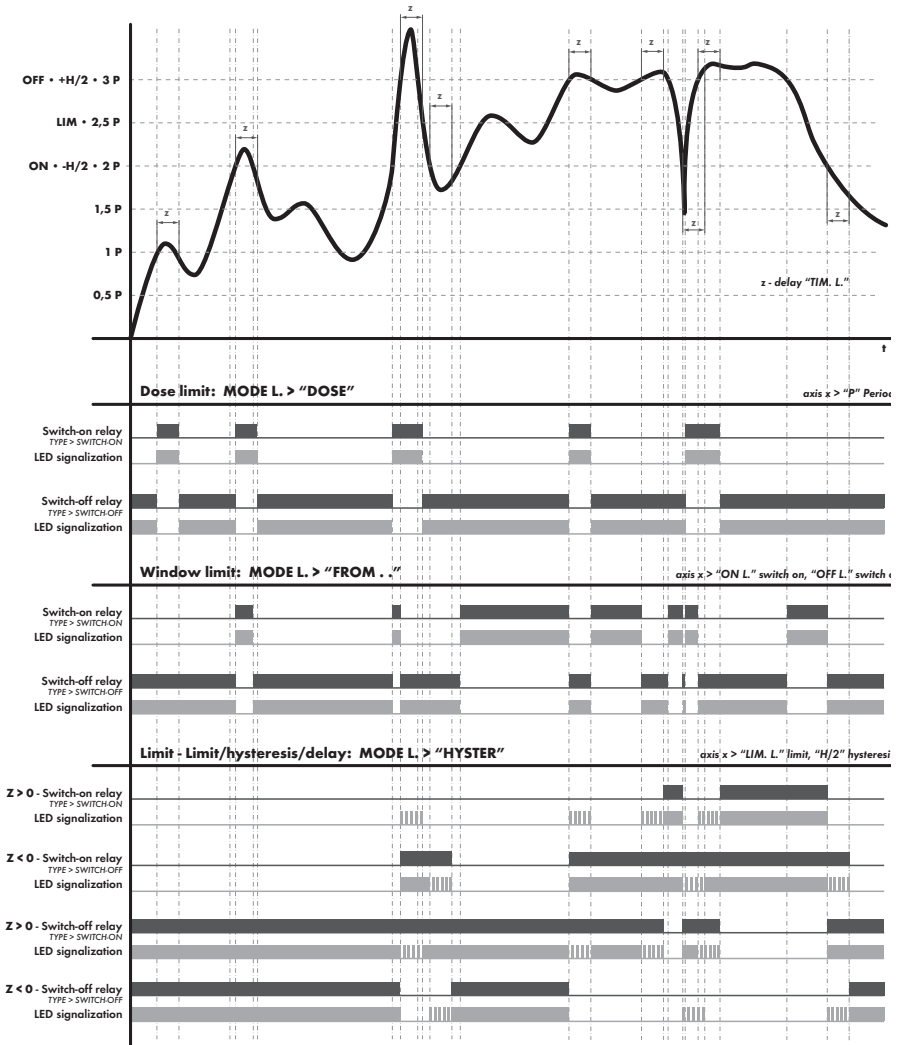

6. SETTING PROFI

6.3.2b SELECTION OF TYPE OF LIMIT

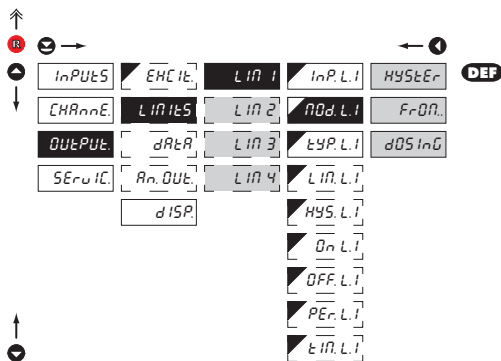

NOd.L.i Selection the type of limit

HYS.tER

Limit is in mode "Limit, hysteresis, delay"

- for this mode the parameters of "LIM. L." are set, at which the limit will shall react, "HYS. L." the hysteresis range around the limit (LIM $\pm 1/2$ HYS) and time "TIM. L." determining the delay of relay switch-on

FrON.

Frame limit

- for this mode the parameters are set for interval "ON. L." the relay switch-on and "OFF. L." the relay switch-off

dOSInG

Dose limit (periodic)

- for this mode the parameters are set for "PER. L." determining the limit value as well as its multiples at which the output is active and "TIM. L." indicating the time during which is the output active

Setting is identical for LIM 2, LIM 3 and LIM 4

6.3.2c SELECTION OF TYPE OF OUTPUT

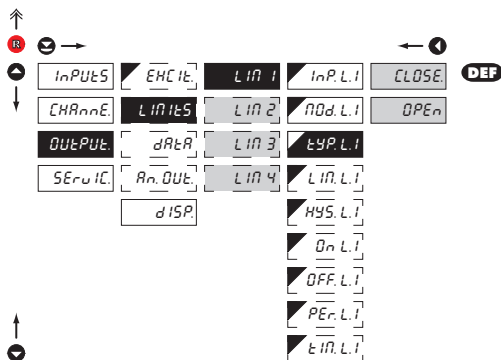

tYP.L.i Selection of type of output

CLOSE

Output switches on when condition is met

OPEn

Output switches off when condition is met

Setting is identical for LIM 2, LIM 3 and LIM 4



6.3.2d SETTING VALUES FOR LIMITS EVALUATION

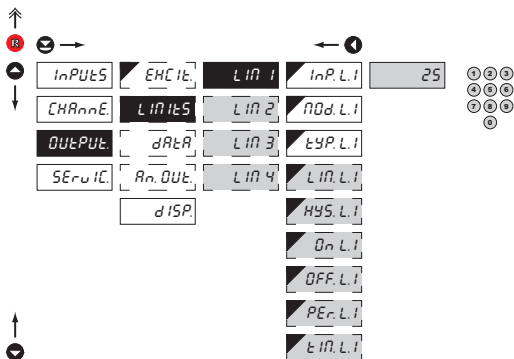

- LIM. L.1** Setting limit for switch-on
 - for type "HYSTER."
 - HYS. L.1** Setting hysteresis
 - for type "HYSTER."
 - indicates the range around the limit (in both directions, LIM. ±1/2 HYS.)
 - ON L.1** Setting the outset of the interval of limit switch-on
 - for type "FROM."
 - OFF L.1** Setting the end of the interval of limit switch-on
 - for type "FROM."
 - PER. L.1** Setting the period of limit switch-on
 - for type "DOSING"
 - TIM. L.1** Setting the time switch-on of the limit
 - for type "HYSTER." and "DOSING"
 - setting within the range: ±99,9 s
 - positive time > relay switches on after crossing the limit (LIM. L.1) and the set time (TIM. L.1)
 - negative time > relay switches off after crossing the limit (LIM. L.1) and the set negative time (TIM. L.1)
- !**
Setting is identical for LIM 2, LIM 3 and LIM 4

6. SETTING PROFI

6.3.3a SELECTION OF DATA OUTPUT BAUD RATE

| bAUD | Selection of data output baud rate |
|--------|------------------------------------|
| 600 | Rate - 600 Baud |
| 1200 | Rate - 1 200 Baud |
| 2400 | Rate - 2 400 Baud |
| 4800 | Rate - 4 800 Baud |
| 9600 | Rate - 9 600 Baud |
| 19200 | Rate - 19 200 Baud |
| 38400 | Rate - 38 400 Baud |
| 57600 | Rate - 57 600 Baud |
| 115200 | Rate - 115 200 Baud |
| 230400 | Rate - 230 400 Baud |

6.3.3b SETTING INSTRUMENT ADDRESS

| Addr. | Setting instrument address |
|--------------|---------------------------------------|
| - | setting in range 0...31 |
| - DEF | = 00 |
| Addr. | Setting instrument address - MODBUS |
| - | setting in range 1...247 |
| - DEF | = 1 |
| Adr. P.b. | Setting instrument address - PROFIBUS |
| - | setting in range 1...127 |
| - DEF | = 19 |



6.3.3c SELECTION OF DATA OUTPUT PROTOCOL

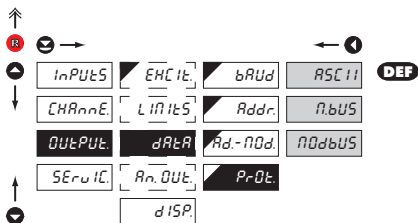

PrOt. Selection of the type of analog output

RSC11 Data protocol ASCII

n.bUS Data protocol DIN MessBus

MODbUS Data protocol MODBUS-RTU

- option is available only for RS 485

6.3.4a SELECTION OF INPUT FOR ANALOG OUTPUT

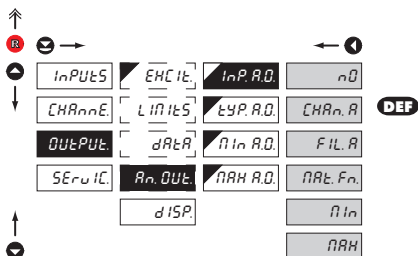

InP.A.O. Selection evaluation analog output

- selection of value from which the analog output will be evaluated

nO AO evaluation is off

CHAR.A AO evaluation from "Channel A"

FIL.A AO evaluation from "Channel A" after digital filters processing

ARt.F.n. AO evaluation from "Math.functions"

nIn AO evaluation from "Min.value"

ARt AO evaluation from "Max.value"

6. SETTING PROFI

6.3.4b SELECTION OF THE TYPE OF ANALOG OUTPUT

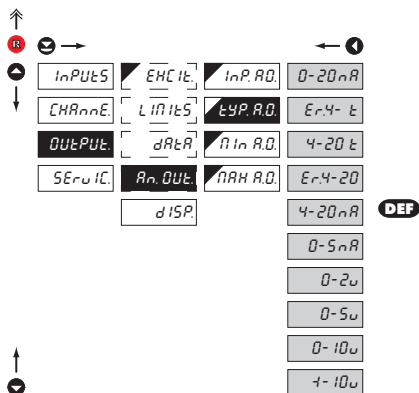

tYP. AO. Selection of the type of analog output

- 0-20mA** Type: 0...20 mA
- Er4-t** Type: 4...20 mA, with broken loop detection and indication of error statement (< 3,0 mA)
- 4-20t** Type: 4...20 mA, with broken loop detection (< 3,0 mA)
- Er4-20** Type: 4...20 mA, with indic. of error statement (< 3,0 mA)
- 4-20mA** Type: 4...20 mA
- 0-5mA** Type: 0...5 mA
- 0-2v** Type: 0...2 V
- 0-5v** Type: 0...5 V
- 0-10v** Type: 0...10 V
- ±10v** Type: ±10 V

6.3.4c SETTING THE ANALOG OUTPUT RANGE

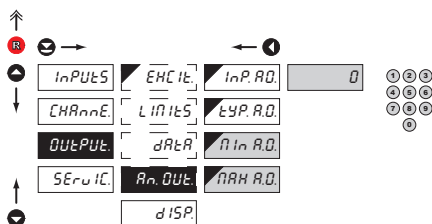

An. DUt. Setting the analog output range

- analog output is isolated and its value corresponds with displayed data. It is fully programmable, i.e. it allows to assign the AO limit points to two arbitrary points of the entire measuring range

nIn. AO. Assigning the display value to the beginning of the AO range

- range of the setting is -99999...999999

- **DEF** = 0

nRH. AO. Assigning the display value to the end of the AO range

- range of the setting is -99999...999999

- **DEF** = 100

6.3.5a SELECTION OF INPUT FOR DISPLAY PROJECTION

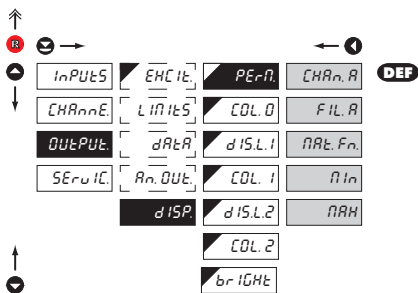
**PERF.** Selection display projection

selection of value which will be shown on the instrument display

| | |
|---------|--|
| CHAn.A | Projection of values from "Channel A" |
| FIL.R | Projection of values from "Channel A" after digital filters processing |
| MAt.Fn. | Projection of values from "Math.functions" |
| Min. | Projection of values from "Min.value" |
| MAx. | Projection of values from "Max.value" |

6.3.5b SELECTION OF DISPLAY COLOR

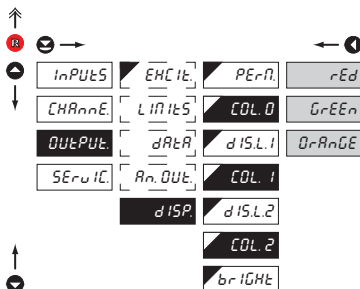
**COL.-** Selection of display color

- the color selection is governed by setting under items "DIS. L1" and "DIS. L2"

| | |
|--------|--------------|
| rEd | Red color |
| GrEEEn | Green color |
| OrAnGE | Orange color |

- "COL. 0." **DEF** = Green
- "COL. 1." **DEF** = Orange
- "COL. 2." **DEF** = Red

!
If the instrument is in the Hi Brightness LEDs execution, this menu item is not accessible

6. SETTING PROFI

6.3.5c SELECTION OF DISPLAY COLOR CHANGE

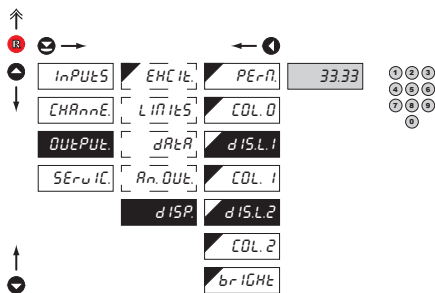

d15L.- Selection of display color change

- under items "DIS. L.1" and "DIS. L.2" the limit is set for the time when the display color shall change

- "DIS. L.1" **DEF** = 9999

- "DIS. L.2" **DEF** = 9999



If the instrument is in the Hi Brightness LEDs execution, this menu item is not accessible

6.3.5d SELECTION OF DISPLAY BRIGHTNESS

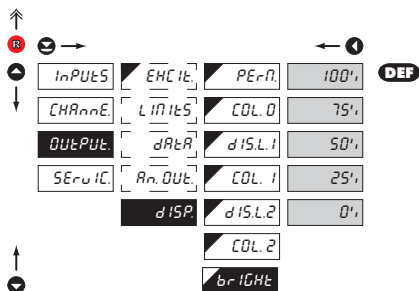

br1GHt Selection of display brightness

- by selecting display brightness we may appropriately react to light conditions in place of instrument location

0' Display is off

- after keystroke display turns on for 10 s

25' Display brightness - 25 %

50' Display brightness - 50 %

75' Display brightness - 75 %

100' Display brightness - 100 %



6. SETTING PROFI

6.4 SETTING "PROFI" - SERVICE

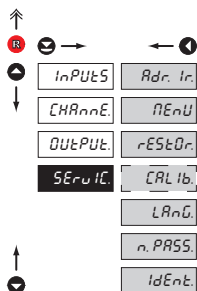

The instrument service functions are set in this menu

| | |
|-----------------|--|
| Adr. Ir. | Nastavení adresy IR ovládání |
| nEnU | Selection of menu type |
| LIGHT/PROFI | |
| rEStOr. | Restore instrument manufacture setting and calibration |
| CARL Ib | Input range calibration for „DU“ version |
| LAnG. | Language version of instrument menu |
| n.PASS. | Setting new access password |
| IdEnt. | Instrument identification |

6.4.1 SETTING THE ADDRESS OF IR REMOTE CONTROL

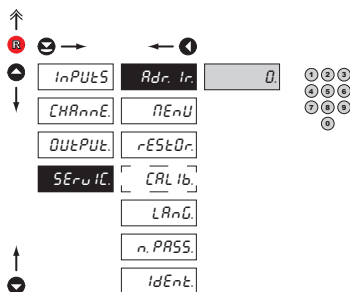

Adr. Ir. Setting the address of IR remote control

- setting the remote control address is inevitable only in case there are other large displays OMD 202 within the reach of IR remote control
- range of the setting is 0..99

- **DEF** = 0

6.4.2 SELECTION OF TYPE OF PROGRAMMING MENU

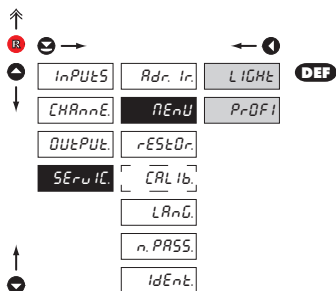
**PROF** Selection of menu type - LIGHT/PROFI

- enables setting the menu complexity according to user needs and skills

LIGHT Active LIGHT menu

- simple programming menu, contains only items necessary for configuration and instrument setting
- linear menu > items one after another

PROFI Active PROF menu

- complete programming menu for expert users
- tree menu



Change of setting is valid upon next access into menu

6. SETTING PROFI

6.4.3 RESTORATION OF MANUFACTURE SETTING

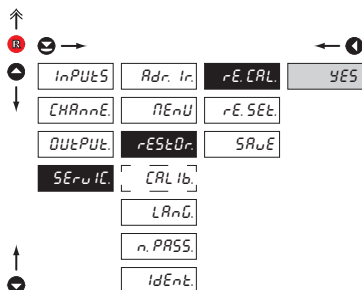

rESTOR Restoration of manufacture setting

- in the event of error setting or calibration, manufacture setting may be restored

rE.CAL Restoration of manufacture calibration of the instrument

- prior executing the changes you will be asked to confirm you selection „YES“

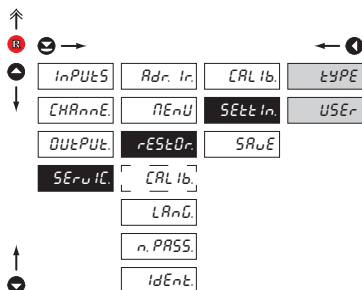

rE.SEt Restoration of instrument manufacture setting

- generating the manufacture setting for currently selected type of instrument (items marked DEF)

USER Restoration of instrument user setting

- generating the instrument user setting, i.e. setting stored under SERVIC./RESTOR./SAVE

SAUE Save instrument user setting

- storing the user setting allows the operator to restore it in future if needed



After restoration the instrument switches off for couple seconds

| JOBS PERFORMED | RESTORE | |
|---|-------------|---------|
| | CALIBRATION | SETTING |
| cancel USER menu rights | ✓ | ✓ |
| deletes table of items order in USER - LIGHT menu | ✓ | ✓ |
| adds items from manufacture to LIGHT menu | ✓ | ✓ |
| deletes data stored in FLASH | ✓ | ✓ |
| cancel or linearization tables | ✓ | ✓ |
| clears tare | ✓ | ✓ |
| restore manufacture calibration | ✓ | ✗ |
| restore manufacture setting | ✗ | ✓ |

6.4.4 CALIBRATION - INPUT RANGE

DU

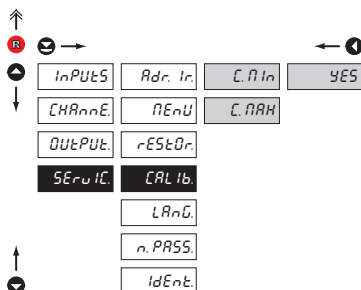

CAL Ib. Input range calibration

- when "C. MIN" is displayed, move the potentiometer traveller to the required minimum position and confirm by „Enter“, calibration is confirmed by "YES"
- when "C. MAX" is displayed, move the potentiometer traveller to required maximum position and confirm by „Enter“, calibration is confirmed by „YES“

6.4.5 SELECTION OF INSTRUMENT MENU LANGUAGE VERSION

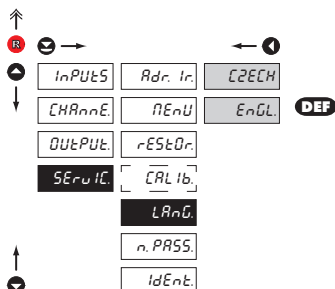

LANG. Selection of instrument menu language version

- CZECH Instrument menu is in Czech
- ENGL. Instrument menu is in English

6. SETTING PROFI

6.4.6 SETTING NEW ACCESS PASSWORD

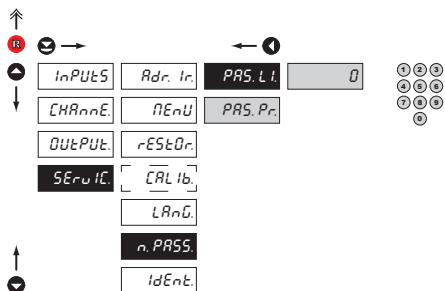

n.PASS Setting new password for access to LIGHT and PROFI menu

- this option allows to change the numeric code, which blocks the access into LIGHT and PROFI Menu.
- numerici code range: 0...9999
- universal passwords in the event of loss: LIGHT Menu > „8177“ PROFI Menu > „7915“

6.4.7 INSTRUMENT IDENTIFICATION

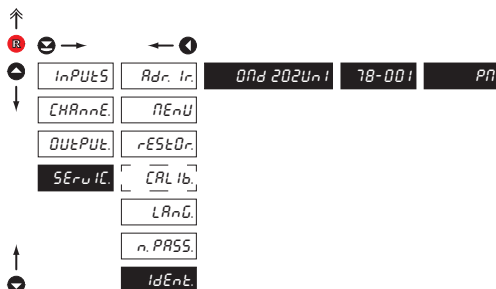

IdEnt. Projection of instrument SW version

- display shows type identification of the instrument, SW number, SW version and current input setting (Mode)
- if the SW version reads a letter on first position, it is a customer SW

| IDENT. | Blok | Description |
|--------|-------------------|-------------|
| 1. | Instrument | |
| 2. | no. of SW version | |
| 3. | type/input mode | |



SETTING USER

For user operation

Menu items are set by the user (Profi/Light) as per request

Access is not password protected

Optional menu structure either tree (PROFI) or linear (LIGHT)

7.0 SETTING ITEMS INTO "USER" MENU

- **USER** menu is designed for users who need to change only several items of the setting without the option to change the primary instrument setting (e.g. repeated change of limit setting)
- there are no items from manufacture permitted in **USER** menu
- on items indicated by inverse triangle  L I
- setting may be performed in **LIGHT** or **PROFI** menu, with the **USER** menu then overtaking the given menu structure

Setting

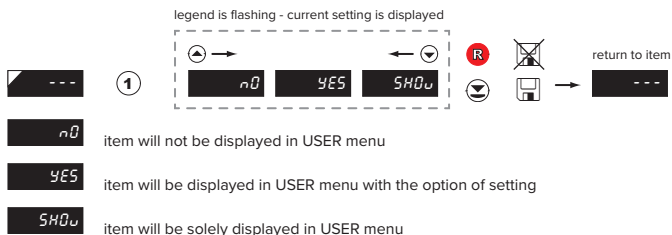

Setting items into „USER“ menu

When setting up the USER menu out of active LIGHT menu it is possible to rank the menu items (max. 10) in the order we want them to appear in the menu.

Setting up the ranking order



Example of setting up menu items into "USER" menu

As an example we are going to use a direct access into menu items Limit1 and Limit2 (the given example is for Light menu but can be applied also in Profi menu).

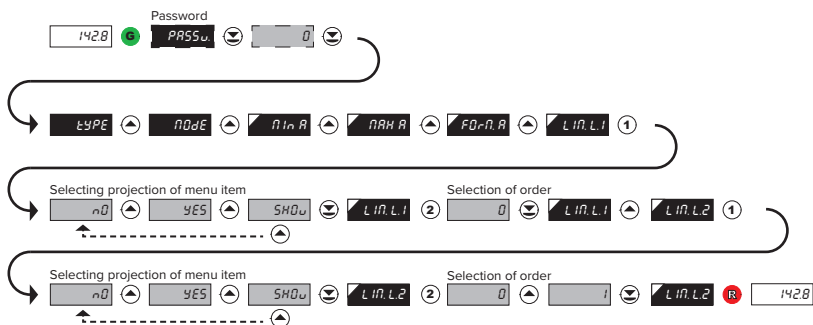

The resulting setting is as follows: After pressing button **R**, „LIM L.1“ is projected. By pressing **☺** you confirm this and you set the desired limit value, alternatively by pressing button **☺** you can go over to setting of „LIM. L.2“ where you repeat the procedure. You can finish the setting up by pressing the **☺** button, by which you save the latest setting and by pressing the **R** you return to the operating mode.

8. METHOD OF MEASURING THE CJC

Instrument with input for temperature measurement with thermocouple allows to set two types of measurement of cold junction.

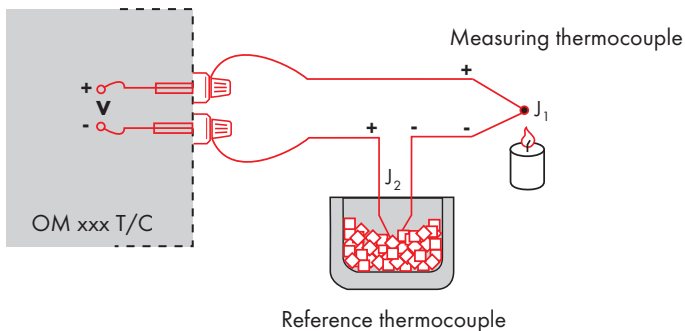

WITH REFERENCE THERMOCOUPLE

- a reference thermocouple may be located in the same place as the measuring instrument or in place with stable temperature/compensation box
- when measuring with reference thermocouple set $\text{C}0nE\text{C}\text{C}$ in the instrument menu to $in\text{E}2\text{E}\text{C}$ or $E\text{H}\text{E}2\text{E}\text{C}$
- when using a thermostat (a compensation box or environment with constant temperature) set in the instrument menu $\text{C}J\text{C}\text{E}\text{E}\text{N}$, its temperature (applies for setting $\text{C}0nE\text{C}\text{C}$ to $E\text{H}\text{E}2\text{E}\text{C}$)
- if the reference thermocouple is located in the same environment as the measuring instrument then set in the instrument menu $\text{C}0nE\text{C}\text{C}$ to $in\text{E}2\text{E}\text{C}$. Based on this selection the measurement of the ambient temperature is performed by a sensor located in the instrument terminal board.

WITHOUT REFERENCE THERMOCOUPLE

- inaccuracy originating from the creation of dissimilar thermocouples on the transition point terminal/conductor of the thermocouple is not compensated for in the instrument
- when measuring without reference thermocouple set $\text{C}0nE\text{C}\text{C}$ in the instrument menu to $in\text{E}1\text{E}\text{C}$ or $E\text{H}\text{E}1\text{E}\text{C}$
- when measuring temperature without reference thermocouple the error in measured data may be as much as 10°C (applies for setting $\text{C}0nE\text{C}\text{C}$ to $E\text{H}\text{E}1\text{E}\text{C}$)



The instruments communicate via serial line RS232 or RS485. For communication they use the ASCII protocol. Communication runs in the following format:

- ASCII: 8 bit, no parity, one stop bit
- DIN MessBus: 7 bit, even parity, one stop bit

The transfer rate is adjustable in the instrument menu. The instrument address is set in the instrument menu in the range of 0 ÷ 31. The manufacture setting always presets the ASCII protocol, rate of 9600 Baud, address 00. The type of line used - RS232 / RS485 - is determined by an output board automatically identified by the instrument.

The commands are described in specifications you can find at [na www.orbit.merret.cz/rs](http://na.www.orbit.merret.cz/rs) or in the OM Link program.

DETAILED DESCRIPTION OF COMMUNICATION VIA SERIAL LINE

| EVENT | TYPE | PROTOCOL | TRANSMITTED DATA | | | | | | | | | | | | | | | | | | | |
|--|---------------------------|----------|--------------------------------------|--------------------------------------|-----|------|------|------|------|-----|-----|-----|-----|-----|-----|-----|-----|-----|-----|-------|-------|-------|
| Data solicitation (PC) | 232 | ASCII | # | A | A | <CR> | | | | | | | | | | | | | | | | |
| | | MessBus | No - data is transmitted permanently | | | | | | | | | | | | | | | | | | | |
| | 485 | ASCII | # | A | A | <CR> | | | | | | | | | | | | | | | | |
| | | MessBus | <SADR> | <ENQ> | | | | | | | | | | | | | | | | | | |
| Data transmission (instrument) | 232 | ASCII | > | D | (D) | (D) | (D) | (D) | (D) | (D) | (D) | (D) | (D) | (D) | (D) | (D) | (D) | (D) | (D) | <CR> | | |
| | | MessBus | <STX> | D | (D) | (D) | (D) | (D) | (D) | (D) | (D) | (D) | (D) | (D) | (D) | (D) | (D) | (D) | (D) | (D) | <ETX> | <BCC> |
| | 485 | ASCII | > | D | (D) | (D) | (D) | (D) | (D) | (D) | (D) | (D) | (D) | (D) | (D) | (D) | (D) | (D) | (D) | (D) | <CR> | |
| | | MessBus | <STX> | D | (D) | (D) | (D) | (D) | (D) | (D) | (D) | (D) | (D) | (D) | (D) | (D) | (D) | (D) | (D) | (D) | <ETX> | <BCC> |
| Confirmation of data acceptance (PC) OK | 485 | MessBus | <DLE> | 1 | | | | | | | | | | | | | | | | | | |
| Confirmation of data acceptance (PC) Bad | | | <NAK> | | | | | | | | | | | | | | | | | | | |
| Sending address (PC) prior command | | | <EADR> | <ENQ> | | | | | | | | | | | | | | | | | | |
| Confirmation of address (instrument) | | | <SADR> | <ENQ> | | | | | | | | | | | | | | | | | | |
| Command transmission (PC) | 232 | ASCII | # | A | A | N | P | (D) | (D) | (D) | (D) | (D) | (D) | (D) | (D) | (D) | (D) | (D) | (D) | <CR> | | |
| | | MessBus | <STX> | \$ | N | P | (D) | (D) | (D) | (D) | (D) | (D) | (D) | (D) | (D) | (D) | (D) | (D) | (D) | <ETX> | <BCC> | |
| | 485 | ASCII | # | A | A | N | P | (D) | (D) | (D) | (D) | (D) | (D) | (D) | (D) | (D) | (D) | (D) | (D) | <CR> | | |
| | | MessBus | <STX> | \$ | N | P | (D) | (D) | (D) | (D) | (D) | (D) | (D) | (D) | (D) | (D) | (D) | (D) | (D) | <ETX> | <BCC> | |
| Command confirmation (instrument) | 232 | ASCII | OK | ! | A | A | <CR> | | | | | | | | | | | | | | | |
| | | | Bad | ? | A | A | <CR> | | | | | | | | | | | | | | | |
| | | Messbus | | No - data is transmitted permanently | | | | | | | | | | | | | | | | | | |
| | | 485 | ASCII | OK | ! | A | A | <CR> | | | | | | | | | | | | | | |
| | Bad | | | ? | A | A | <CR> | | | | | | | | | | | | | | | |
| | Mess-Bus | | OK | <DLE> | 1 | | | | | | | | | | | | | | | | | |
| | | | Bad | <NAK> | | | | | | | | | | | | | | | | | | |
| | Instrument identification | | | # | A | A | 1 | Y | <CR> | | | | | | | | | | | | | |
| HW identification | | | # | A | A | 1 | Z | <CR> | | | | | | | | | | | | | | |
| One-time transmission | | | # | A | A | 7 | X | <CR> | | | | | | | | | | | | | | |
| Repeated transmission | | | # | A | A | 8 | X | <CR> | | | | | | | | | | | | | | |

9. DATA PROTOCOL

LEGEND

| SIGN | RANGE | DESCRIPTION |
|--------|---------------------------------------|--|
| # | 35 23 _H | Command beginning |
| A | A 0...31 | Two characters of instrument address (sent in ASCII - tens and units, e.g. "01", "99" universal) |
| <CR> | 13 0D _H | Carriage return |
| <SP> | 32 20 _H | Space |
| N, P | | Number and command - command code |
| D | | Data - usually characters "0"..."9"; ":", ";", "(", ")", "dp" and "." may prolong data |
| R | 30 _H ...3F _H | Relay and tare status |
| ! | 33 21 _H | Positive confirmation of command (ok) |
| ? | 63 3F _H | Negative confirmation of command (point) |
| > | 62 3E _H | Beginning of transmitted data |
| <STX> | 2 02 _H | Beginning of text |
| <ETX> | 3 03 _H | End of text |
| <SADR> | adresa +60 _H | Prompt to send from address |
| <EADR> | adresa +40 _H | Prompt to accept command at address |
| <ENQ> | 5 05 _H | Terminate address |
| <DLE>1 | 16 49 10 _H 31 _H | Confirm correct statement |
| <NAK> | 21 15 _H | Confirm error statement |
| <BCC> | | Check sum -XOR |

RELAYS, TARE

| SIGN | RELAY 1 | RELAY 2 | TARE | CHANGE RELAY 3/4 |
|------|---------|---------|------|------------------|
| P | 0 | 0 | 0 | 0 |
| Q | 1 | 0 | 0 | 0 |
| R | 0 | 1 | 0 | 0 |
| S | 1 | 1 | 0 | 0 |
| T | 0 | 0 | 1 | 0 |
| U | 1 | 0 | 1 | 0 |
| V | 0 | 1 | 1 | 0 |
| W | 1 | 1 | 1 | 0 |
| p | 0 | 0 | 0 | 1 |
| q | 1 | 0 | 0 | 1 |
| r | 0 | 1 | 0 | 1 |
| s | 1 | 1 | 0 | 1 |
| t | 0 | 0 | 1 | 1 |
| u | 1 | 0 | 1 | 1 |
| v | 0 | 1 | 1 | 1 |
| w | 1 | 1 | 1 | 1 |

Relay status is generated by command #AA6X <CR>. The instrument immediately returns the value in the format >HH <CR>, where HH is value in HEX format and range 00H...FFH. The lowest bit stands for „Relay 1“, the highest for „Relay 8“

| ERROR | CAUSE | ELIMINATION |
|-----------------|--|--|
| <i>E. d. Un</i> | Number is too small (large negative) to be displayed | change DP setting, channel constant setting |
| <i>E. d. Ou</i> | Number is too large to be displayed | change DP setting, channel constant setting |
| <i>E. t. Un</i> | Number is outside the table range | increase table values, change input setting (channel constant setting) |
| <i>E. t. Ou</i> | Number is outside the table range | increase table values, change input setting (channel constant setting) |
| <i>E. i. Un</i> | Input quantity is larger than permitted input quantity range | change input signal value or input (range) setting |
| <i>E. i. Ou</i> | Input quantity is larger than permitted input quantity range | change input signal value or input (range) setting |
| <i>E. Hu</i> | A part of the instrument does not work properly | send the instrument for repair |
| <i>E. EE</i> | Data in EEPROM corrupted | perform restoration of manufacture setting, upon repeated error statement send instrument for repair |
| <i>E. SEt</i> | Data in EEPROM outside the range | perform restoration of manufacture setting, upon repeated error statement send instrument for repair |
| <i>E. CLr.</i> | Memory was empty (presetting carried out) | upon repeated error statement send instrument for repair, possible failure in calibration |
| <i>E. OUt</i> | Analogue output current loop disconnected | check wire connection |

11. TABLE OF SIGNS



The instrument allows to add two descriptive characters to the classic numeric formats (at the expense of the number of displayed places). The setting is performed by means of a shifted ASCII code. Upon modification the first two places display the entered characters and the last two places the code of the relevant symbol from 0 to 95. Numeric value of given character equals the sum of the numbers on both axes of the table.

Description is cancelled by entering characters with code 00

| | 0 | 1 | 2 | 3 | 4 | 5 | 6 | 7 | | 0 | 1 | 2 | 3 | 4 | 5 | 6 | 7 |
|----|---|---|----|----|----|---|---|---|----|---|---|----|----|---|---|---|---|
| 0 | | Q | " | # | \$ | % | & | ' | 0 | ! | " | # | \$ | % | & | ' | |
| 8 | : | ; | # | + | , | - | . | / | 8 | (|) | * | + | , | - | . | / |
| 16 | 0 | 1 | 2 | 3 | 4 | 5 | 6 | 7 | 16 | 0 | 1 | 2 | 3 | 4 | 5 | 6 | 7 |
| 24 | 8 | 9 | VA | Vr | < | = | > | ? | 24 | 8 | 9 | VA | Vr | < | = | > | ? |
| 32 | P | R | B | C | D | E | F | G | 32 | @ | A | B | C | D | E | F | G |
| 40 | H | I | J | K | L | M | N | O | 40 | H | I | J | K | L | M | N | O |
| 48 | P | Q | R | S | T | U | V | W | 48 | P | Q | R | S | T | U | V | W |
| 56 | X | Y | Z | [| \ |] | ^ | _ | 56 | X | Y | Z | [| \ |] | ^ | _ |
| 64 | ` | a | b | c | d | e | f | g | 64 | ` | a | b | c | d | e | f | g |
| 72 | h | i | j | k | l | m | n | o | 72 | h | i | j | k | l | m | n | o |
| 80 | p | q | r | s | t | u | v | w | 80 | p | q | r | s | t | u | v | w |
| 88 | x | y | z | { | | } | ~ | | 88 | x | y | z | { | | } | ~ | |



Front view

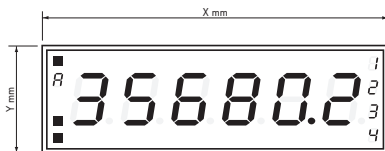

Side view

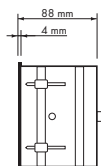

Panel cutout

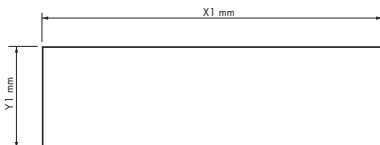

Panel thickness: 0,5 ... 50 mm

| Height | X | Y | X1 | Y1 |
|--------------|-----|-----|-----|-----|
| 57-6 | 375 | 119 | 367 | 111 |
| 100-4 | 465 | 181 | 457 | 173 |
| 100-6 | 651 | 181 | 643 | 173 |
| 125-4 | 539 | 237 | 531 | 228 |
| 125-6 | 754 | 237 | 746 | 228 |

Wall mounting

Our large displays are supplied along with a wall mount holder as shown in the the drawing.

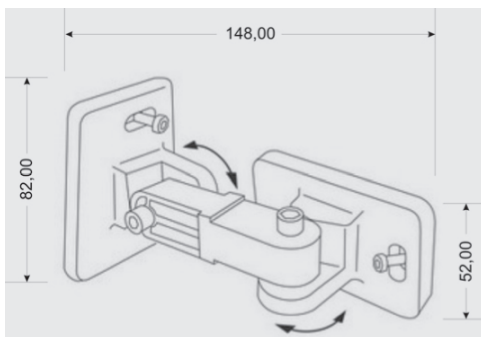

13. TECHNICAL DATA

INPUT

| | | |
|---|---|------------------------|
| range is adjustable | | DC |
| ±60 mV | >100 MΩ | Input U |
| ±150 mV | >100 MΩ | Input U |
| ±300 mV | >100 MΩ | Input U |
| ±1200 mV | >100 MΩ | Input U |
| range is adjustable | | DC - option "A" |
| ±0,1 A | < 300 mV | Input I |
| ±0,25 A | < 300 mV | Input I |
| ±0,5 A | < 300 mV | Input I |
| ±1 A | < 30 mV | Input I |
| ±5 A | < 150 mV | Input I |
| ±100 V | 20 MΩ | Input U |
| ±250 V | 20 MΩ | Input U |
| ±500 V | 20 MΩ | Input U |
| range is adjustable | | PM |
| 0/4...200 mA | < 400 mV | Input I |
| ±2 V | 1 MΩ | Input U |
| ±5 V | 1 MΩ | Input U |
| ±10 V | 1 MΩ | Input U |
| ±40 V | 1 MΩ | Input U |
| range is adjustable | | OHM |
| 0...100 Ω | | |
| 0...1 kΩ | | |
| 0...10 kΩ | | |
| 0...100 kΩ | | |
| Connection: | 2, 3 or 4 wire | |
| Pt xxxx | -200°...850°C | RTD |
| Pt xxxx/3910 ppm | -200°...1 100°C | |
| Ni xxxx | -50°...250°C | |
| Cu/4260 ppm | -50°...200°C | |
| Cu/4280 ppm | -200°...200°C | |
| Type Pt: | EU > 100/500/1 000 Ω, with 3 850 ppm/°C US > 100 Ω, with 3 920 ppm/°C RU > 50/100 Ω, with 3 910 ppm/°C | |
| Type Ni: | Ni 1 000/ Ni 10 000 with 5 000/6 180 ppm/°C | |
| Type Cu: | Cu 50/Cu 100 with 4 260/4 280 ppm/°C | |
| Connection: | 2, 3 or 4 wire | |
| range is adjustable in configuration menu | | T/C |
| Type: | J (Fe-CuNi) -200°...900°C K (NiCr-Ni) -200°...1 300°C T (Cu-CuNi) -200°...400°C E (NiCr-CuNi) -200°...690°C B (PtRh30-PtRh6) 300°...1 820°C S (PtRh10-Pt) -50°...1 760°C R (Pt13Rh-Pt) -50°...1 740°C N (Omegalloy) -200°...1 300°C L (Fe-CuNi) -200°...900°C | |
| | | DU |
| Voltage of lin. pot. | 2,5 VDC/6 mA min. potentiometer resistance is 500 Ω | |

PROJECTION

| | |
|----------------|--|
| Display: | 999999, 4 (100/125 mm) or 6 digit (57/100/125 mm) Three-color 7 segment LED - red/green/orange High bright singles LED - red or green (1300 mcd) |
| Projection: | -999...9999 or -99999...999999 |
| Decimal point: | adjustable - in menu |
| Brightness: | adjustable - in menu |

INSTRUMENT ACCURACY

| | |
|-------------------------|--|
| TC: | 50 ppm/°C |
| Accuracy: | ±0,1% of range + 1 digit ±0,15% of range + 1 digit RTD, T/C Above accuracies apply for projection 9999 |
| Resolution: | 0,01°/0,1°/1° RTD |
| Rate: | 0,1...40 measurements/s** |
| Overload capacity: | 10x (t < 100 ms) not for 500 V and 5 A, 2x (long-term) |
| Linearisation: | by linear interpolation in 50 points - solely via OM Link |
| Digital filters: | Averaging, Floating average, Exponential filter, Rounding |
| Comp. of conduct: | max. 40 Ω/100 Ω RTD |
| Comp. of cold junction: | adjustable T/C |
| Functions: | 0°...99°C or automatic Tare - display resetting Hold - stop measuring (at contact) Lock - control key locking MM - min/max value Mathematic functions |
| OM Link: | company communication interface for setting, operation and update of instrument SW |
| Watch-dog: | reset after 400 ms |
| Calibration: | at 25°C and 40% of r.h. |

COMPARATOR

| | |
|-------------|---|
| Type: | digital, adjustable in menu |
| Mode: | Hysteresis, From, Dosing |
| Limita: | -99999...999999 |
| Hysteresis: | 0...999999 |
| Delay: | 0...99,9 s |
| Outputs: | 4x relays with switch-on contact (Form A) (230 VAC/30 VDC, 3 A)* 4x open collectors (30 VDC/100 mA) |
| Relay: | 1/8 HP 277 VAC, 1/10 HP 125 V, Pilot Duty D300 |

* values apply for resistance load



DATA OUTPUTS

Protocols: ASCII, DIN MessBus, MODBUS, PROBUS
 Data format: 8 bit + no parity + 1 stop bit (ASCII)
 7 bit + even parity + 1 stop bit (MessBus)
 Rate: 600...230 400 Baud
 9 600 Baud...12 Mbaud (PROFIBUS)
 RS 232: isolated, two-way communication
 RS 485: isolated, two-way communication,
 addressing (max. 31 instruments)
 PROFIBUS Data protocol SIEMENS

ANALOG OUTPUT

Type: isolated, programmable with 12 bits D/A converter,
 analog output corresponds with displayed data,
 type and range are adjustable
 Non-linearity: 0,1 % of range
 TC: 15 ppm/°C
 Rate: response to change of value < 1 ms
 Voltage: 0...2 V/5 V/10 V/±10 V
 Current: 0...5/20 mA/4...20 mA
 - compensation of conduct to 500 Ω /12 V
 or 1 000 Ω/24 V

EXCITATION

Adjustable: 5...24 VDC/max. 1,2 W, isolated

POWER SUPPLY

Options: 10...30 V AC/DC, max. 27 VA, isolated
 PF ≥ 0,4, I_{STP} > 75 A/2 ms fuse inside (T 4A)
 80...250 V AC/DC, max. 27 VA, isolated
 PF ≥ 0,4, I_{STP} > 475 A/2 ms fuse inside (T 4A)

MECHANIC PROPERTIES

Material: anodized aluminum, black
 Dimensions: see chapter 13
 Panel cut-out: see chapter 13

OPERATING CONDITIONS

Connection: through cable bushings to terminal boards inside the instrument, conductore section up to < 1,5 mm² /< 2,5 mm²
 Stabilisation period: within 15 minutes after switch-on
 Working temp.: -20°...60°C
 Storage temp.: -20°...85°C
 Cover: IP64
 Construction: safety class I
 Overvoltage cat.: EN 61010-1, A2
 Dielectric strength: 4 kVAC after 1 min between supply and input
 4 kVAC after 1 min between supply and analog output
 4 kVAC after 1 min between supply and relay output
 2,5 kVAC after 1 min between supply and analog output
 Insulation resist.: for pollution degree II, measurement category III
 instrum.power supply > 670 V (PI), 300 V (DI)
 Input/output > 300 V (PI), 150 (DI)
 EMC: EN 61326-1

**Table of rate of measurement in relation to number of inputs

| Channels/Rate | 40 | 20 | 10 | 5 | 2 | 1 | 0,5 | 0,2 | 0,1 |
|--|-------|-------|-------|------|------|------|------|------|------|
| No.of channels: 1 (Type: DC, PM, DU) | 40,00 | 20,00 | 10,00 | 5,00 | 2,00 | 1,00 | 0,50 | 0,20 | 0,10 |
| No.of channels: 2 | 5,00 | 2,50 | 1,25 | 1,00 | 0,62 | 0,38 | 0,22 | 0,09 | 0,05 |
| No.of channels: 3 | 3,33 | 1,66 | 0,83 | 0,66 | 0,42 | 0,26 | 0,14 | 0,06 | 0,03 |
| No.of channels: 4 | 2,50 | 1,25 | 0,62 | 0,50 | 0,31 | 0,19 | 0,11 | 0,05 | 0,02 |
| No.of channels: 1 (Type: OHM, RTD, T/C) | 5,00 | 2,50 | 1,25 | 1,00 | 0,62 | 0,38 | 0,22 | 0,09 | 0,05 |
| No.of channels: 2 | 3,33 | 1,66 | 0,83 | 0,66 | 0,42 | 0,26 | 0,14 | 0,06 | 0,03 |
| No.of channels: 3 | 2,50 | 1,25 | 0,62 | 0,50 | 0,31 | 0,19 | 0,11 | 0,05 | 0,02 |
| No.of channels: 4 | 2,00 | 1,00 | 0,50 | 0,40 | 0,25 | 0,15 | 0,08 | 0,04 | 0,02 |

PI - Primary insulation, DI - Double insulation

14. CERTIFICATE OF GUARANTEE



Product **OMD 202UNI** **A**
Type
Manufacturing No.
Date of sale

WARRANTY

A guarantee period of 60 months from the date of sale to the user applies to this instrument.
Defects occurring during this period due to manufacture error or due to material faults shall be eliminated free of charge.

For quality, function and construction of the instrument the guarantee shall apply provided that the instrument was connected and used in compliance with the instructions for use.

The guarantee shall not apply to defects caused by:

- mechanic damage
- transportation
- intervention of unqualified person incl. the user
- unavoidable event
- other unprofessional interventions

The manufacturer performs guarantee and post.guarantee repairs unless provided for otherwise.

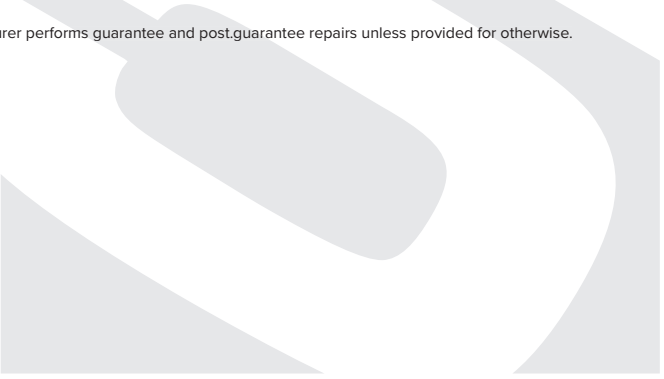

Y E A R S

Stamp, signature

| | |
|---------------------|--|
| Company | ORBIT MERRET, spol. s r.o. Klánova 81/141, 142 00 Prague 4, Czech Republic, IDNo.: 00551309 |
| Manufactured | ORBIT MERRET, spol. s r.o. Vodňanská 675/30, 198 00 Prague 9, Czech Republic |

declares at its explicit responsibility that the product presented hereunder meets all technical requirements, is safe for use when utilised under the terms and conditions determined by ORBIT MERRET, spol.s r.o. and that our company has taken all measures to ensure conformity of all products of the types referred-to hereunder, which are being brought out to the market, with technical documentation and requirements of the appurtenant Czech statutory orders.

| | |
|----------------|--------------------------------------|
| Product | 4/6-digit programmable large display |
| Type | OMD 202 |
| Version | UNI, PWR, UQC, RS |

This has been designed and manufactured in line with requirements of

Low-voltage electrical equipment (directive no. 2014/35/EU)
Electromagnetic compatibility (directive no. 2014/30/EU)

The product qualities are in conformity with harmonized standard

| | |
|-------------|--|
| El. safety: | EN 61010-1 |
| EMC: | EN 61326-1 Electronic measuring, control and laboratory devices – Requirements for EMC “Industrial use” EN 50131-1, cap. 14 and cap. 15, EN 61000-4-2, EN 61000-4-3, EN 61000-4-4, EN 61000-4-5, EN 61000-4-6, EN 61000-4-8, EN 61000-4-11, EN 61000-3-2, EN 61000-3-3, EN 55022, cap. 5 and cap. 6 |

The product is furnished with CE label issued in 2001.

As documentation serve the protocols of authorized and accredited organizations

| | |
|-----|--|
| EMC | VTÚE Praha, experimental laboratory No. 1158, protocol No. 08-041/2001 of 24/11/2001 VTÚPV Vyškov, experimental laboratory No. 1103, protocol No. 730-325/2001 of 02/05/2001 VTÚPV Vyškov, experimental laboratory No. 1103, protocol No. 730-350/2001 of 07/05/2001 VTÚPV Vyškov, experimental laboratory No. 1103, protocol No. 730-372/2001 of 02/05/2001 VTÚPV Vyškov, experimental laboratory No. 1103, protocol No. 730-934/2001 of 20/11/2001 |
|-----|--|

Place and date of issue: Prague, 19. Juli 2009

Miroslav Hackl
Company representative

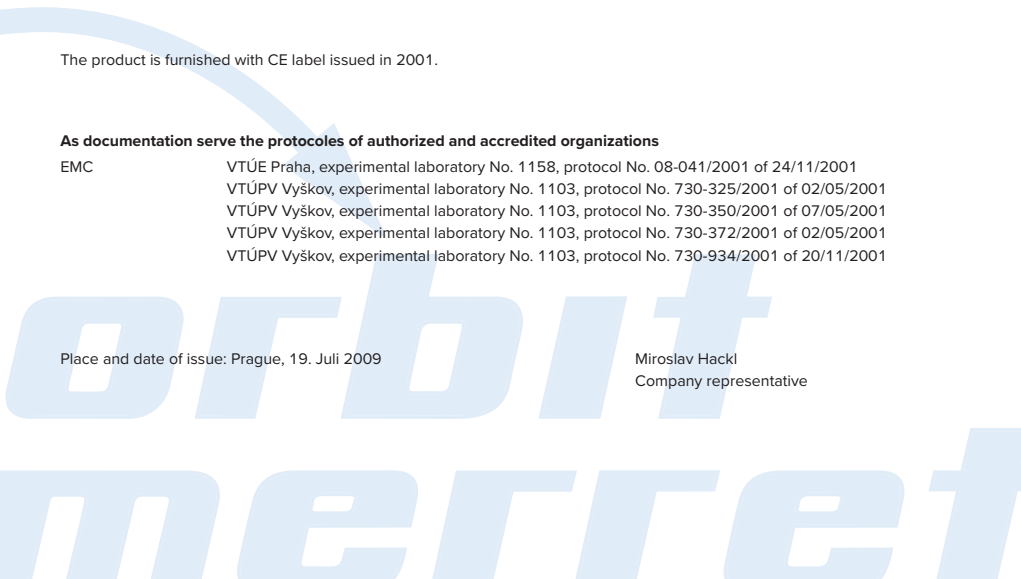



ORBIT MERRET, spol. s r. o.
Vodňanská 675/30
198 00 Praha 9
Czech Republic

tel.: +420 281 040 200
fax.: +420 281 040 299
e-mail: orbit@merret.eu

www.orbit.merret.eu

