

Programming diagram of the LIGHT MENU

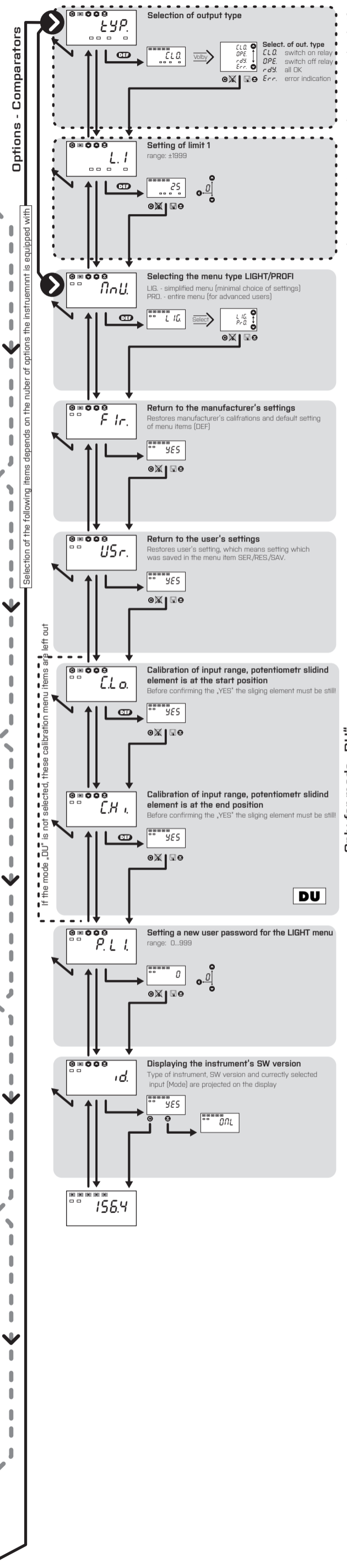
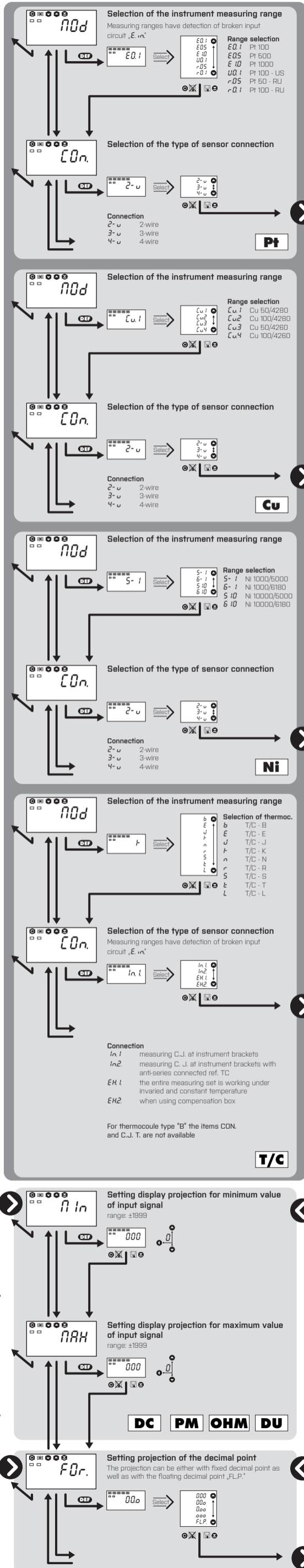
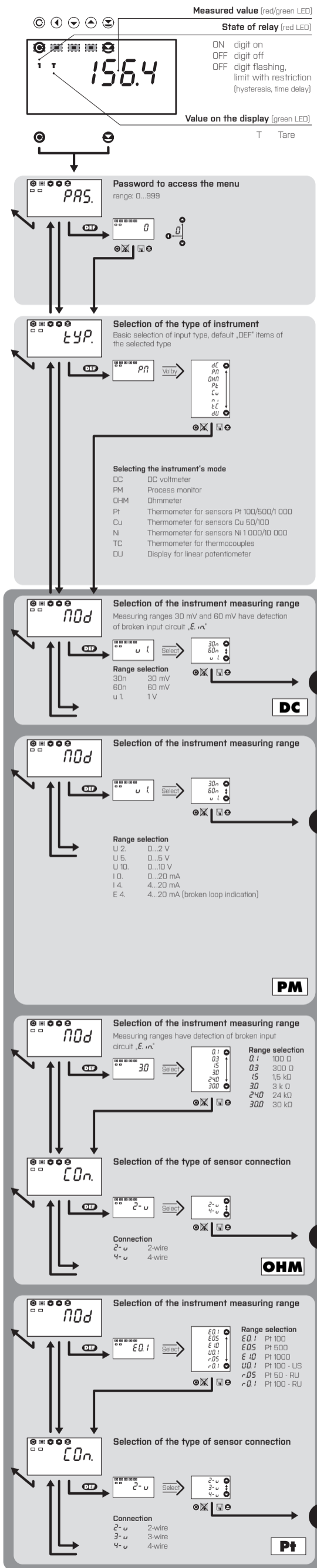

Selection of the following items depends on the number of options the instrument is equipped with

If the mode „DU“ is not selected, these calibration menu items are left out

These menu items can be accessed only if the instrument contains corresponding options

Only for mode „DU“

Programming diagram of the PROFI MENU

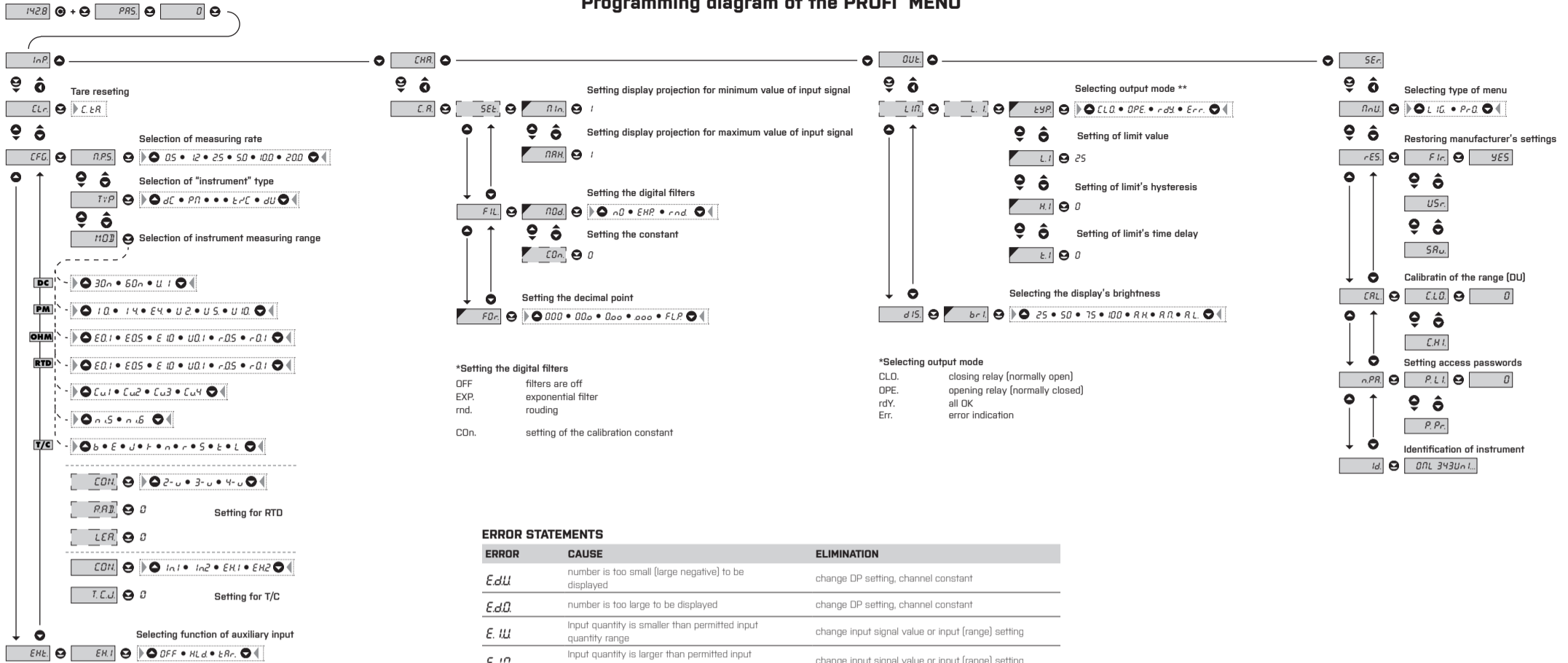

\*Setting the digital filters  
 OFF filters are off  
 EXP. exponential filter  
 md. rounding  
 CDn. setting of the calibration constant

\*Selecting output mode  
 CLQ. closing relay (normally open)  
 OPE. opening relay (normally closed)  
 rdY. all OK  
 Err. error indication

ERROR STATEMENTS

ERROR	CAUSE	ELIMINATION
E.dU	number is too small (large negative) to be displayed	change DP setting, channel constant
E.dQ	number is too large to be displayed	change DP setting, channel constant
E. IU	Input quantity is smaller than permitted input quantity range	change input signal value or input (range) setting
E. IQ	Input quantity is larger than permitted input quantity range	change input signal value or input (range) setting
E.Hu	a part of the instrument does not work properly	send the instrument for repair
E.EE	data in EEPROM corrupted	perform restoration of manufacture setting, upon repeated error statement send instrument for repair
E.dE	data in EEPROM outside the range	perform restoration of manufacture setting, upon repeated error statement send instrument for repair
E.CL	memory was empty (presetting carried out)	upon repeated error statement send instrument for repair, possible failure in calibration
E.in	disconnected input circuit	check wiring

! Upon delay exceeding 60 s the programming mode is automatically discontinued and the instrument itself restores the measuring mode

CONNECTING AND CONTROLLING OF INSTRUMENT

TECHNICAL DATA

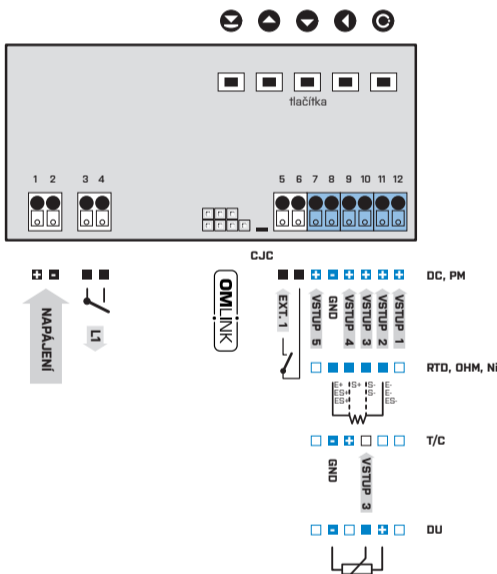

Power supply cord should not be near low voltage input signal leads.

Contactors, large electrical motors and other power elements should not be operated in the vicinity of the instrument.

Input signal leads (measured value) should be separated from all power devices. If this is not possible to provide, the input leads have to be shielded and the shielding grounded (terminal E).

Our instruments are extensively tested and they comply with relevant standards for use in industrial environment, however, adhering to the above mentioned measures is strongly advised.

MEASURING RANGES - CONNECTION

TYPE	INPUT 1	INPUT 2	INPUT 3	INPUT 4	INPUT 5
DC	0...1 V		0...60 mV	0...20 mV	
PM	0...5/10 V			0...20 mA	0/4...20 mA
OHM	0...300 Ω/0...15 kΩ/0...3 kΩ/0...30 kΩ				
RTD-PT	Pt 100/Pt 500/Pt 1 000				
RTD-CU	Cu 50/Cu 100				
RTD-NI	Ni 1 000/Ni 10 000				
T/C	J/K/T/E/B/S/R/N/L				
DU	Linear potentiometer (min. 500 Ω)				

EXTERNAL INPUT

EXT. 1	DESCRIPTION	CONTROLS
EXT. 1	controlling input, its function is set in the menu (see. Menu > EXT. IN.)	upon contact, terminal (No. 5 + 6)

MEASURING INPUT

INPUT	Range	Accuracy	Resolution	Input Impedance
DC	±20 mV	> 10 MΩ	Input 4	
	±60 mV	> 10 MΩ	Input 3	
	±1 000 mV	1,25 MΩ	Input 1	
PM	0/4...20 mA	< 200 mV	Input 5	
	0...2 V	> 10 MΩ	Input 4	
	0...5 V	1,25 MΩ	Input 1	
OHM	0...300 Ω		Input 1	
	0...15 kΩ			
	0...3 kΩ			
RTD	EU > 100/500/1 000 Ω, with 3 850 ppm	-50°...450°C		
	US > 100 Ω, with 3 920 ppm/°C	-50°...450°C		
	RU > 50/100 Ω with 3 910 ppm/°C	-200°...1 100/450°C		
Ni	Ni 1 000/ Ni 10 000 with 5 000 ppm/°C	-50°...250°C		
	Ni 1 000/ Ni 10 000 with 6 180 ppm/°C	-200°...250°C		
Cu	Cu 50/Cu 100 with 4 260 ppm/°C	-50°...200°C		
	Cu 50/Cu 100 with 4 280 ppm/°C	-200°...200°C		
T/C	J (Fe-CuNi)	-200°...900°C		
	K (Ni-Cr-Ni)	-200°...1 300°C		
	T (Cu-CuNi)	-200°...400°C		
	E (Ni-CuNi)	-200°...690°C		
	B (PtRh30-PtRh6)	300°...1 820°C		
	S (PtRh10-Pt)	-50°...1 760°C		
	R (PtRh30-Pt)	-50°...1 740°C		
	N (Omega alloy)	-200°...1 300°C		
L (Fe-CuNi)	-200°...900°C			
DU	Lin. pot. supply	2,5 VDC/6 mA, min. potentiometer resistance is 500 Ω		

INSTRUMENT'S ACCURACY

TK	50 ppm/°C
Accuracy	±0,15% of the range + 1 digit ±0,3% of the range + 1 digit [T/C]
Accuracy of cold junction measurement:	±0,1°C
Rate	0,5...20 measurements/s
Overload capacity:	10x (t < 30 ms) - not for > 200 V and 5 A; 2x
Resolution	0,1°C (RTD), 1°C (T/C)
Data back-up	stores the measured value after the device has been switched off [EEPROM]
Digital filters	exponential filter, rounding
Functions	Hold - "freezing the measured value", Lock - blocking the control buttons, Tare (upon contact)
External inputs	1, with the possibility of assigning various functions in the instrument's menu
OM Link	Company communication interface for operating, setting and updating of instruments
Watch-dog	reset after 500 ms
Calibration	at 25°C and 40% rv.

PROJECTION

Display	1999, red or green 7-segment LED, digit height 14 mm
Projection	±1999
Decimal point	setting - in menu
Brightness	0%, 25%, 50%, 75%, 100% [selectable in the menu] or automatically at three steps Auto. H, Auto. M and Auto. L

COMPARATOR

Type	digital, menu selectable
Mode	Hysteresis, Once, Pulse
Limit	±1999
Hysteresis	0...1999
Delay	0...99,9 s
Output	1x relay with a switch on contact (Form A), [250 VAC/30 VDC, 3 A]* 1x open collector; [30 VDC/100 mA]*
Relay	1/8 HP 277 VAC, 1/10 HP 125 V, Pilot Duty D300

POWER SUPPLY

	10...30 VDC/24 VAC, ±10%, 3 VA, isolated
--	--

MECHANICAL PROPERTIES

Material	Noryl GFN2 SE1, incombustible UL 94 V-1
Dimensions	98 x 48 x 30 mm
Panel cut out	92 x 44 mm

ENVIRONMENTAL

Connection	terminal board, section < 1,5 mm <sup>2</sup>
Stabilization period	15 minutes after switch on
Working temperature	-20°...60°C
Storage temperature	-20°...85°C
Cover	IP65 (front panel only), rear of the instrument is open!
Provideni	security class I
EL safety	EN 61010-1, A2
Dielectric strength	2,5 kVAC after 1 min between supply and input 4 kVAC after 1 min between supply and relay output
Insulation resistance*	for pollution degree II, measuring cat. III, power supply > 300 V [Pi] input, output > 300 V [Di]
EMC	EN 61326-1 [Industrial area]

PI - Primary insulation, DI - Double insulation

MOUNTING AND DIMENSIONS

Mounting the instrument

1. insert the instrument into the panel cutout
2. insert the fixing sliders into side grooves of the enclosure as shown
3. press the sliders tightly against the rear side of the panel

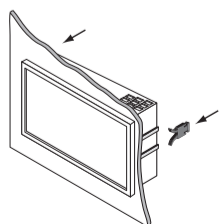

Removal of the instrument

1. pry the rear end of the sliders away from the instrument's enclosure
2. slide the fixing sliders out of side grooves of the enclosure as shown
3. remove the instrument from the panel cutout

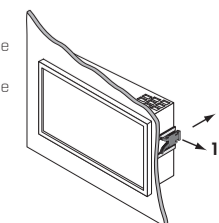

Front view

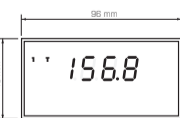

Side view

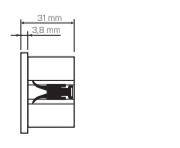

Panel cut

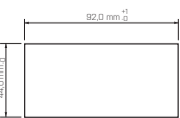

Panel thickness: 0,1-3,5mm



ORBIT MERRET, spol. s r.o.  
 Vodnanská 675/30  
 198 00 Praha 9  
 Czech republic  
 Tel: +420 - 281 040 200  
 Fax: +420 - 281 040 299  
 e-mail: orbit@merret.cz  
 www.orbit.merret.cz