

Paperless recorder OMR 700

User guide

© 2017 Orbit Merret

Version: 1.0.31
February 2017

1. Introduction	5
2. Control Panel	8
3. Login	14
4. Menu	16
5. Input and data processing	22
5.1 Input and output cards	23
5.1.1 Channel settings	25
5.2 Timers	26
5.3 Constants	27
5.4 Nodes	28
5.4.1 Generator	30
5.4.2 Comparator	31
5.4.3 IO buffer	33
5.4.4 Logical functions	34
5.4.5 Mathematical functions	36
5.4.6 Limits and Outputs	37
5.5 Fieldbuses	39
5.5.1 Modbus TCP Slave	39
5.5.2 Fieldbus browser	40
6. Output and graphics	42
6.1 Groups	43
6.1.1 Adding items into group	44
6.1.2 Item Editing	45
6.2 Screens	46
6.2.1 Graphics configuration	49
6.2.2 Setting style and parameters	51
6.3 Records	54
6.3.1 Adding parameters	56
6.4 Events	57
6.4.1 Causes	58
6.4.2 Effects	59
6.4.3 Event Browser	60
7. Parameter selection window	62
7.1 Parameter "Not used"	64
7.2 Parameters from the I/O cards	65
7.3 Parameters from the nodes	66

7.4	Parameters from the constants	68
7.5	Parameter value	69
8.	Selecting item from a group	70
9.	Date and time settings	73
10.	Timezone settings	75
11.	Language settings	77
12.	Diagnostics	79
12.1	I/O Cards	80
12.1.1	Card diagnostics	81
12.1.2	Diagnostics of the card registers	83
12.2	Secondary Core	84
12.3	Connection	85
12.4	Storage	87
13.	Device software update	89
14.	I/O Card update	92
15.	User administration	95
16.	Warning, error and critical error	100
16.1	Warning or error details	101
17.	Display settings	104
18.	Sound settings	106
19.	Configuration management	108
20.	Storage management	112
21.	Connection settings	115
21.1	Ethernet	116
21.2	USB Ethernet	118
21.3	WiFi	120
22.	Startup	121
23.	I/O Card calibration	123
24.	Rescue mode	126

25. Examples	129
25.1 Example 2: Voltage measurement with IN.1 card	130
25.2 Example 3: Controlling a relay with a comparator	139
25.3 Example 4: Recording measured values	143
25.4 Example 5: Recording on button click	146
25.5 Example 6: Reading voltage through Modbus TCP	149

1 Introduction

Basic building blocks of the OMR700

Functionality of the paperless recorder OMR700 is based on the following parts:

- a) Inputs and outputs
- b) Nodes
- c) Screens
- d) Records
- e) Timers
- f) Constants

Inputs and outputs – they come from the IC cards (fixed B1 or expanding A1 - A4, B2 - B5). They themselves contain conversions.

Nodes – mathematical or other calculations with the goal of providing requested adjustments of the measured signals or preparation of the output values.

Screens – graphical representation of the measured or calculated values on the recorder display.

Records – what, where, how often, in what format, and other parameters of measured or calculated data for recording.

Timers – provide periodic execution of linked blocks with a given period.

Constants – spontaneously unchangeable named values for further use.

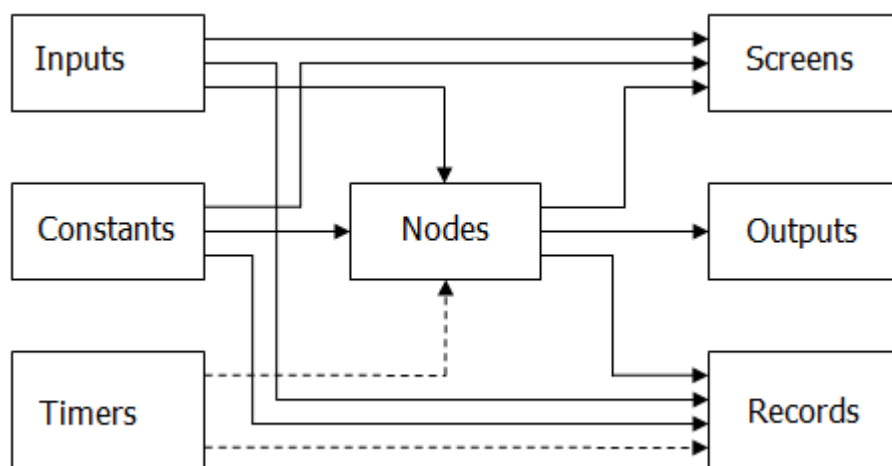

Block chart of the recorder

From the block chart it is apparent that the central point of the recorder is created by the **nodes**. They process the measured inputs, constants, other nodes, and using the preset calculations they calculate a new value. The calculation is kept in time by the timer. The calculated values of the nodes can be displayed on the screen and recorded

on the media. The outputs can also be equipped by them.

An important feature of the nodes is the fact that they can have a history (they remember previous values). This is an optional configuration offering the advantage of displaying the value of the node with its history (running chart).

Timers have an optional setting period. The client can set the period within the range of 1ms up to 40 days (by 1ms, while the dialog limits the settings to the order of ms, s, minutes, hours, and days). There are N timers in the recorder (8 at the moment) so that it is necessary to choose a proper setting for each timer to cover the needs of the entire recorder. The timers control calculations of the nodes and recording on the media, while the internal mechanism guarantees that the nodes are calculated first and only then the new values are recorded on the media.

Inputs and Outputs provide rate, which is different for each type of the card and even for each register on the card. The IC cards are in fact designed as intelligent ones = they conduct their operations in order to relieve the main processor. They are organized into a set of registers. Some of the registers are configurable (e.g. those of input range), some are designated for measured values under different phases of processing. A typical input card provides several values for each input – direct input value of the converter (converter bits), value converted into electrical value (e.g. mA), and the resulting converted value (e.g. in case of weight, the strain gauge input card recalculates the voltage of the strain gauge into weight by a preset formula - range, tare). Similarly, it is possible to control also the outputs. For example: You set the requested turns of a ventilator and the card will itself, according to the preset parameters, recalculate the measured value into voltage and set it on its output.

Constants are designated for easy and well-arranged changes of the settings, e.g. of the required values, filtration parameters... On one place the value can be changed, used for calculations, displayed and recorded.

Screens are used for displaying the measured values. There are N screens (16 at the moment) and each of them can occupy up to M (25 at the moment) different elements like running chart, bar chart, normal text value, finger measuring indicator... You set the element type, size, location, number of displayed values, color, range... So you can build very diverse screens. The redraw period is set in such a manner that it enables a smooth and fast enough drawing, which, at the same time, relieves the main processor. Some elements (as e.g. the running chart) display, besides the current values, also their previous ones. By these elements it is therefore advantageous if the displayed node has a history that is used for filling up the chart when switching over to the screen.

Records serve for recording values on the media. There are N of them (16 at the moment). To each record you can assign a name, frequency, file format, number of records in the file, where you want to record, and, of course, what you want to record (max. 16 values at the moment). All records can be viewed in the record browser. They can also be downloaded to a PC and displayed there.

2 Control Panel

In the upper part of the display there is a dark blue Control Panel. It shows the main control elements.

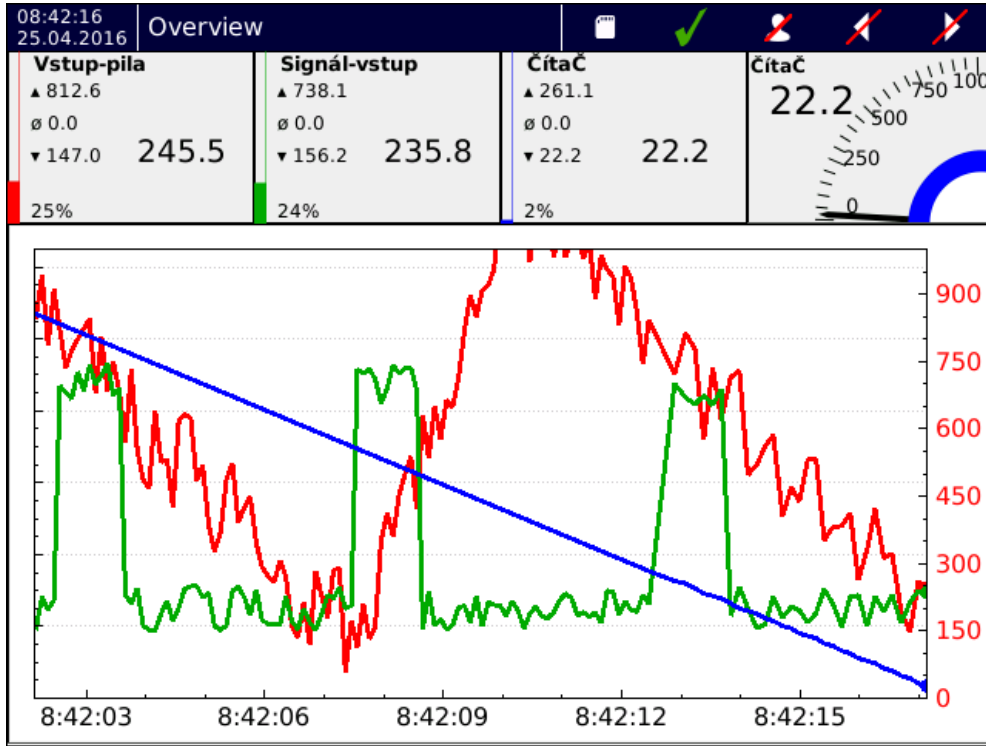

Main screen after switching on the recorder

Panel without a logged-in user

The appearance of the bar without a logged-in user. Control buttons are disabled and therefore you cannot enter the menu, view errors, logs or open the storage media diagnostics. By default screen switching is also disabled.



Control panel without a logged user

Panel with a logged-in user - level "User"

User with access rights "User" has the right of switching over screens, viewing errors, logs and memory media.



Control panel with a logged user

Panel with a logged-in user - level "Operator" and higher

User with access rights "Operator" and higher has, in addition, access to the menu.



Control panel with a logged user

Time and date

Indication of the current time and date.

10:27:43
26.01.2016

Time and date

Name of the currently displayed screen

Space in the control bar, which shows the name of the currently displayed screen.

Screen 0

Name of the currently displayed screen

Click into this space opens the offer with an overview of all defined screens for a fast screen selection.

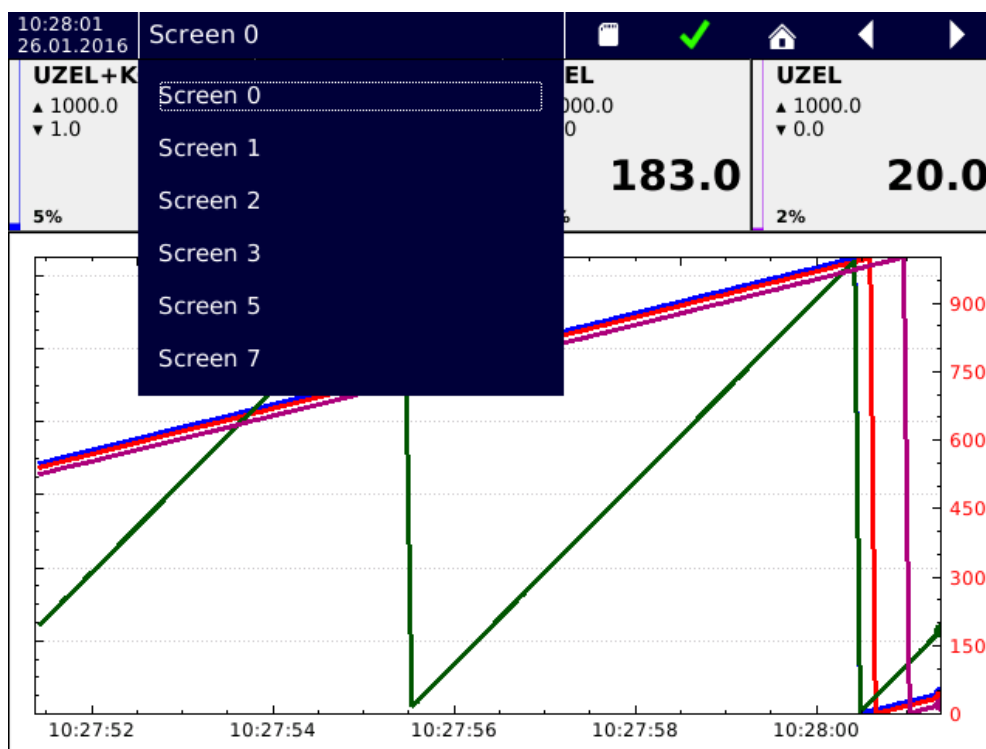

Overview of the memory media



Storage media state. On standby, the icon is white. While recording, the icon changes color according to remaining available storage capacity. If there is enough free space left, the icon is green. When any of the media is at least 80% full, the icon's color will change to yellow. After reaching 90% the icon turns red.

The icon can also be used to open storage media diagnostics.

State of the recorder

Recorder always operates in one of its four states.



State "OK" - the device works without any issues.



State "Warning" - the device operates outside the specified values, but without consequences on its functioning. This state can be caused for instance by an undervoltage greater than 10%, by filling the memory in excess of 80%, and by many other causes. If the device returns within the specified values, "Warning" state will disappear and the log record will be carried out.



State "Error" - device outside the specified values, but with possible consequences on its functioning. This state can be caused for instance by an undervoltage greater than 20%, by filling the memory in excess of 90%, and by many other causes. At the "Error" state an error window is displayed, through which you can view the errors. If the device returns within the specified values, "Error" state will disappear and the log record will be carried out.

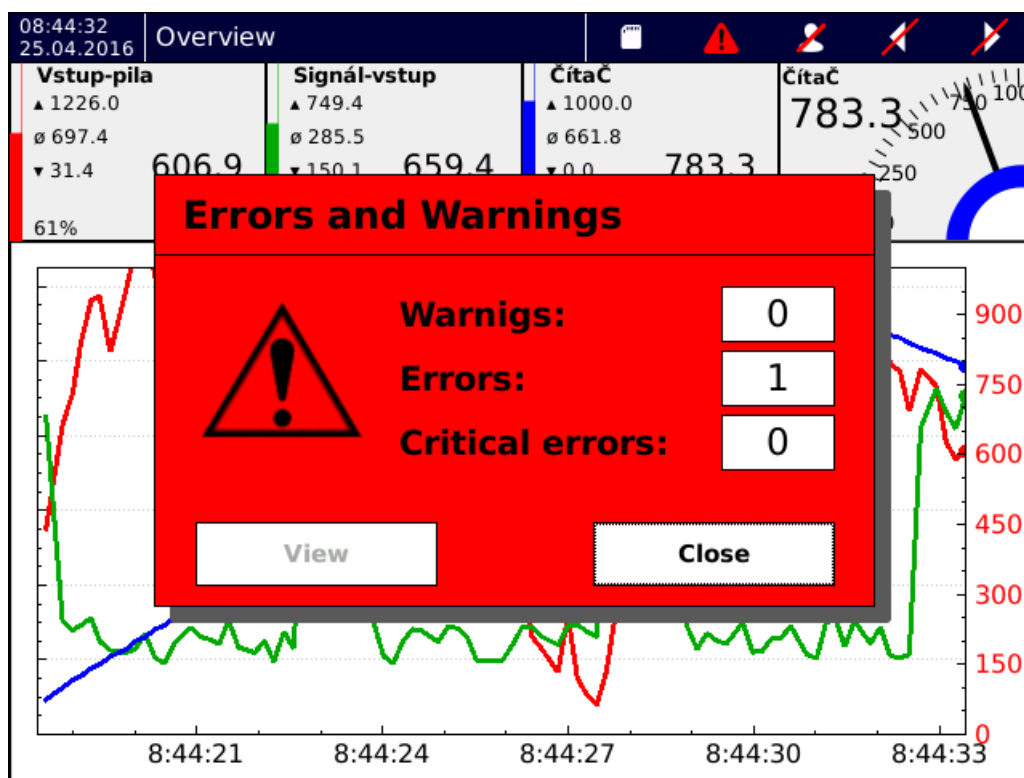

Errors and warnings window showing one detected error.



State "Critical error" - device outside the specified values with consequences on its functioning. This state can be caused for instance by an undervoltage greater than 50% or by filling the memory up to 100 % so that it is not possible to make records. At the "Critical error"

state an error window is displayed, through which you can view the errors. If the device returns within the specified values, both "Critical error" and the error window remain displayed until a confirmation (acknowledgment) of the "Critical error" is done. After confirmation the log record will be carried out.

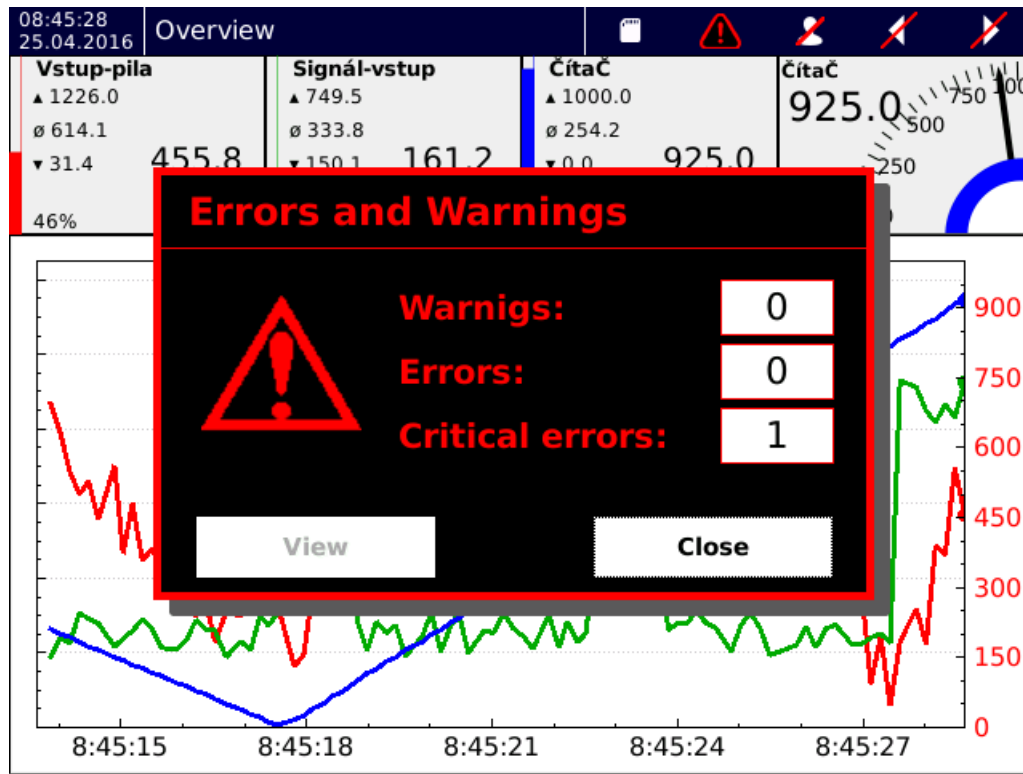

Errors and warnings window showing one detected critical error.

More details about the states of the recorder can be found in the chapter Errors and Warnings.

User login or entry into the menu



Not logged in - no one is logged in and the function keys are disabled. The icon is used to open the log-in dialog.



Logged in on the level "User" - the icon is used for the user log-out.



Logged in on the level "Operator" and higher - the icon is used to enter the menu.

Switching the previous or the next screen



Switching to the next screen. If you have defined only one screen, the screen remains unchanged.





Switching to the previous screen. If you have defined only one screen, the screen remains unchanged.

3 Login

Principle

In the recorder factory setting the device can be logged with the name **UNIVERSAL**, which can create another user profiles and configure all the device functions. Access password is sent together with the delivery note.

Login dialogue

1. **Name** - from the list of created user names kindly select the one, under which you want to log-in.
2. **Level** - level of access rights of the selected user.
3. **Password** - click on the blank field and enter a password to log-in.
4.  - button "Confirm" - it confirms the login. If the password is OK, the dialogue disappears and the icon in the control bar will change. If the password is incorrect, an error window will appear. You can close it and start the login dialogue again.
5.  - button "Cancel" - it will close the login dialogue.

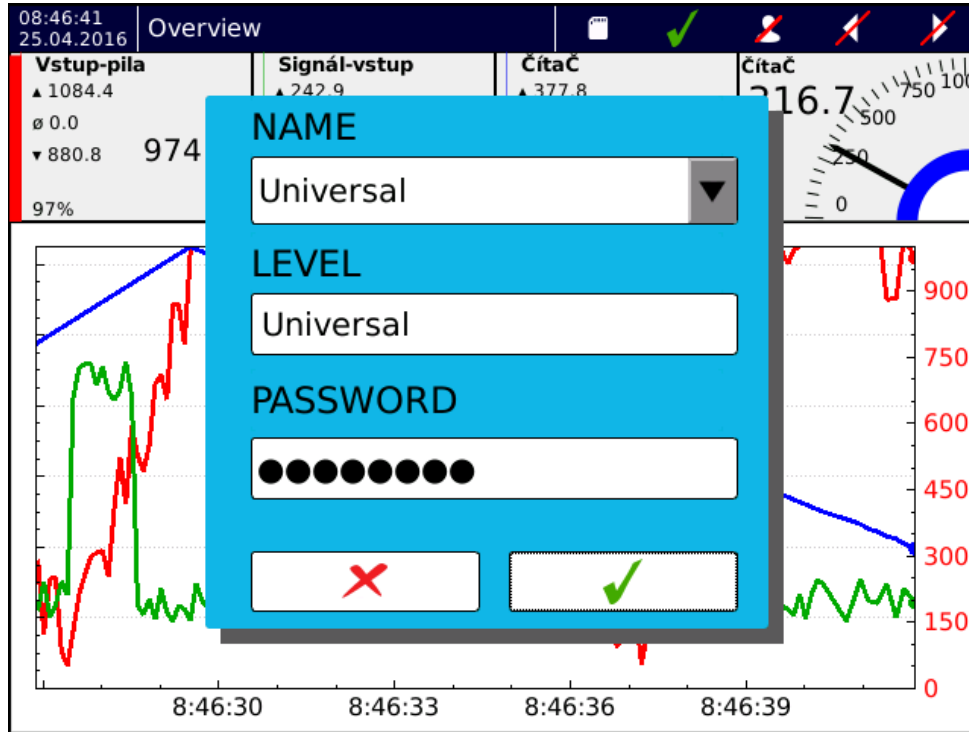

Login dialogue

4 Menu

Menu of the recorder is divided into three basic groups:

1. **Device settings** - basic settings of the OMR 700 such as time and date, language, connection, users, sounds and display, etc.
2. **Setting functions** - setting the computing part of the OMR700. Here you will find settings for the input and output cards, timers, named constants, nodes, groups, records, and graphics.
3. **Viewing** - instruments for viewing measured data, errors and warnings, recorded logs, and for diagnostics of the recorder.

Device settings:



Date and time settings.



Timezone settings.



Language settings.



Network connection settings (Ethernet, USB, WiFi).



Device software update. Used to update device firmware and system.



Card firmware update. Used to update I/O card firmware.



User settings. Dialog for creating and managing user profiles.



Display settings.



Configuration management. Dialog for managing configuration files.



Sound settings.



Button settings (Not yet available)



Basic information about the device.



Alarms settings (Not yet available)



Report settings (Not yet available)



Custom card calibration.

Setting functions:



I/O card settings. Used to configure I/O card parameters.



Timer settings. Creating and managing timers for further use with the device settings.



Named constants setting. Creation and management of named constants.



Nodes setting. Creation and management of the nodes.



Groups setting. Creation and management of the groups of any functional elements, e.g. nodes and input or output channels.



Records setting. Creation and management of the records for recording and backup of the measured data.



Screens setting. Creation and management of the screens for graphical display of the measurement data.



Event settings. Manages user-configurable triggers.



Fieldbus settings. Remote communication and data transfer using protocols such as Modbus.

Viewing:



Viewing the stored values of the entries recorded in the internal memory.



Functionality diagnostics. Diagnostics of the secondary core running, and functions of the plug-in cards.



Viewing warnings, errors and their acknowledgment.



Viewing logs.



Input value statistics.

Upper bar:



Switches to the menu setting.



Switches to the storage diagnostics.



Storing records - turn on/off. If recording is active, the button is green.



Mathematical functions - turn on/off. If calculations are active, the button is green.



User logout.

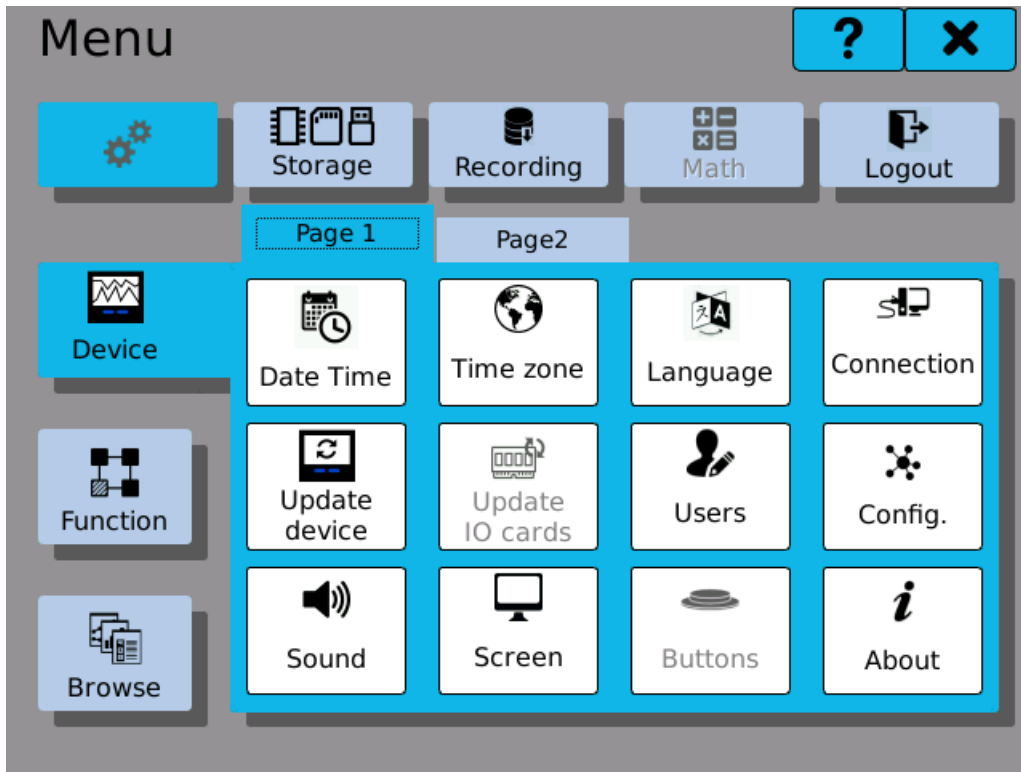

Device Menu - page 1

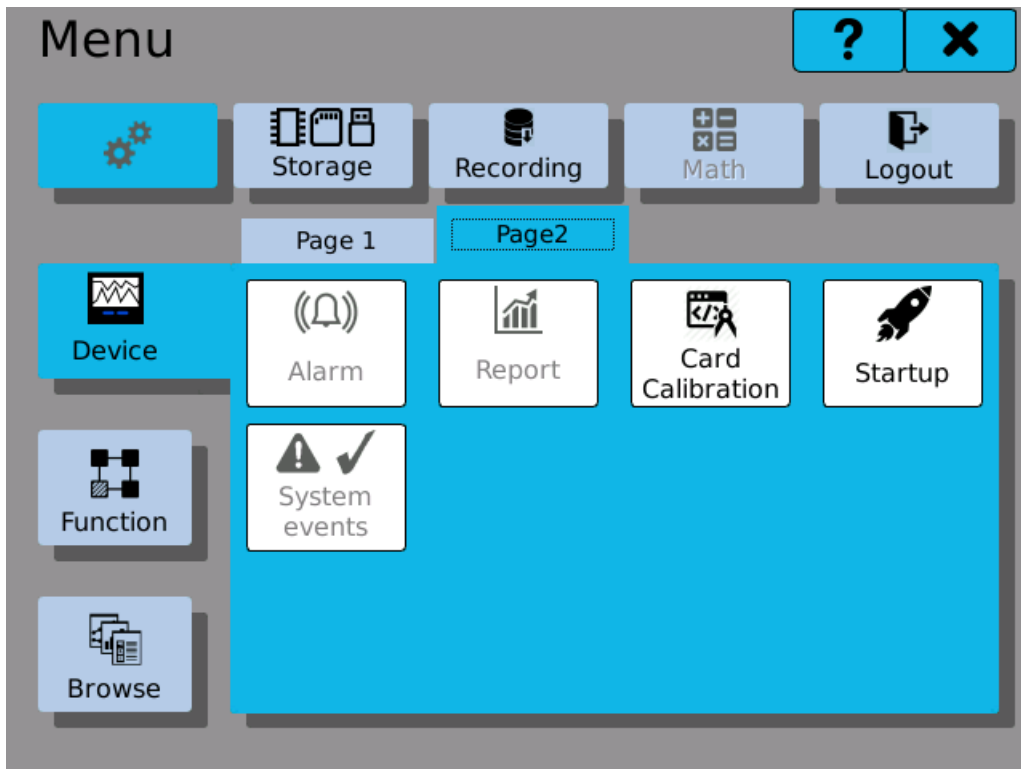

Device Menu - page 2

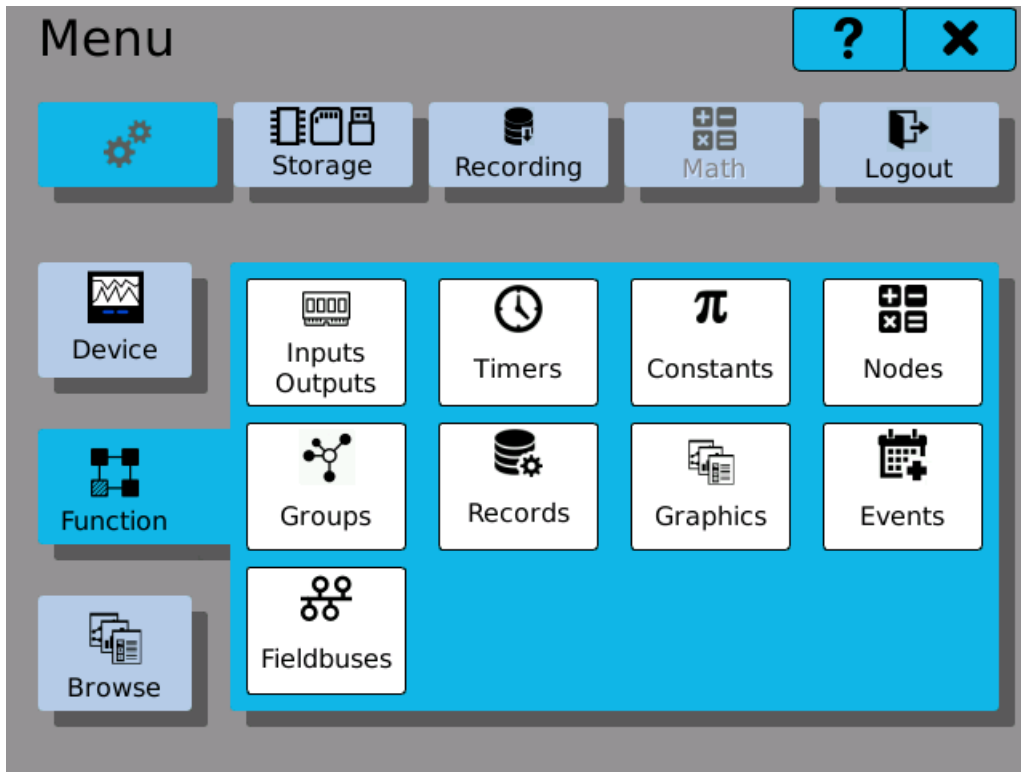

Function Menu

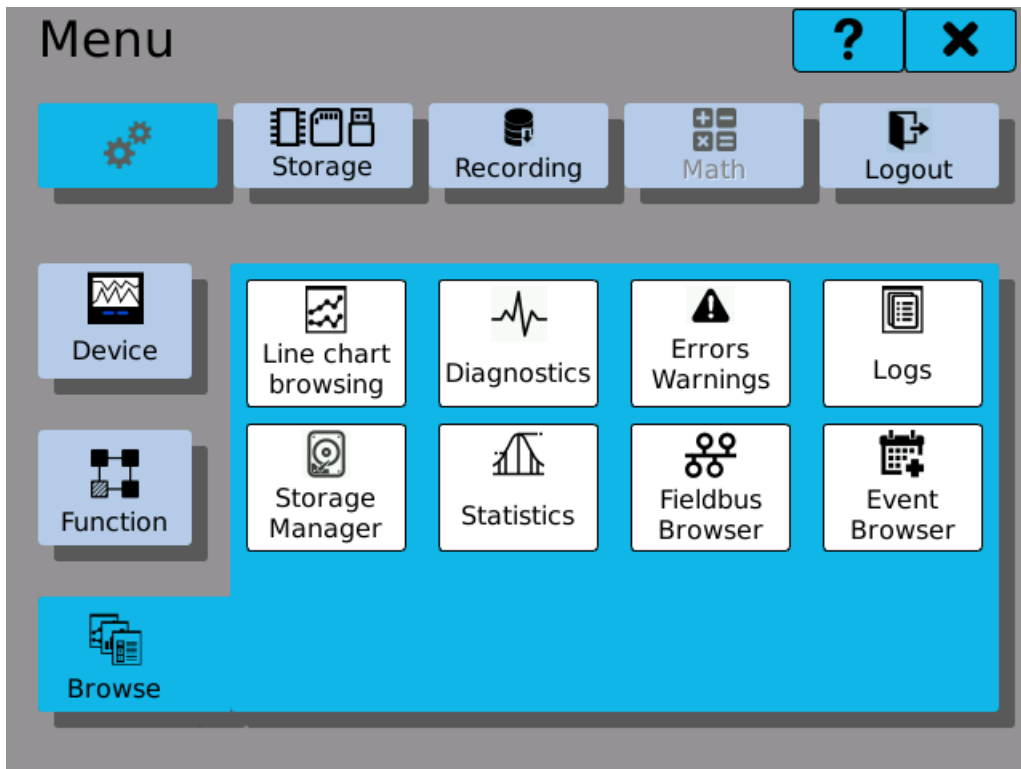

Browse Menu

5

Input and data processing

5 Input and data processing

This menu contains configuration of inputs, outputs, data processing (nodes) and other associated components.



I/O card settings.



Timers settings.



Constants settings.



Node settings.



Fieldbus configuration.

5.1 Input and output cards

Each of the I/O cards has at least one channel, which itself performs some recalculations.

The following parameters can be edited in the settings:

Position

Position of the card that we want to set. Buttons ◀ ▶ serve for rolling among the plugged-in cards (e.g. if there is no plugged-in card on position 3, the setting will not offer it).

Type

Type of the card that is present on a selected position.

Priority

Card data transfer priority.

In case of higher number of connected I/O cards, the data transfer rates can drop. By adjusting priorities you can achieve adequate transfer rates for all inputs.

HIGH - the card will transfer every packet (1100 or 550 packets/s)

MEDIUM - the card will transfer every other packet (550 or 275 packets/s)

LOW - the card will transfer every fifth packet (220 or 110 packets/s)

Channel number

Number of the channel that we want to set. Buttons ◀◀ ▶▶ serve for rolling among the channels. The number of possible adjustable channels is determined by the card, which we set.

The button  is used to navigate to the settings of the selected channel.

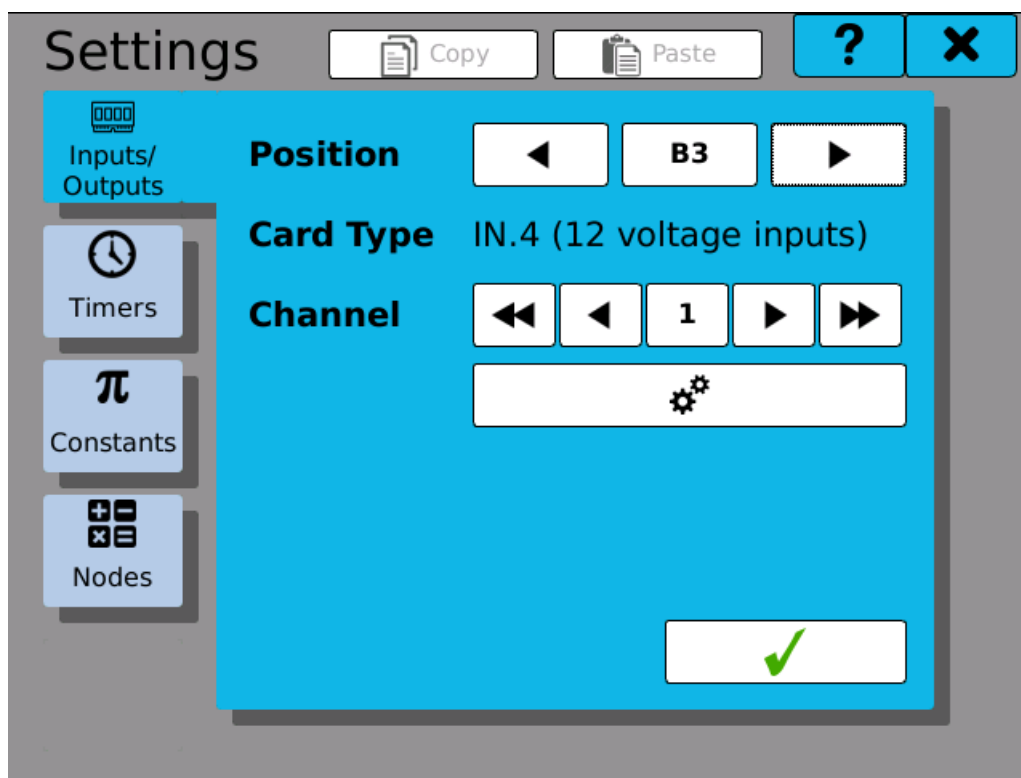

Channel setting

5.1.1 Channel settings

In the input and output settings you will find a summary of all setting parameters, which may be performed on the respective card and on the respective input or output. These are e.g. the range, filter and filter constants settings, measurement rate, minimum and maximum limit value, tare and many others.

Setting of individual cards is described in the next chapters.



Parameter	Value
Range	0 .. 10V
Filter selection	No filter
Filter constant	0.0000
Minimum physical value	0.0000
Maximum physical value	10.00
Tare	0.0000

IN 12 card setting (voltage card)

5.2 Timers

Timers provide a periodic execution of various tasks of the recorder.
The following parameters are edited in the settings:

- Timer** Number of the currently viewed or edited timer. Up to eight timers can be configured.
- Name** Name of the timer. Under this name you will see the timer in the next settings of the device. The name can consist of up to 32 characters.
- Unit** Unit value reported in the Period.
- Period** Time, after which the timer related operations repeat.

Using buttons  **Copy** and  **Paste** you can copy complete settings among the channels.

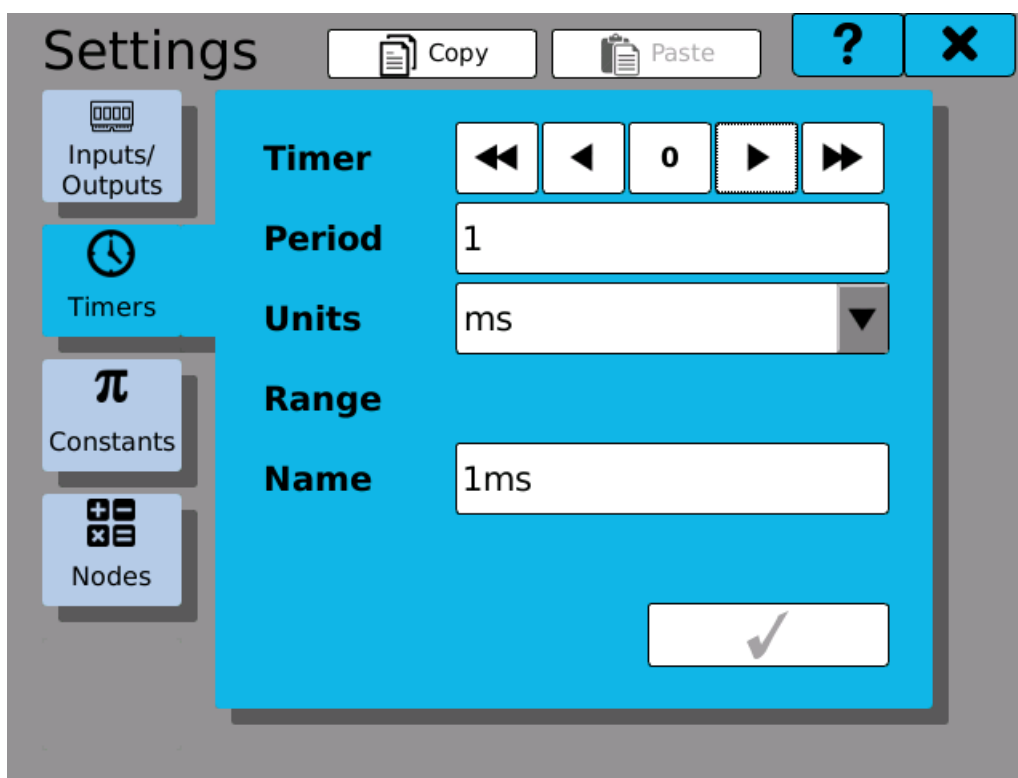

Timer setting

5.3 Constants

Constants are spontaneously unchangeable named values for further use. The following parameters are edited in the settings:

- Constant** Number of the currently viewed or edited constant. Up to 64 constants can be defined.
- Name** Name of the constant. Under this name you will see the constant in the next settings of the device. The name can consist of up to 32 characters.
- Type** Type of the constant. Mathematical type indicates the number with a decimal point. Logical type indicates state 0 (false) or 1 (true).
- Value** Value of the constant. In case of the mathematical type, it relates to a numerical value, in case of the logical one, you can enter 0 (false) or 1 (true).

Using buttons  **Copy** and  **Paste** you can copy complete settings among the constants.

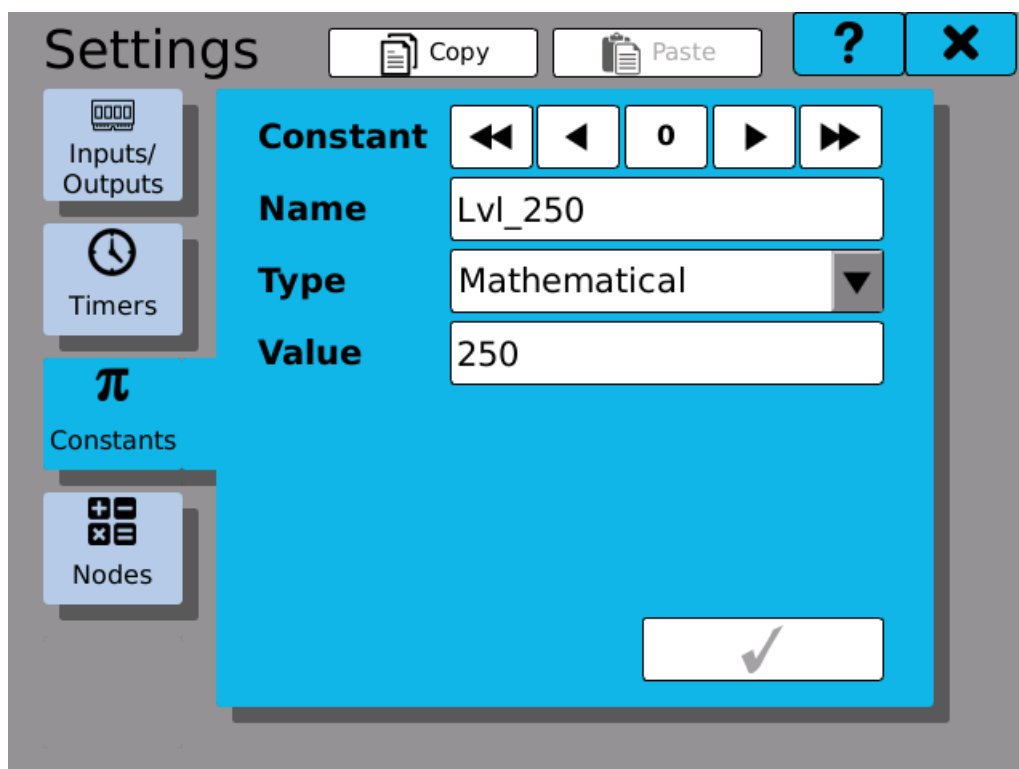

Setting named constants

5.4 Nodes

Nodes are an integral part of the device's function. Node is an object which reads value from the selected input or inputs, can perform various operations with the data periodically and holds the result. The resulting value can then be displayed, used as an input for another node(s), recorded, etc.

Nodes are configured by following parameters:

Node	Number of the currently edited node. Up to 256 nodes can be configured.
Name	Name of the node. Can be up to 32 characters long. While it does not have to be unique, it is advisable to use unique and sensible names.
Unit	Determines the unit, which will be associated with value of the node. It is possible to choose from units of voltage, current, pressure, etc.
Timer	Period of the selected timer decides how often the node reads its inputs and performs calculations.
History	Sets the count of previous values, that are held in the memory. This short term value history is used for statistical calculations, drawing graphs, etc. Values are not persistent and will be lost when the device shuts down.
Function	Specifies the function that the node will perform. Functions are: <u>Not used</u> - The node does not process data and is invalid. <u>Math</u> - Arithmetical operations using predefined formulas. <u>Logic</u> - Logical operations using predefined formulas and flip-flops. <u>IO buffer</u> - Reading data from I/O card input. <u>Comparator</u> - Comparison of two values. <u>Generator</u> - Configurable function generator.

Further function setups and specifications of input and output values can be managed when using the button  next to the selection.

Output Limits A click on the setting button  takes you to the dialog for setting limits and outputs of the current node.

Value Current value of the node.

Using buttons  **Copy** and  **Paste** you can copy complete settings among the nodes.

Settings Copy Paste ? X

Inputs/Outputs

Timers

Constants

Nodes

Node ◀◀ ◀ 1 ▶ ▶▶

Name Voltage

Unit mV ⚙️

Alias V (max. 4 chars)

Timer 100ms ▼

History 1000

Function IO buffer ▼ ⚙️

Outputs Limits ⚙️

0 ✓



Node configuration

5.4.1 Generator

It is used to generate signals sinus, saw, triangle, rectangle, or a random course. The following parameters are edited in the generator settings:

- Type** Clicking on the button displays a choice of six types. The types are rising saw, declining saw, triangular waveform, rectangular waveform, sinus function graph and random data.
- Minimum** Minimum function range.
- Maximum** Maximum function range.
- Period** Time to replay the function. Period can be set only for the functions that require it.
- Duty cycle** The percentage signal ratio between the length of the front and rear edges, or if the signal is in its maximum or minimum. The specified percentage always indicates the length of each front edge or the length of the maximum value (e.g. if we have 20% - 20% of the period is in maximum and 80% of the period is in minimum). Duty cycle can be set only for the functions that require it.

Available generator functions:

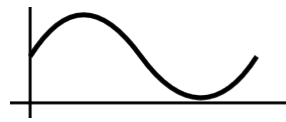
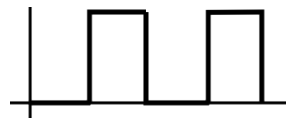
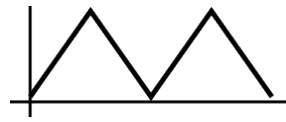
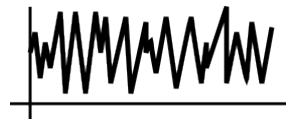
	Declining saw. Adjustable: minimum, maximum and period.
	Rising saw. Adjustable: minimum, maximum and period.
	Sine. Adjustable: minimum, maximum and period.
	Rectangle. Adjustable: minimum, maximum, period and duty cycle.
	Triangle. Adjustable: minimum, maximum, period and duty cycle.
	Random signal. Adjustable: minimum and maximum.

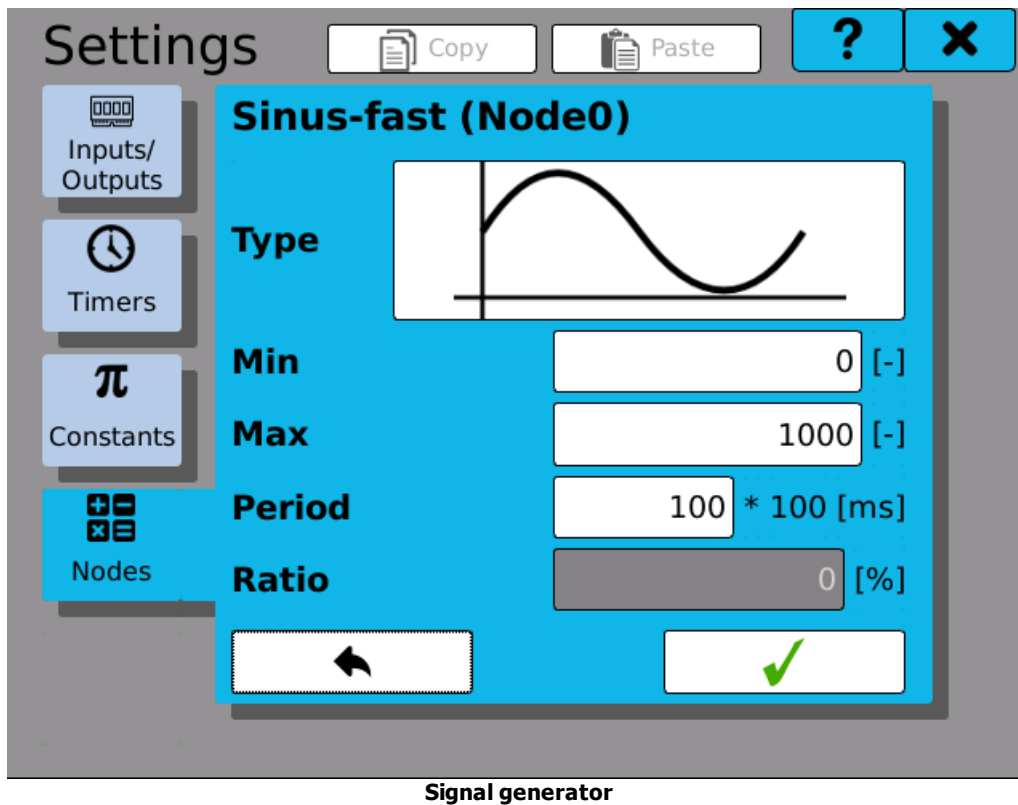

5.4.2 Comparator

Compares two or more parameters among themselves and on the basis of the comparison result it sets the value of the node on 1 (truth) or 0 (untruth). The following parameters are edited in the comparator settings:

f(x) Function used for comparison. The name matches the order of calculation and parameters. For example: Entering (1) >= (2) means that we compare whether parameter 1 is bigger than or equals parameter 2.

(1),(2) ...
(7),(8) Parameters of the comparator.

On the line of the comparator parameter there is the name of the node used, of the input, output, named constant or numeric value. If no value is assigned to the parameter, inscription "**Not used**" appears on its line.

Clicking on the parameter line opens a window for parameter selection (see chapter "**Parameter selection window**"), where you can add, change or remove the parameter value.

Settings Copy Paste ? X

Sum 250 (Node2)

f(x) (1) \geq (2) ▼

(1) Sinus-fast (Node0)

(2) 50.00

(3) Not used

(4) Not used

(5) Not used

(6) Not used

(7) Not used

(8) Not used

↩ ✓

Inputs/Outputs

Timers

Constants

Nodes

Comparator settings

5.4.3 IO buffer

It is used mainly for displaying the measured values on the screen. It stores the input or output data into memory and when a running chart is displayed, we can also see their throughout history. The storage capacity is determined by the entry in the setup of the **History** node. Storage data do not serve as a record and therefore no backup is available. If the recorder is switched-off or switched-on, the storage data will be lost.

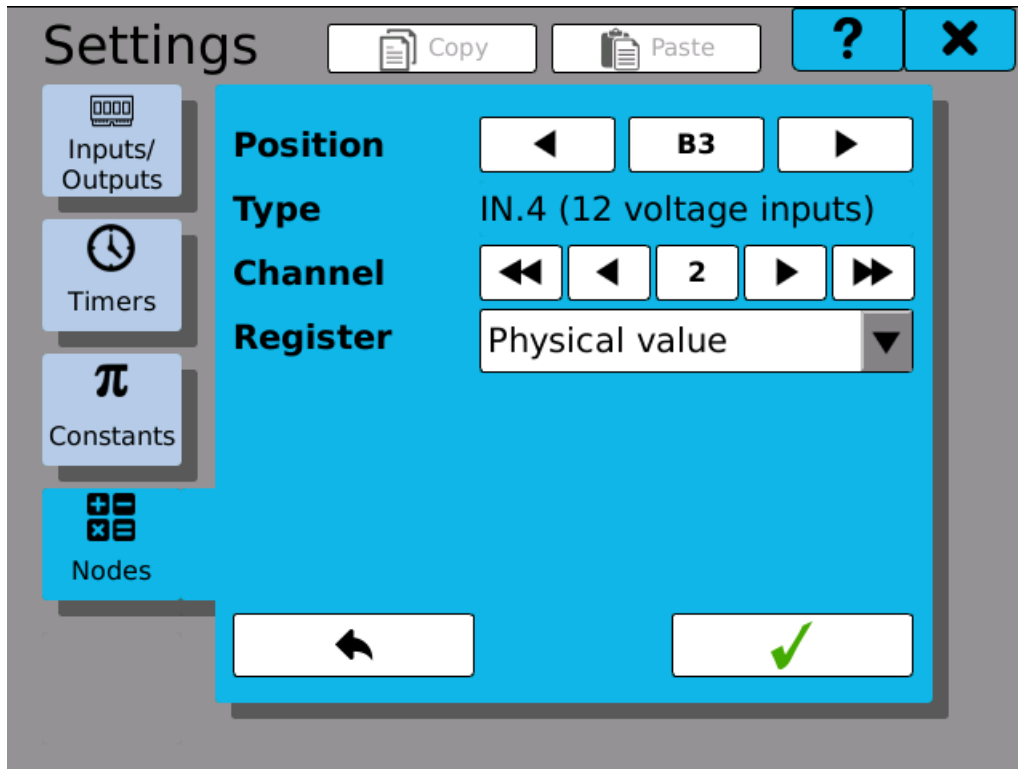

IO buffer setting

5.4.4 Logical functions

Logical functions perform logical operations or act as flip-flops using selected inputs.

The following parameters are edited in the settings:

f(x) The operation used for calculations. The name matches the order of calculation and parameters. For example: Entering (1) + (2) means that parameter 2 should be added to parameter 1.

(1),(2)...
(7),(8) Parameters of the selected function.

Operator notation:

! Negation
+ Logical OR
· Logical AND
⊕ Logical XOR

Flip-flops:

RS Reset-set (The "R" input has a priority).
SR Set-reset (The "S" input has a priority).

Different operations and flip-flops can allow different number of inputs. The available parameter boxes are white, unavailable are grayed-out. In order to assign the input, click on the parameter box next to the index number and select the input you want to use. Inputs are selected using the "**Parameter selection window**". It is possible to leave some inputs unused.

SR (Node 8)

f(x)	SR (S=(1), R=(2)) ▼
(1)	Gen1 (Node 6)
(2)	Gen2 (Node 7)
(3)	Not used
(4)	Not used
(5)	Not used
(6)	Not used
(7)	Not used
(8)	Not used

Logical function settings - SR flip-flop

5.4.5 Mathematical functions

Mathematical functions perform arithmetical operations on values from selected inputs using predefined formulas.

The following parameters are edited in the settings:

f(x) Function used for calculations. The name matches the order of calculation and parameters. For example: Entering (1) + (2) means that parameter 2 should be added to parameter 1.

(1),(2)...
(7),(8) Parameters of the selected function.

Different functions can allow different number of inputs. The available parameter boxes are white, unavailable are grayed-out. In order to assign the input, click on the parameter box next to the index number and select the input you want to use. Inputs are selected using the "**Parameter selection window**". It is possible to leave some inputs unused.

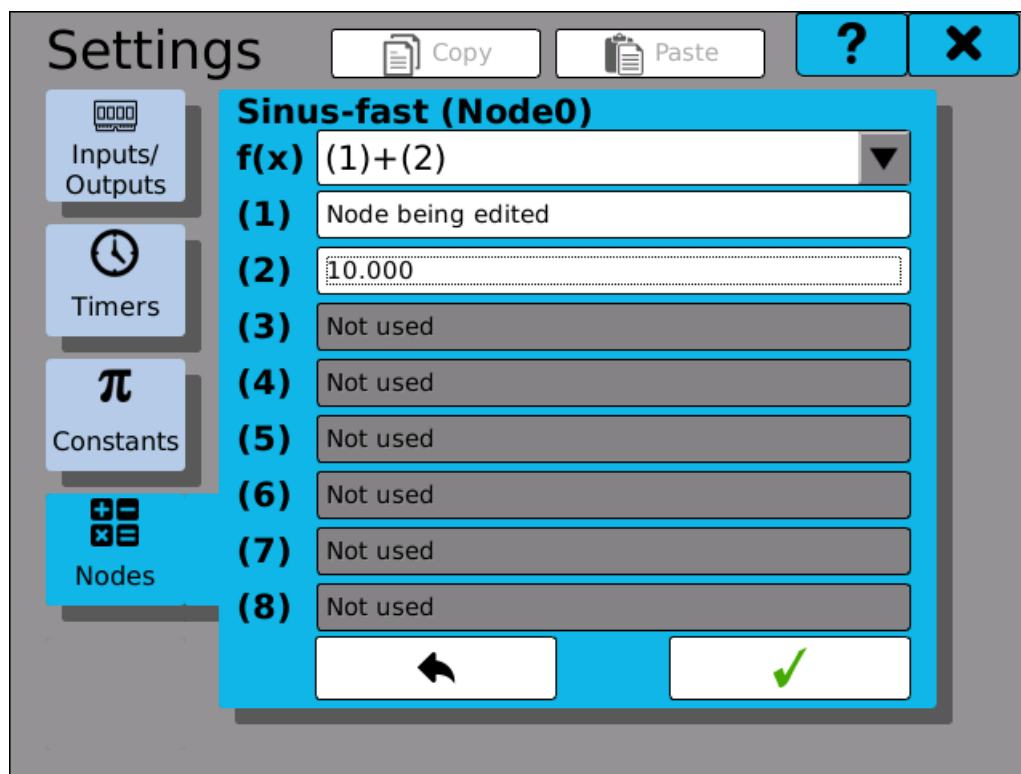

Mathematical function settings

5.4.6 Limits and Outputs

By clicking on the tab you can switch between setting limits and setting outputs. The following parameters are set in the limits settings:

- Minimum** Clicking and ticking the square authorizes the lower limit. Limits of the lower limit can be set by clicking on the value line.
- Maximum** Clicking and ticking the square authorizes the upper limit. Limits of the upper limit can be set by clicking on the value line.
- Saturate** If at least one of the limits is permitted, we can authorize or prohibit saturation (cutting down to minimum or maximum).
- Underflow limits** We select in the table what should happen in case of underflow of the lower limit. The options are: Nothing, Warning, Error or Critical error.
- Overflow limits** We select in the table what should happen in case of overflow of the upper limit. The options are: Nothing, Warning, Error or Critical error.

In the output settings we connect e.g. relay outputs on the cards, analogue outputs or logical outputs. Clicking on the authorized line opens the parameter selection window, in which we find and connect the desired output to the edited node.

Sinus-fast (Node0) ? X

Limits Outputs

Minimum: 10

Maximum: 50

When limit underflows

Nothing

Warning

Error

Critical error

When limit overflows

Nothing

Warning

Error

Critical error

Saturate: No Yes

Limits

TRI_1s (Uzel1) ? ×

Limits **Outputs**

(1)	<input type="text" value="/O 3/26"/>
(2)	Not used
(3)	Not used
(4)	Not used
(5)	Not used
(6)	Not used
(7)	Not used
(8)	Not used

Outputs

5.5 Fieldbuses

Fieldbus module can be used to transfer data remotely using protocols such as Modbus. The device can use several different fieldbuses at once. The data transfer is possible both ways, eg. both read and write access is available, if configured appropriately. This way it is possible to access current measured data from a remote device or for example trigger custom defined actions remotely using the Events module.

Fieldbus configuration varies depending on selected type. For example if you set the fieldbus to work as a Modbus TCP Slave, an option to set the IP port becomes accessible.

Each fieldbus can have several cells configured. A cell represents a value with defined name and several other properties depending on selected fieldbus type.

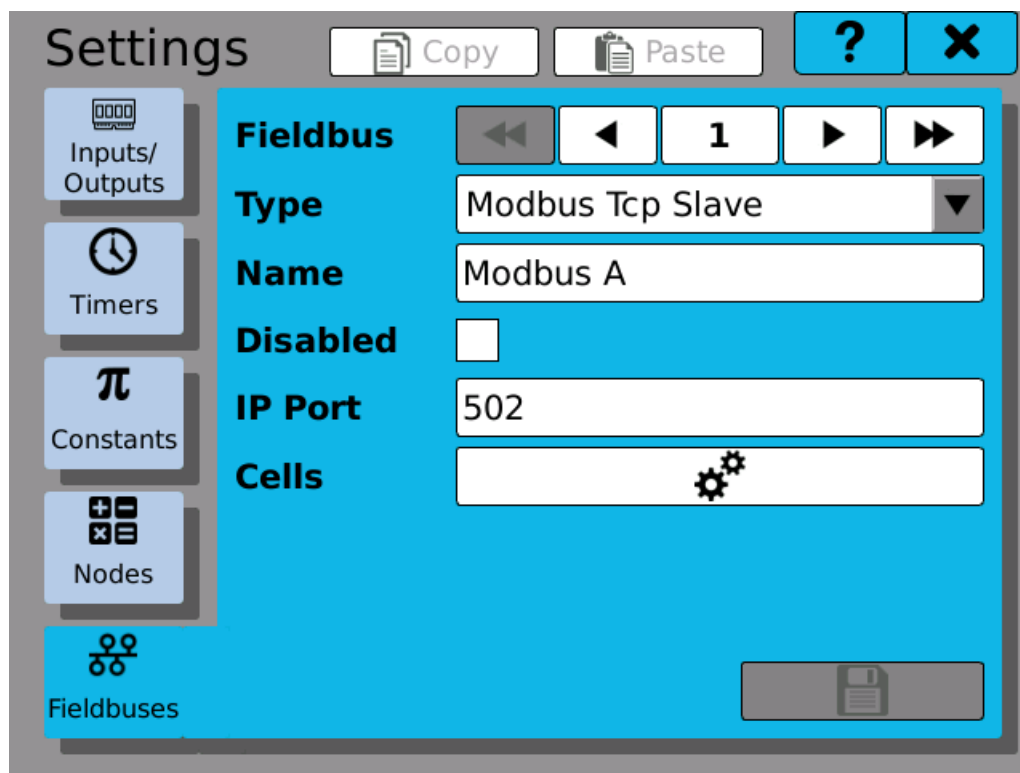

Fieldbus configuration window

5.5.1 Modbus TCP Slave

Fieldbus configured as a Modbus TCP Slave can communicate with any standards-compliant device acting as a Modbus TCP Master. There can be only one Modbus TCP Slave fieldbus configured at a time.

Modbus "Modbus A" -> Cells

Cell: 1

Name: Voltage meas.

Disabled:

Value type: Mathematical

Access: Input register

Start Address: 1234

Used Addresses: 1234, 1235

Fieldbus cell settings (Modbus TCP Slave cell)

Fieldbus cell settings (Modbus TCP Slave cell)

- Cell** Cell index.
- Name** User defined cell name.
- Disabled** If checked, this cell is ignored. This option is intended to temporarily disable remote access.
- Value type** Logical - stores binary value (0 - false or 1 - true)
Mathematical - stores floating decimal point number (uses two registers)
Counter - stores 32-bit unsigned number (uses two registers)
- Access** Options vary depending on selected Value type.
Logical - Discrete input or Coil
Mathematical, Counter - Input register or Holding register
 Inputs serve solely for remote read access, Coils and Holding registers can be used for both read and write access.
- Start Address** Address of the first register that will be used for data exchange. If necessary, following addresses can be used automatically as well.
- Used Addresses** Calculated used address(es).

5.5.2 Fieldbus browser

You can use Fieldbus browser for reviewing Fieldbus module configuration and diagnostics. It can be found in the Main menu -> Browse tab. It lists all the configured fieldbuses and their cells.

Each cell shows it's name, current value and short information about type.

Modbus Short for cell access type and used address(es)

TCP

DI Discrete Input

CO Coil

IR Input Register

HR Holding Register

	Name	Value	Info
1	<input checked="" type="radio"/> Voltage meas.	3.730	IR 1234, 1235
2	<input type="radio"/>		
3	<input type="radio"/>		
4	<input type="radio"/>		
5	<input type="radio"/>		
6	<input type="radio"/>		
7	<input type="radio"/>		
8	<input type="radio"/>		
9	<input type="radio"/>		
10	<input type="radio"/>		
11	<input type="radio"/>		
12	<input type="radio"/>		

Fieldbus browser

6 Output and graphics

Outputs and graphics dialogue allows configuration of following modules:



Groups settings. Manages groups of nodes for easier manipulation.



Screens settings. Manages screens with meters that display measured values.



Records settings. Determines what values and how are being recorded.



Events settings. User-configurable actions based on defined conditions.

6.1 Groups

It serves to simplify the settings by grouping signals from the card channels, nodes or outputs (both relay and analogue), and it also simplifies their subsequent preset, which can be further used to create screens or records.

Group	Number of the currently viewed or edited group. Up to 16 groups can be configured.
Name	Name of the group. Under this name you will see the group in the next settings of the device. The name can consist of up to 32 characters.
Items	Number of assigned values in the group. The button  opens management of the items in the group, where you can edit, add or delete them.

Using buttons  **Copy** and  **Paste** you can copy complete settings among the groups.

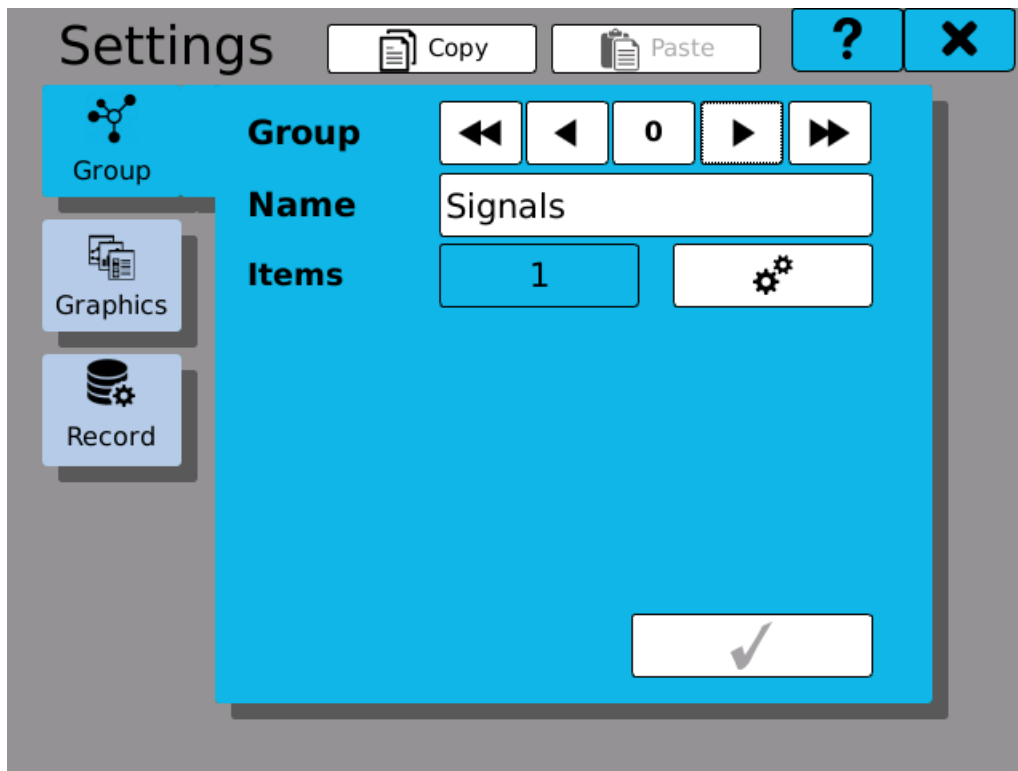

Setting groups

6.1.1 Adding items into group

There is a list of 16 buttons in the window for adding parameters and for their management. The logic of adding and deleting parameters is as follows:

Adding parameters: From top to bottom by clicking the button **"Add new parameter"** (parameter is added and the next button is released).

Deleting parameters: From bottom to top by clicking the last button with a parameter, and by selecting the option **"Not used"** in the parameter selection window (see chapter **"Parameter selection window"**).

Clicking the button **"Add new parameter"** or a **line with an item** opens the window with a selection of colors and with settings of the range.

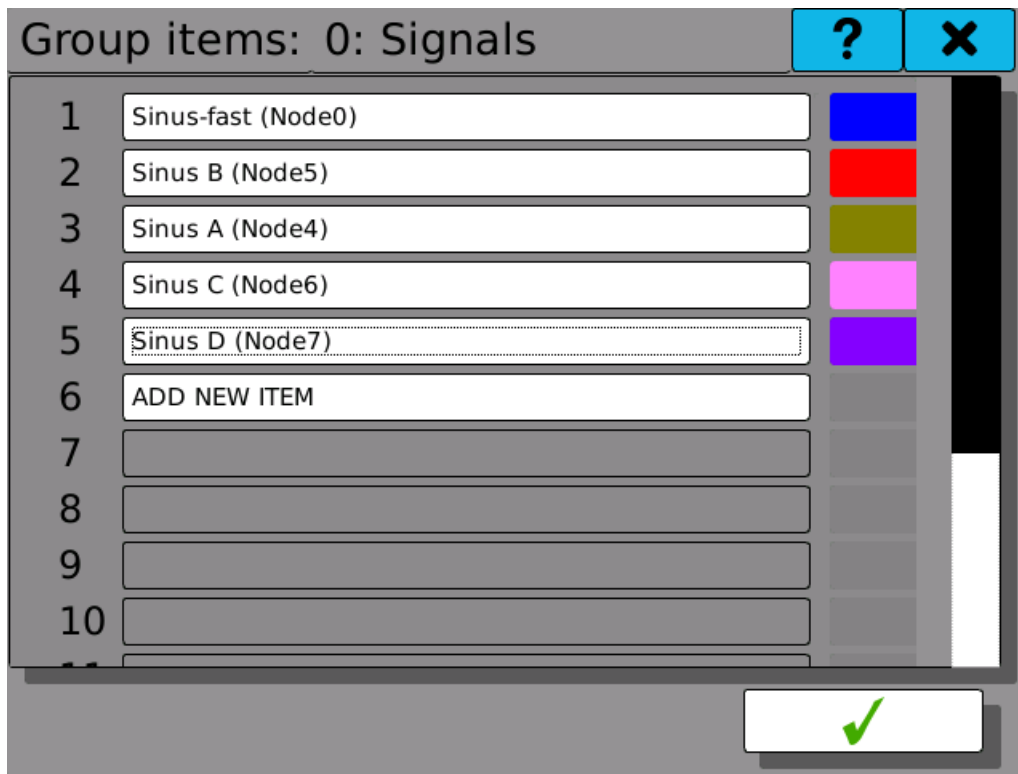

Selecting items

6.1.2 Item Editing

Selection of the item is done in the window for editing and parameter selection. Click on the white line opens item selection dialogue, where we select the item. The color is chosen by clicking on the colored box with a selection of colors from a color palette.

There are 3 options for the selection of display and of a limit minimum and maximum: **"Disable"** means that it is not possible to use the display range from the group. **"Enable"** means that values entered in the lines can be used in other settings from the group. **"Inherited"** means that values entered in the item can be used in other settings from the group.

For the minimum, maximum and average values we specify, whether the values should be displayed on a graphical element or not.

Explanation:

Disable means that there is no preset parameter in the group and that the setup of this item from the group cannot be used for further settings of the graphic elements.

Enable means that there is a preset parameter in the group and that the setup of this item from the group can be used for further settings of the graphic elements.

Inherited means that parameter gets its value from the previous setup of the node, input and constant. This is selected in the line "Item".

Display minimum and maximum specify display limits that may be used in setting the graphic elements as a display range of the element.

Limit minimum and maximum specify limits of the limit that may be used in setting the graphic elements. It will be displayed as a part of the color-coded graphical element. Limit minimum must be bigger than the display minimum and limit maximum must be smaller than the display maximum.

Minimum, maximum and average value specify the symptom of a graphic element that determines whether the reached minimum, maximum and average value should be displayed.

Group item: 0 [?] [X]

Item: Sinus-fast (Node0) [Blue Box]

Display minimum: Enable [v] 0.0000

Display maximum: Enable [v] 100.00

Limit minimum: Enable [v] 20.00

Limit maximum: Enable [v] 20.00

Value minimum: Disable [v]

Value maximum: Disable [v]

Value average: Disable [v] [Green Checkmark]

Item editing

6.2 Screens

Setting graphic display of the measured values.
The following parameters can be edited in the settings:

- Screen** Number of the currently edited screen. Up to 16 screens can be configured.
- Name** Giving name to the screen. Under this name you will see the screen in the next device settings. The name can consist of up to 32 characters.
- Group** Selection of one of the preset parameter groups. If there is one preset element on the screen (from or without the group), the selection cannot be changed. To be able to change it, you have to erase settings of all the graphic elements of the screen.
- Arrangement** Selection of a grid for the arrangement of graphic elements. Standard arrangement is 4x4. Another options are 5x5, 3x4 a 4x3.

Using button  you get to settings and arrangement of graphic elements on the screen.

Under the grid there is a graphical preview of the screen and of the elements arranged in the screen. If there is any vacant part in the graphical preview of the screen, it is filled in by the symbol .

Using buttons  **Copy** and  **Paste** you can copy complete settings among the screens.

Button  **Erase** serves for erasure of all graphic elements of the screen.

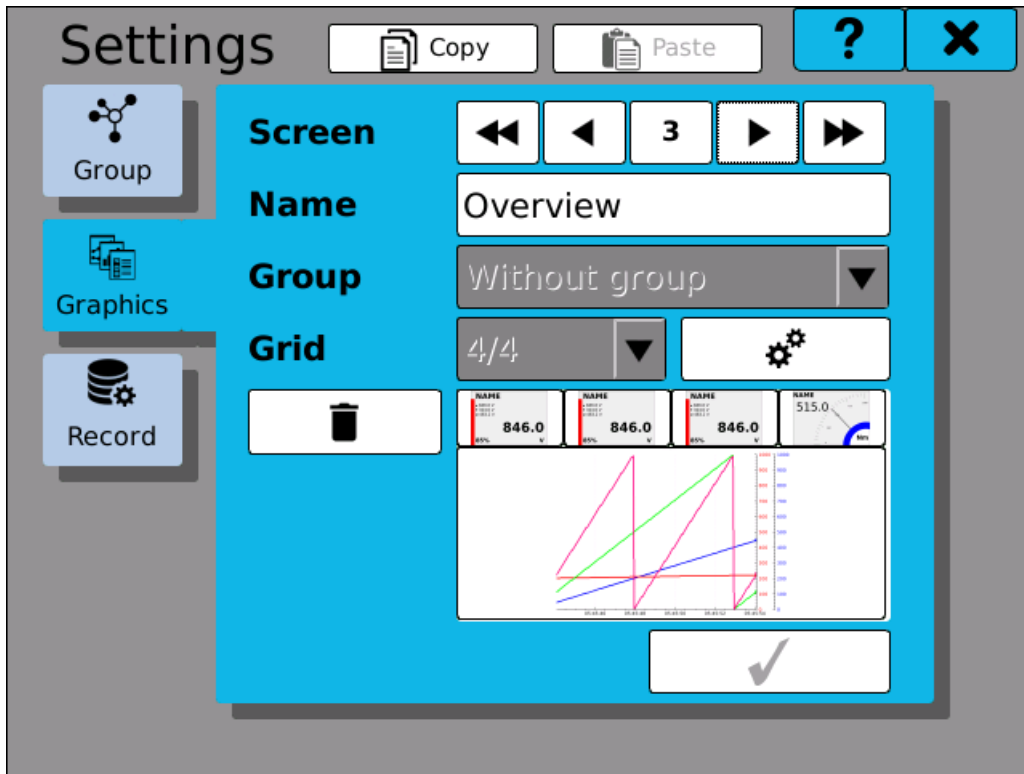

Screen settings

6.2.1 Graphics configuration

It is used for a practical configuration of the various visual elements on the screen.

In this configuration we see a grid of green rectangles. Into each of the rectangles you can insert one element. You can choose more than one rectangle at a time and the display element takes the size of the marked field. You can select the rectangle by clicking on one of them (upper left corner of the element) and it will turn red. Any other click on each rectangle **under or to the right** from the selected one (lower right corner of the element) will select the area of the display element with red color.

After selection of the desired area, clicking the button  takes you to the screen for setting the display element, its style and parameters.

Upon completion of setting styles and parameters of the display element, the selected area will change into the image of this element. By clicking on the icon you can edit or erase the respective element. If there is space on the screen, you can add another element by selecting again the rectangle area and by clicking the button.

Setting of the graphic elements on the screen is saved by the button .

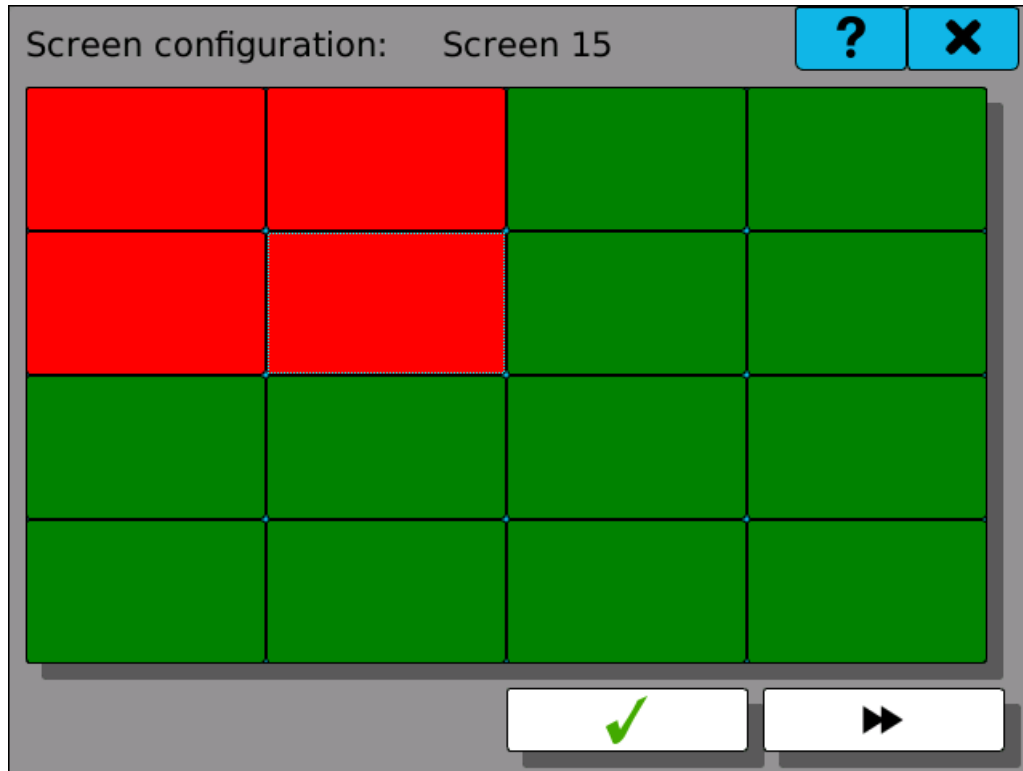

Area selection for the display element

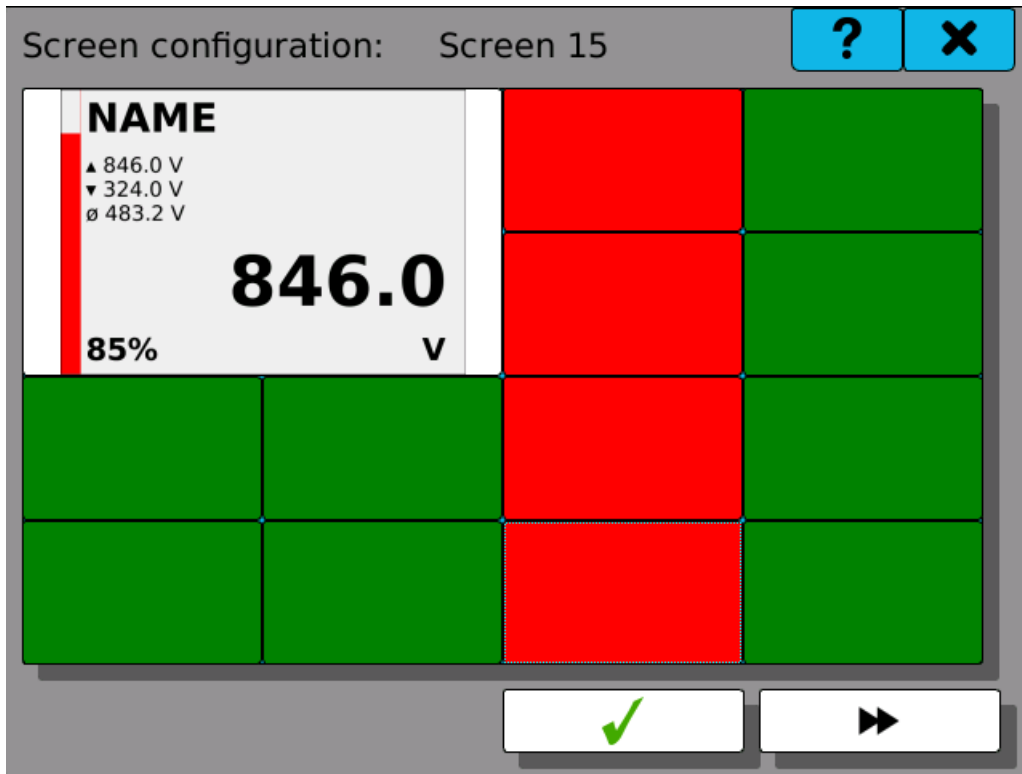

6.2.2 Setting style and parameters

It is used for setting the appearance of the graphic item and the quantity, which it displays.

The following parameters can be edited in the style and parameter settings:

Type Clicking on the button displays a choice of six types of display elements.

The button  takes you to the advanced options that are specific for each display element.

Value Range The range of values visible on the display element.

Parameters One to four parameters displayed on the display element. Clicking on the line takes you to the parameter selection window (see chapter "**Parameter selection window**" and "**Selecting items from the group**"). By clicking on the colored rectangle next to the parameter line you can choose the color of the parameter.

Types of display elements:

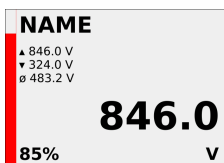

Numeric display with bargraph. Percentage figure indicates the input value in proportion to the given range. There is a possibility of displaying minimum, maximum and average of the measured values.

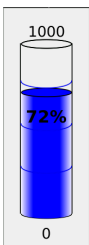

Bar chart indicating minimum and maximum value range and the percentage displayed in the element.

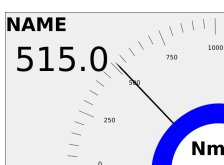

Pointer measuring instrument with numeric values.

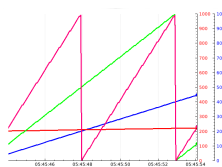

Running chart with the X axis as a time axis (horizontal). Up to four parameters simultaneously.

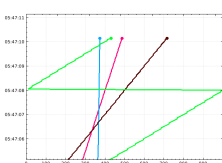

Running chart with the Y axis as a time axis (vertical). Up to four parameters simultaneously.



IP camera (not yet available)









No style selected.

Style and parameters Item: 0

Type

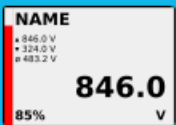
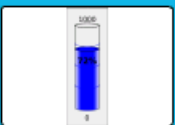
Value range

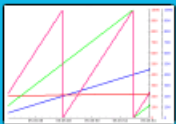
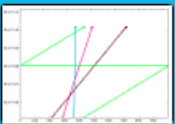
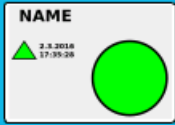

Parameters:

Style selection



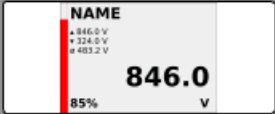

Style and parameters Item: 0

Type  

Value range

Parameters:

<input type="text" value="Sinus-fast (Node0)"/>	
<input type="text"/>	<input type="text"/>
<input type="text"/>	<input type="text"/>
<input type="text"/>	<input type="text"/>



Adding parameter and color

6.3 Records

They determine what, when, how and where should be recorded. There is a possibility of setting recorded value from measured or calculated values, of determining period of recording in compliance with the timers, selecting format of the output file and a memory media to be recorded in.

The following parameters are edited in the records settings:

Record	Number of the currently viewed or edited record. Up to 16 records can be configured.
Name	Name of the record. Under this name you will see the record in the next settings of the device. The name can consist of up to 32 characters.
File name	Name of the file, which has a fixed beginning in the form of RECXX_YYYYY, where XX is the number of the record. Thus from 00 to 15 and YYYYY makes the serial number of the file. Sequential file number increases by one each time when the number of records in one file reaches the value specified in the "Entries in the file", or if you interrupt recording and start it again.
File type	Supported types of stored files are: Binary files or CSV. It is not possible to store CSV formatted files into internal memory.
Timer	Selection from all defined timers. It determines with what period the values will be recorded.
Memory	Memory medium, on which the logs will be recorded. USB, SD card or internal memory of the recorder. Internal memory cannot be used to store records in CSV format.
Records in the file	Maximum number of values recorded into one file. Exceeding this value will create a new file.
Group	Selection of the set group of measured or calculated values that will be recorded. If the group is selected, the record should be pre-filled by all items in the group. The button  opens administration of the items stored under the given record.

Using buttons  **Copy** and  **Paste** you can copy complete settings among the records.

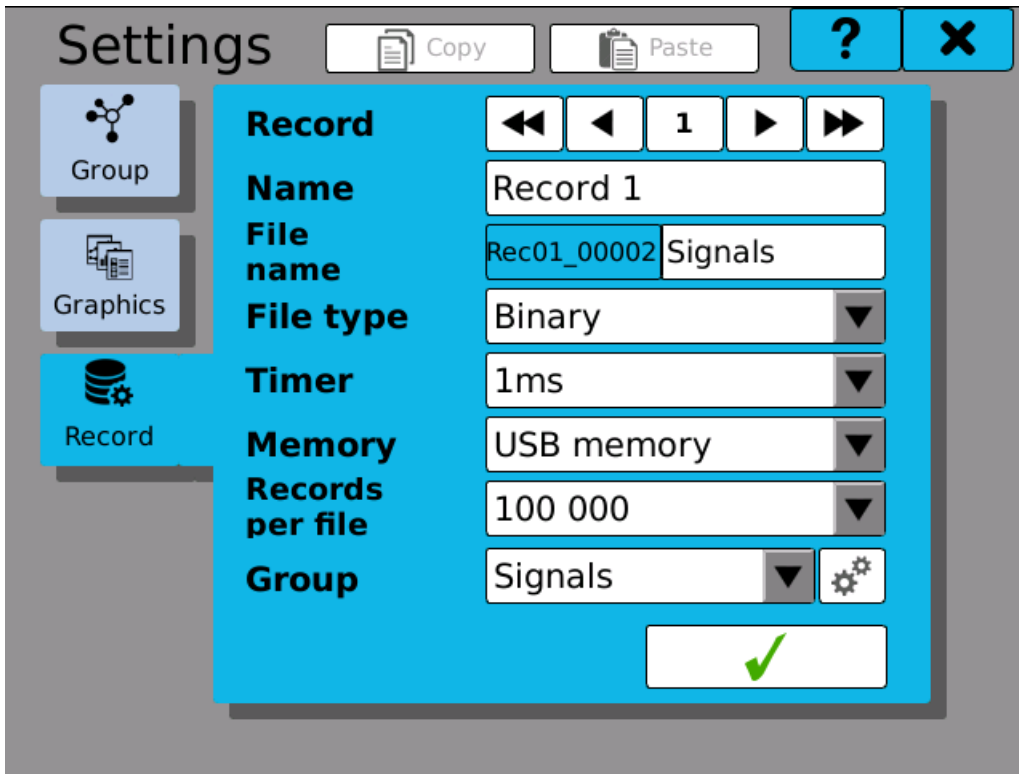

Setting records

6.3.1 Adding parameters

There is a list of 16 buttons in the adding parameters window. The logic of adding and deleting parameters is as follows:

Adding parameters: From top to bottom by clicking the button **"Add new parameter"** (parameter is added and the next button is made accessible).

Deleting parameters: From bottom to top by clicking the last button with a parameter, and by selecting the option **"Not used"** in the parameter selection window (see chapter **"Parameter selection window"**).

If a group is used, by ticking the button  we can move to the group item selection.

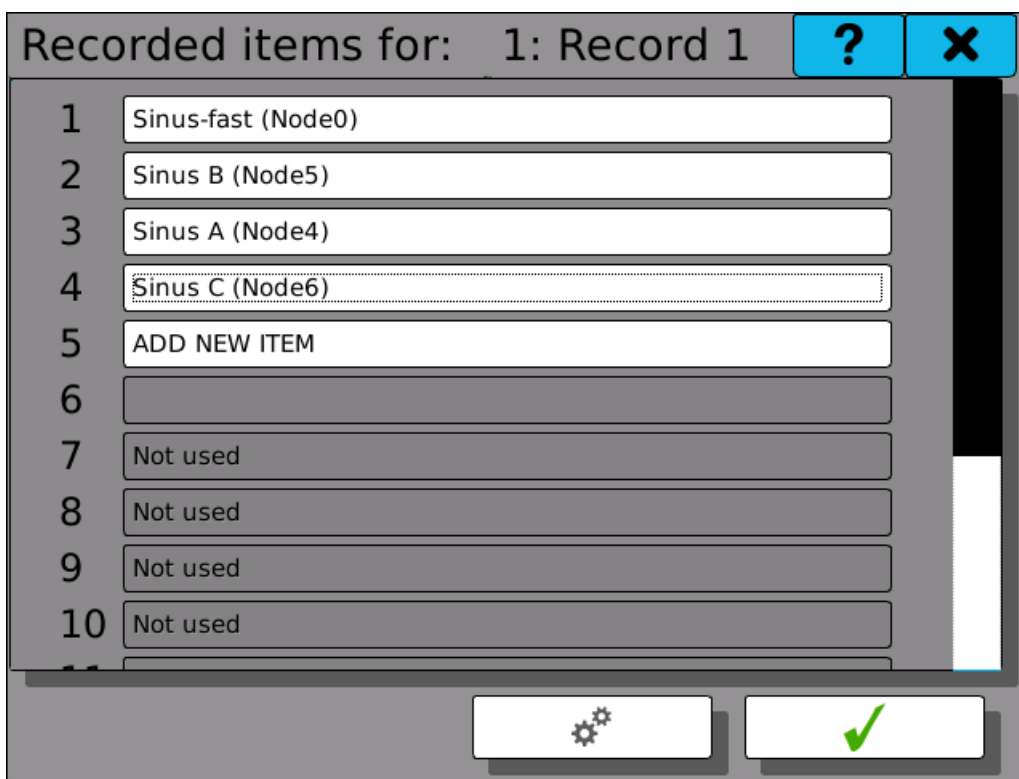

Selecting items outside the group

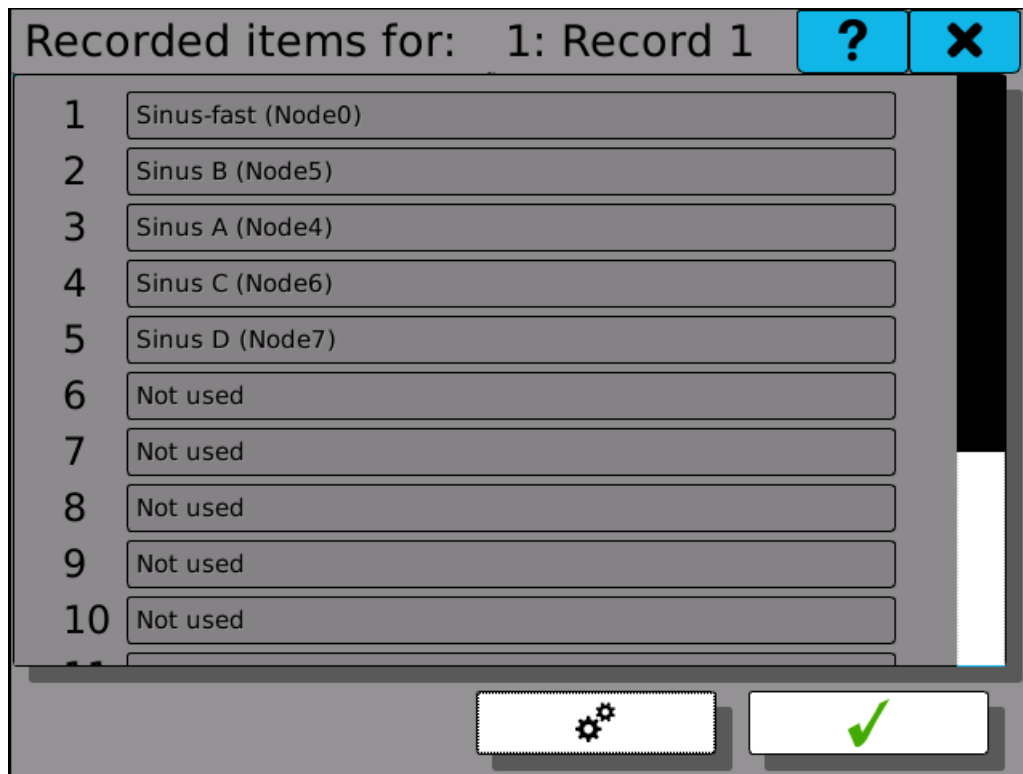

Selecting items from the group

6.4 Events

Event module allows the device to trigger custom-defined actions when specific conditions occur. The usual use-case is triggering recording remotely or controlling outputs based on system condition.

Event take place at a specific moment in time when any of the conditions (called "causes") is met. It has no duration nor holds any value. Once an event occurs, it triggers all its effects.

Event	Index of currently configured event. Up to 16 events can be configured.
Name	User-defined name.
Disabled	Once checked, this event is ignored and cannot take place even if conditions are met.
Causes	Conditions, which can cause this event to take place.
Effects	Effects, that are triggered once the event takes place.

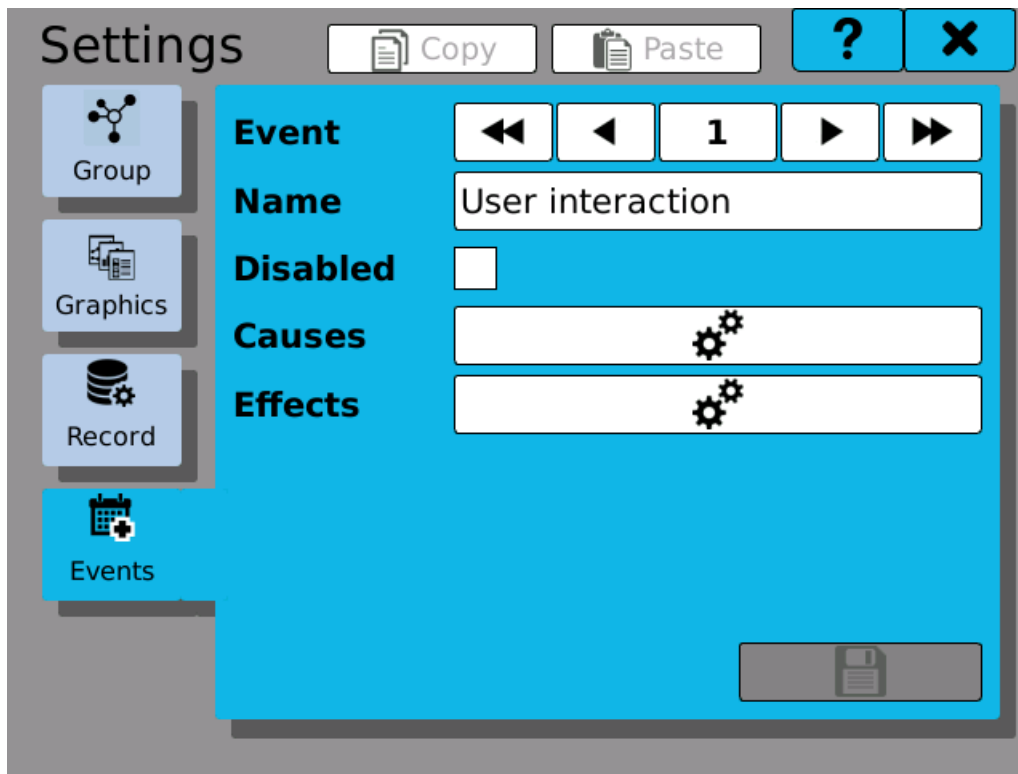

Event configuration

6.4.1 Causes

Every event can have several causes configured. Note that meeting the conditions of any of configured causes is sufficient.

Following types of causes are available:

- Button** Buttons at the front side of the device can be configured for use as a trigger. There are three actions, that can be selected: pressed, released and clicked. Actions "pressed" and "released" react on simple button press or release without any additional conditions. Action "clicked" is triggered when the button is pressed and then released in a short period of time.
- Node** Change of state of a node with logical value.
- System condition** Transition to system condition. This cause does not take into consideration which state the device has been in before the transition happened, only current state. For further details about system states, read chapter Control Bar
- Fieldbus** Change of state of a logical-type fieldbus cell.

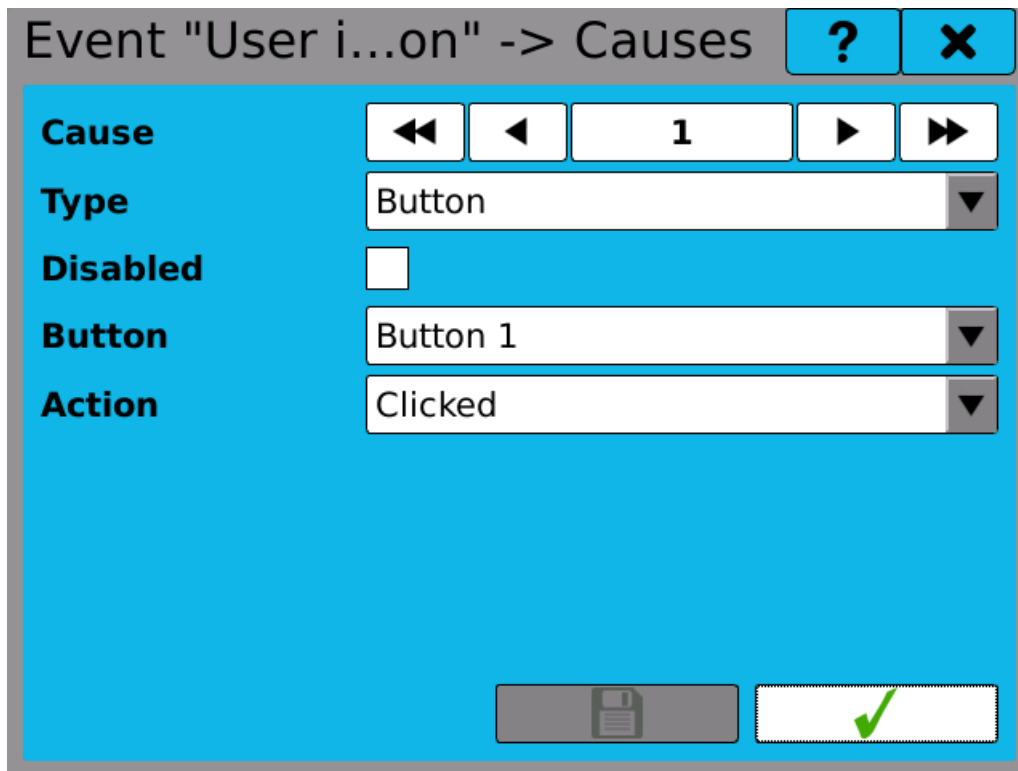

The screenshot shows a configuration window titled "Event 'User i...on' -> Causes". The window has a blue background and a grey border. At the top right, there are two buttons: a question mark and a close 'X'. Below the title bar, there are five controls: a double left arrow, a single left arrow, a text box containing the number '1', a single right arrow, and a double right arrow. Below these are four dropdown menus: "Type" (set to "Button"), "Disabled" (with an unchecked checkbox), "Button" (set to "Button 1"), and "Action" (set to "Clicked"). At the bottom of the window, there are two buttons: a grey button with a floppy disk icon and a white button with a green checkmark icon.

Cause configuration (type "Button")

6.4.2 Effects

When the event takes place, a number of different effects (actions) can be triggered as an effect. Each event can have up to four different effects. Note that all the effects are triggered at the same time.

There are several types of effects.

Record Starts, stops or toggles recording.

Set I/O Sets output register to a selected value. The value can be either logical or mathematical. This effect can typically be used to switch a relay.

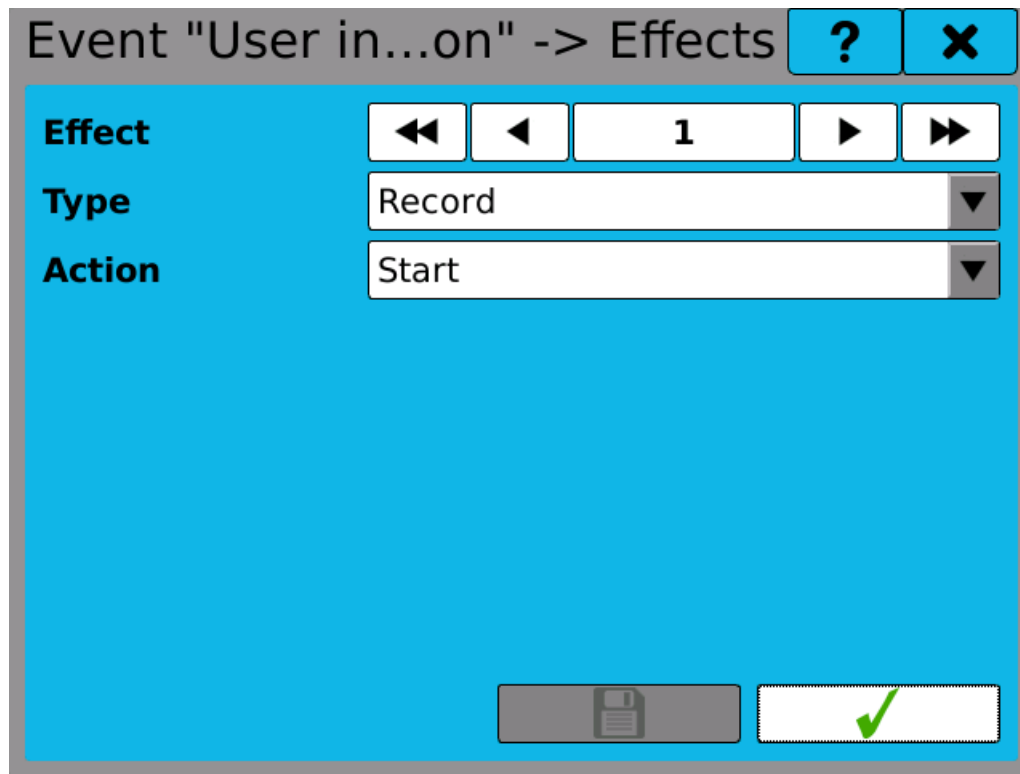

Effect configuration (type "Record")

6.4.3 Event Browser

Event diagnostics can be reviewed in dialogue "Event Browser", which can be found in the main menu, tab "Browse". Here you can see all the configured events, when was the last time they occurred and how many times they took place in total.

Note: events are also recorded in the system log.

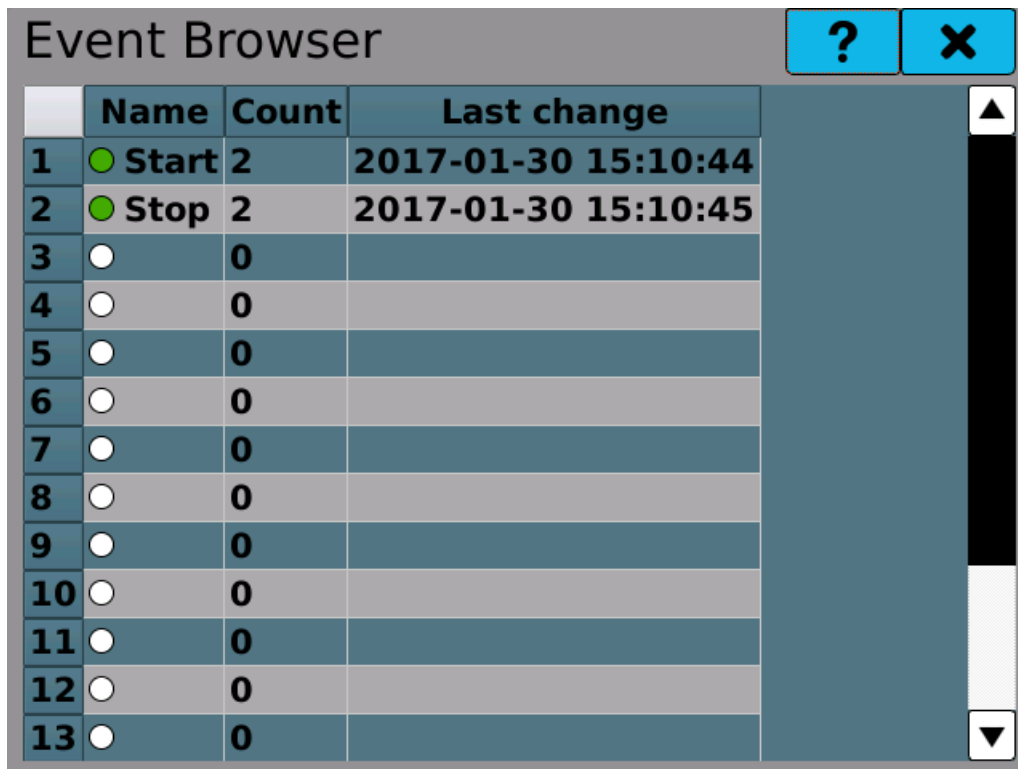

The image shows a software window titled "Event Browser". It contains a table with four columns: an index column, a "Name" column with a radio button, a "Count" column, and a "Last change" column. The first two rows are highlighted in grey. The first row shows "Start" with a count of 2 and a last change of "2017-01-30 15:10:44". The second row shows "Stop" with a count of 2 and a last change of "2017-01-30 15:10:45". Rows 3 through 13 show various other configurations, all with a count of 0. The window has a help button (?) and a close button (X) in the top right corner, and a vertical scrollbar on the right side.

	Name	Count	Last change
1	<input checked="" type="radio"/> Start	2	2017-01-30 15:10:44
2	<input checked="" type="radio"/> Stop	2	2017-01-30 15:10:45
3	<input type="radio"/>	0	
4	<input type="radio"/>	0	
5	<input type="radio"/>	0	
6	<input type="radio"/>	0	
7	<input type="radio"/>	0	
8	<input type="radio"/>	0	
9	<input type="radio"/>	0	
10	<input type="radio"/>	0	
11	<input type="radio"/>	0	
12	<input type="radio"/>	0	
13	<input type="radio"/>	0	

Overview of event configuration and statistics in Event Browser

7

Parameter selection window

7 Parameter selection window

There are five groups in the parameter selection window, from which the parameters can be selected.



Not used. Parameter will be erased.



I/O cards. It will select one of the card channels.



Node. It will select one of the nodes.



Constant. It will select one of the named constants.



Value. It will directly record the unchanging value.

7.1 Parameter "Not used"

Selecting this option you will erase the symptom used while setting records, screens, mathematical functions, and similar.

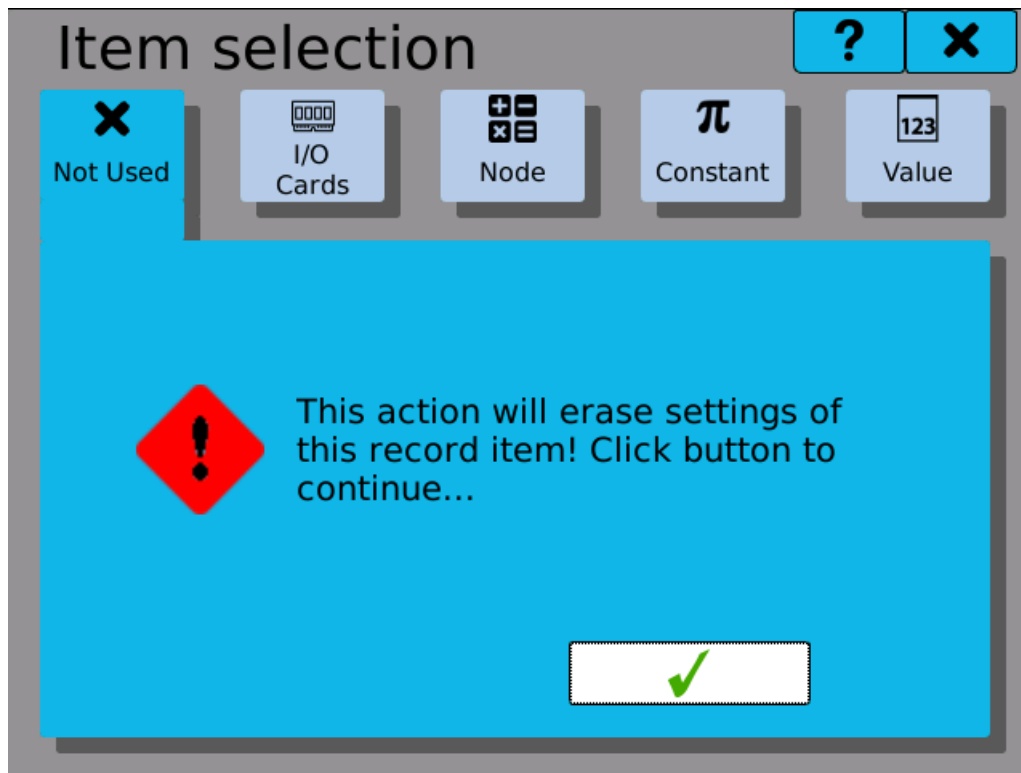

Selection "Not used"

7.2 Parameters from the I/O cards

Parameter selection from the I/O cards consists of selecting the needed card position, the channel, and the actual parameter.

- Position** Position of the card we are going to set. Buttons ◀ ▶ serve for rolling among the plugged-in cards. (Example: If there is no card on position A3, the setting will not offer it).
- Type** Type of the card plugged-in on the specified position. Type of the card cannot be changed. Informative text.
- Channel number** Channel number, from which we want to select the register. Buttons ◀◀ ◀ ▶▶▶ serve for rolling among the channels. The number of possible channels is determined by the card, from which we select the parameter.
- Register** Specific value of the channel, which is used as a parameter for settings of the nodes, screens, records and the like.

Item selection

Not Used I/O Cards Node Constant Value

Position ◀ B3 ▶

Type IN.4 (12 voltage inputs)

Channel ◀◀ ◀ 3 ▶▶▶

Register Electrical value ▼

✓

"IO" selection

7.3 Parameters from the nodes

Parameter selection from the nodes consists of selecting one of the defined nodes. If we add a parameter into the node, we can select the option "**Currently edited node**", which will use the currently edited node and by copying the settings among the nodes it will change according to the current node (so e.g. for node 0 there is the parameter node 0, for node 10 there is the parameter node 10).

- Currently edited node** If you add a parameter into any of the nodes, you can select this option. Otherwise, the option is disabled.
- Other nodes** Standard option. Enables selection from all defined nodes.
- Node** Node number we want to select.

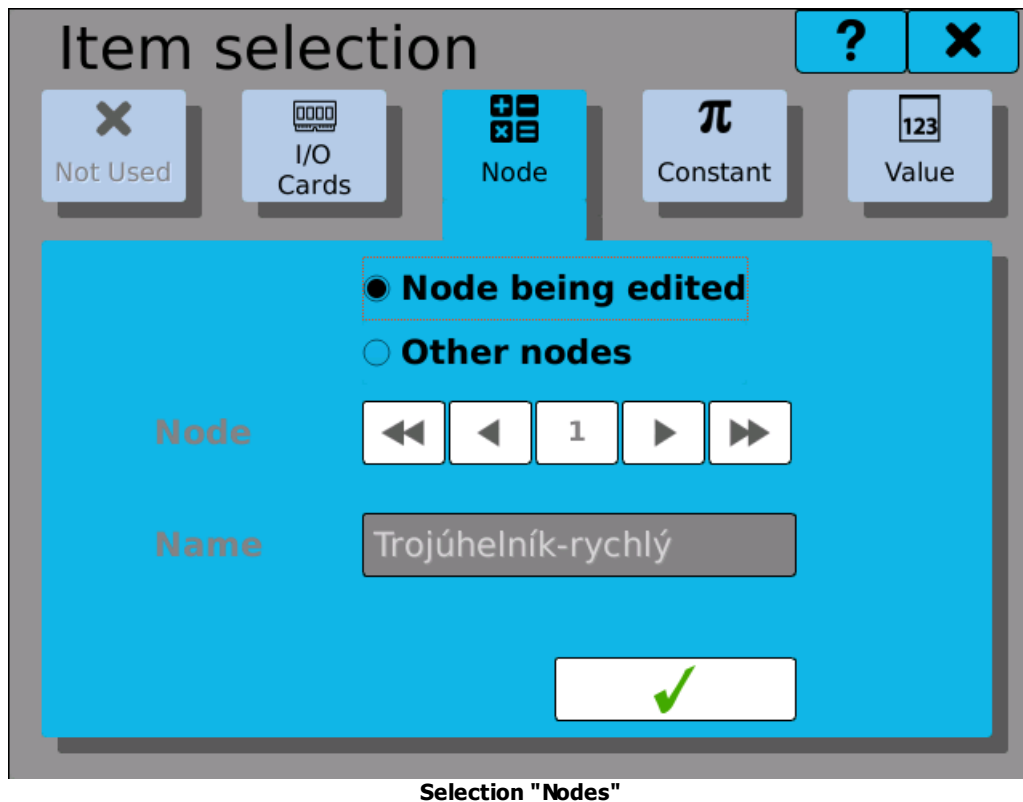

Item selection

Buttons: Not Used, I/O Cards, Node, Constant, Value

Options: Node being edited, Other nodes

Node: [Left Arrow] [Left Arrow] [0] [Right Arrow] [Right Arrow]

Name: Sinus-fast

[Green Checkmark]

Other nodes

7.4 Parameters from the constants

Parameter selection from the constants consists of selecting a defined, named constant.

Constant	Number of the constant we want to select.
Name	Number of the constant we chose in the previous settings.
Value	Value of the constant we chose in the previous settings.

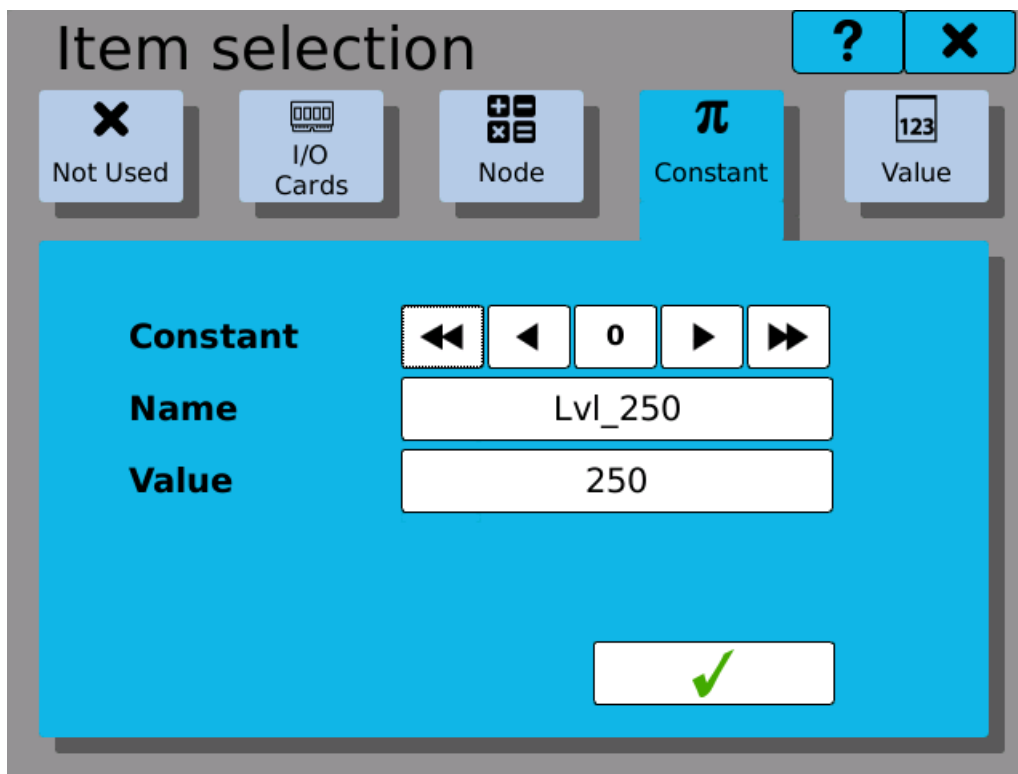

Selection "Constant"

7.5 Parameter value

Setting a fixed value consists of writing just a number into the box.

Value The box for setting fixed value.

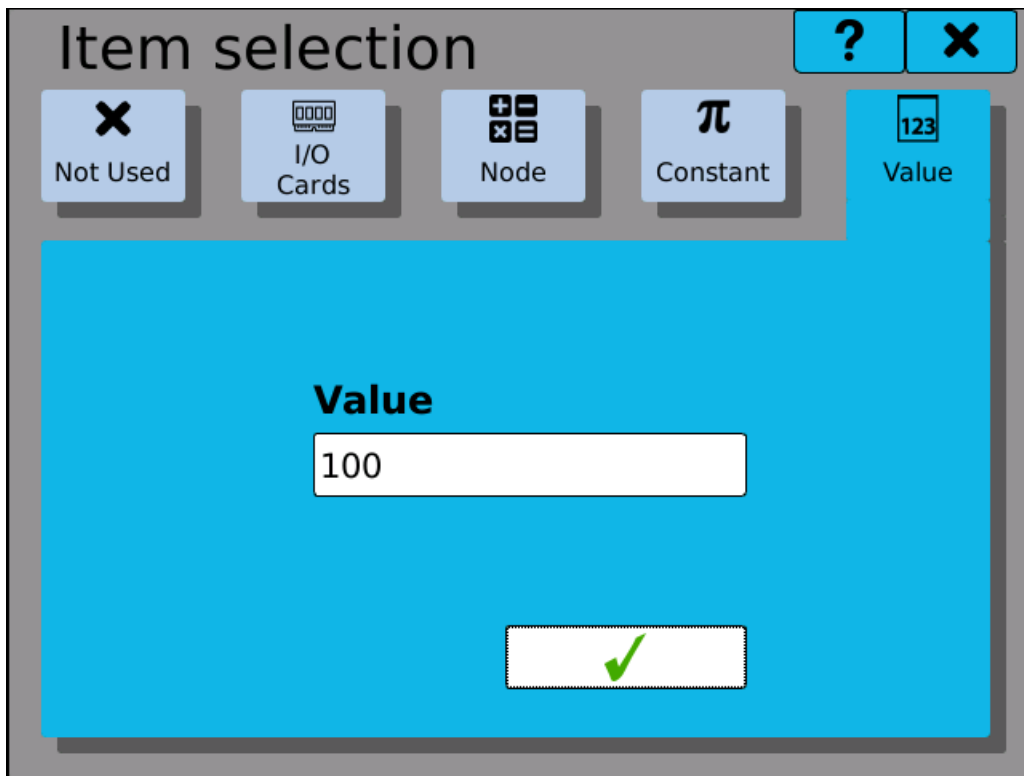

Selection "Value"

8

Selecting item from a group

8 Selecting item from a group

In the window for selecting items from the group you can see a chart overview of all items in the group as well as the colors of each group. The selection is always limited to a certain number of items that you can select together.

For example, for the **records** it is up to 16 items.

For the **running chart** it is up to 4 items.

For other **graphic elements** it is only 1 item.

As soon as the maximum number of selected items is reached, the other ones are disabled and they can not be selected.

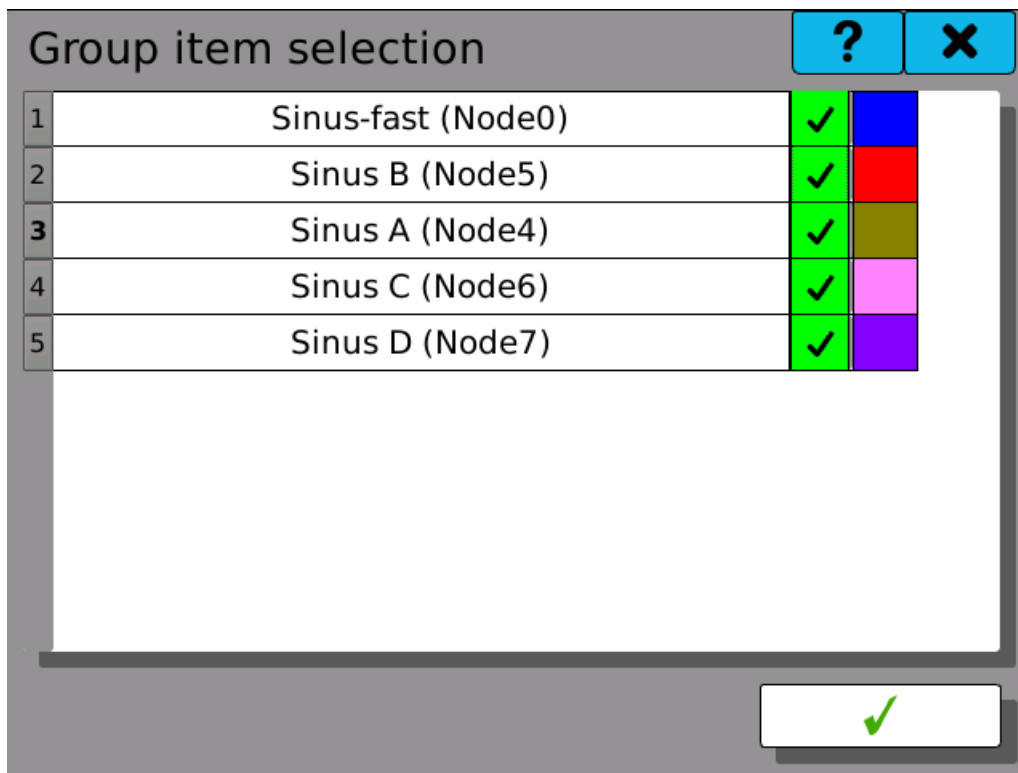

Selecting item from the group

Group item selection ? X

1	Sinus-fast (Node0)	✓	Blue
2	Sinus B (Node5)	✓	Red
3	Sinus A (Node4)	✓	Olive
4	Sinus C (Node6)	✓	Pink
5	SIN_5s_B (Uzel5)		Yellow
6	SIN_5s_C (Uzel6)		Brown
7	SIN_5s_C (Uzel6)		Purple

✓

Selecting item from the group with a maximum number of selected parameters

9 Date and time settings

Using buttons ◀ ▶ you move among the months. A click on the current month unrolls the month selection. A click on the year will display up and down arrows ▲ ▼ for the change of the year. For time settings click on the hour or minute box. By the up and down arrows ▲ ▼ you set the value of the marked field (hours and minutes).

Selection of a calendar field marks the current day, and a click on the button  confirms the selection and resets the date and time.

All records must disabled while setting date and time!

Setting of date and time ? X

		◀ April ▶			2016 ▶		
	Mon	Tue	Wed	Thu	Fri	Sat	Sun
13	28	29	30	31	1	2	3
14	4	5	6	7	8	9	10
15	11	12	13	14	15	16	17
16	18	19	20	21	22	23	24
17	25	26	27	28	29	30	1
18	2	3	4	5	6	7	8

Time: ▲
▼



Date and time configuration

10 Timezone settings

The timezone is an important parameter, used throughout the device. To guarantee consistency of displayed and stored time in records, it is important to set it properly.

Start by selecting your region and then choosing the appropriate location from the menus. (Used naming convention follows the official IANA timezone database).

We recommend to also use automatic daylight saving whenever possible.

After choosing the appropriate configuration, save it by clicking on the  button.

Warning: all records must be disabled while setting the time zone!

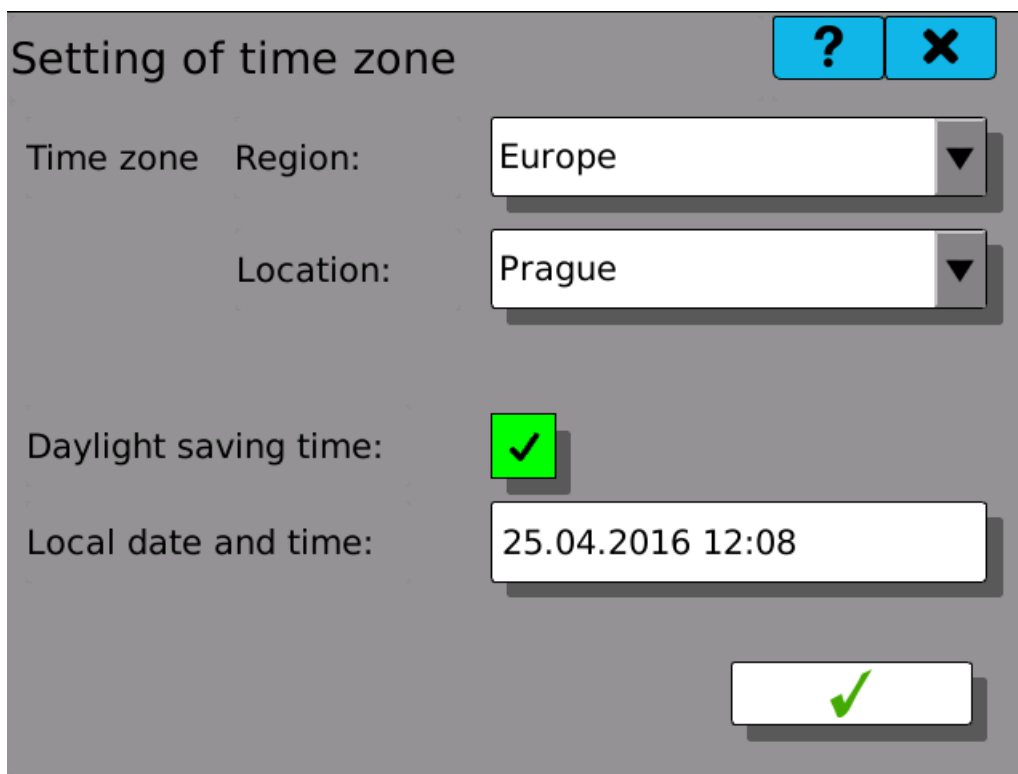

Setting of time zone

Time zone Region: Europe

Location: Prague

Daylight saving time:

Local date and time: 25.04.2016 12:08

Timezone configuration

Technical note: the device internally stores all time information in UTC. Also records are stored in this way together with a note about configured timezone. This way it is possible to ensure that the timestamps are always clearly defined and there are no data losses while transitioning from daylight saving time to normal.

11 Language settings

Language settings of the device. This option affects user interface and language of generated files. Changes take effect immediately after clicking the tick button.

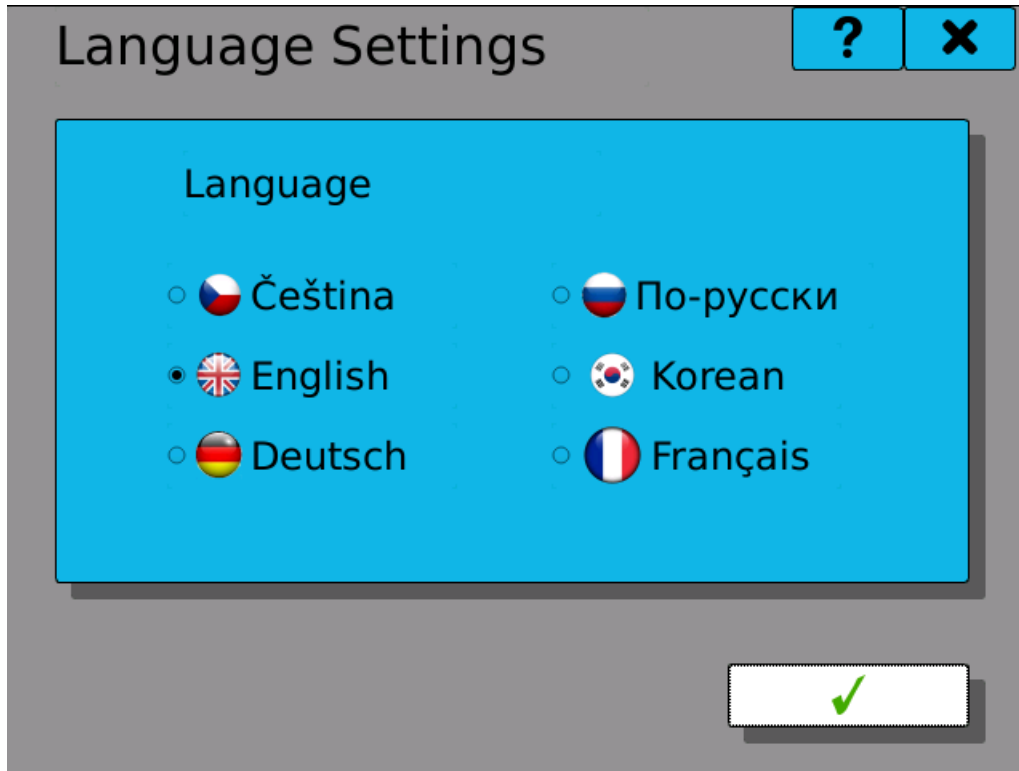

Language settings

12 Diagnostics

It serves to check the functions of the OMR700. We can diagnose function of the I/O cards, run of the secondary core, information on the motherboard, status of connection, and an overview of memory occupation of both the fix and portable storage media.



I/O cards. It moves you to the card overview and to the selection of one card for diagnostics.



Secondary core. It displays information on firmware and status of the secondary core.

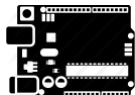

Motherboard. Information on temperature, light exposure, and power supply of the motherboard.



Connection. Information on connection via Ethernet, USB and/or WiFi.



Storage. Overview of memory occupation of both the fix and portable storage media.

12.1 I/O Cards

Overview window of the plugged-in cards. A click on the card field gets you to the card status report.

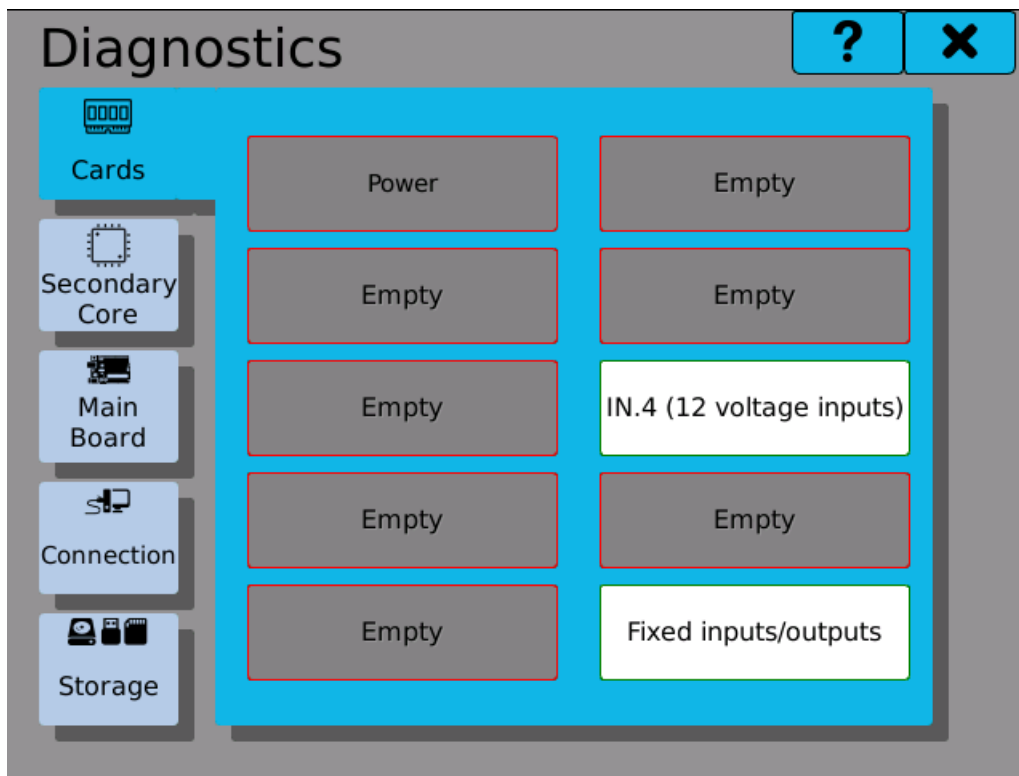

Cards overview

12.1.1 Card diagnostics

State and summary information for the card in question.

Some of the displayed values are useful only when solving issues with IO card.

Card type	Type of the card.
Card ID	Identification of the card.
Serial Number	Serial number of the card.
HW version	Hardware version of the card.
FW version	Firmware version of the card.
State	Ready, Enumeration.
Card State	The options are Reset, Initialization, Run, and Stopped.
State Bits	State bits of the diagnosed card.
Calibration state	State of IO card calibration. Value "valid" shows that the card is calibrated correctly.
Frame rate	The speed of data transfer between the card and the auxiliary core. The value expresses the count of transferred data frames per second.

A click on the button "Diagnostics of registers" takes you to the diagnostics of the individual values on the card in question.

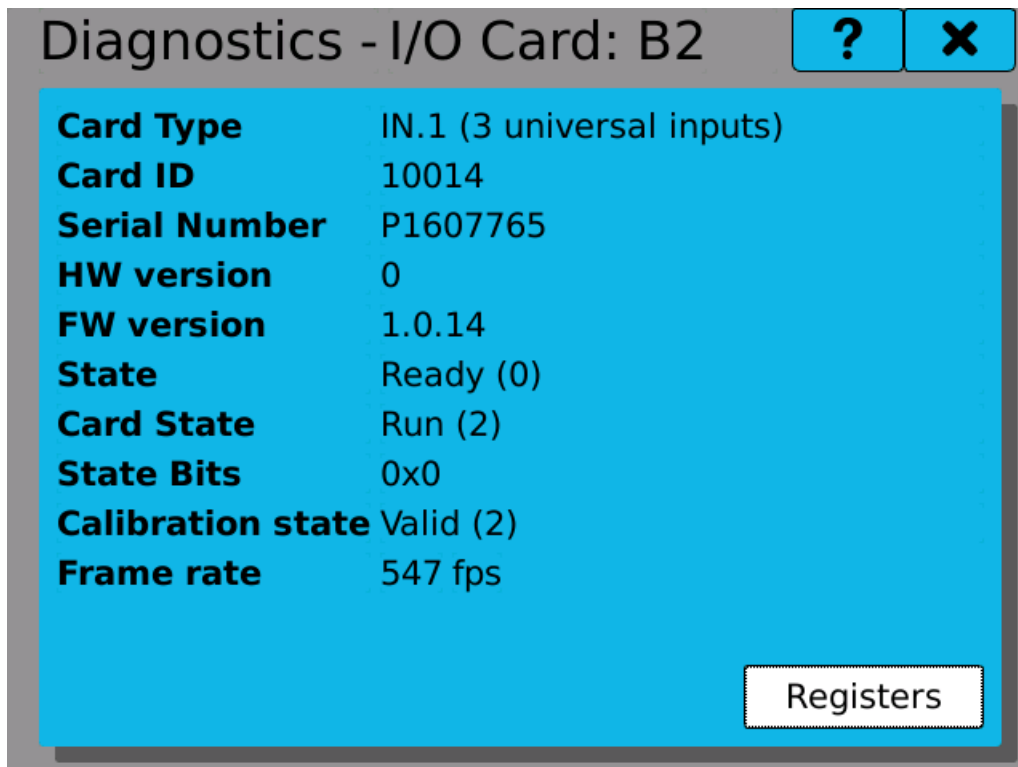

Card diagnostics

12.1.2 Diagnostics of the card registers

Values in the card registers. Values can be either editable (from the diagnostics a value can be imposed on them), or not editable (read only, no value can be imposed on them).

IN.4 (12 voltage inputs) ✖	
Direct Data 0	32768
Direct Data 1	32768
Direct Data 2	32768
Direct Data 3	32768
Direct Data 4	32768
Direct Data 5	32768
Direct Data 6	32768
Direct Data 7	32768
Direct Data 8	32768

Register diagnostics

12.2 Secondary Core

State and information about the secondary core of the OMR 700.

Firmware	Firmware version running on the secondary core.
State	State of the secondary core. There are two options: Run or Stopped.
ICC State	Shows the state of inter-core communication. "Valid" means communication is working.
M4 Time	Shows current time set in the auxiliary real-time core.
M4 Time Sync	Displays the difference between the time, set in the main system core and the auxiliary real-time core.

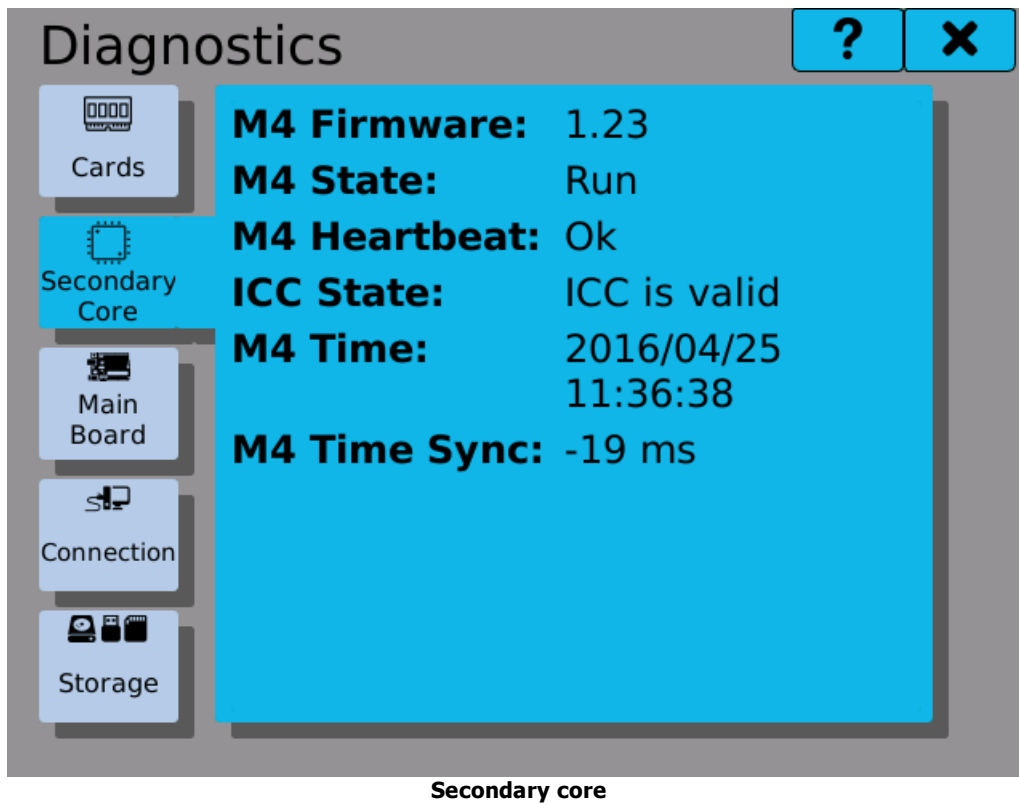

12.3 Connection

Status and information about the network connection of the recorder OMR700. The diagnostics can be switched over among the tabs "Common", "Ethernet", "USB" and "WiFi".

- Common** Information common for all types of connection. E.g. the name of the recorder network.
- Ethernet** Information about the Ethernet connection. There you will find connection status, MAC address, IP address and subnet mask.
- USB** Information about Ethernet connection via USB. There you will find connection status, MAC address, IP address and subnet mask.
- WiFi** Information about wireless connection to the network. There you will find connection status, MAC address, IP address and subnet mask.

Connection status:

Down - the interface is disabled.

Up - the interface is enabled but not active.

Up and running - the interface is enabled and active.

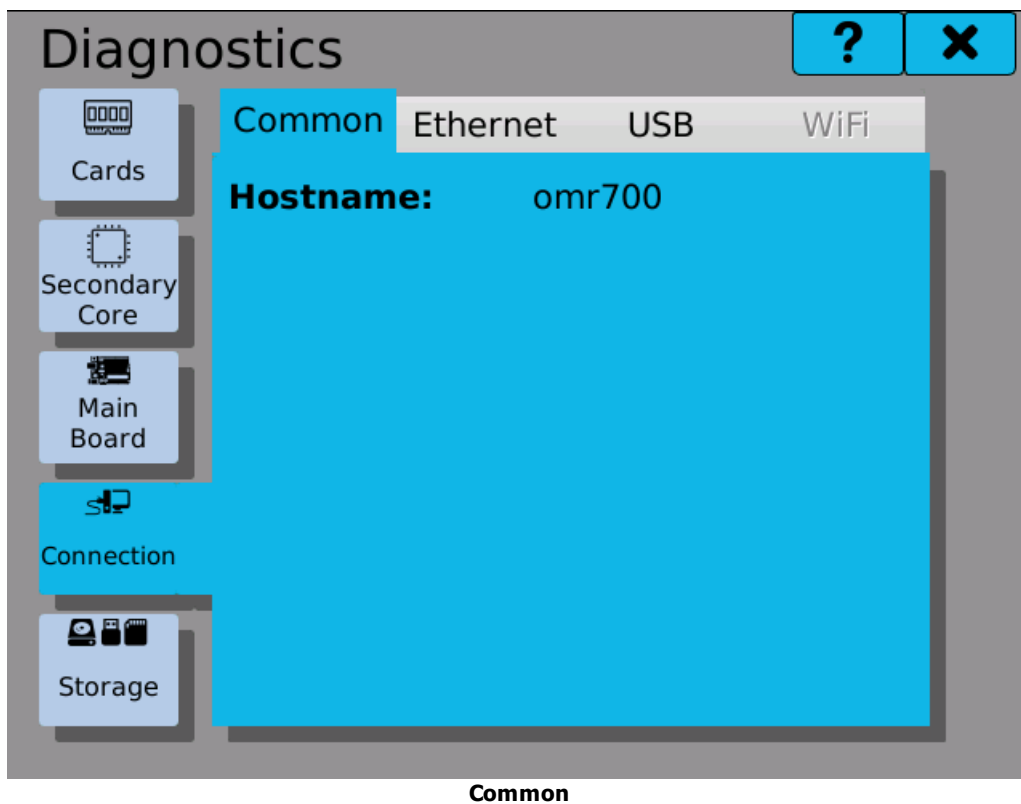

The screenshot shows a 'Diagnostics' window with a sidebar on the left containing icons for 'Cards', 'Secondary Core', 'Main Board', 'Connection', and 'Storage'. The 'Connection' icon is highlighted. At the top, there are tabs for 'Common', 'Ethernet', 'USB', and 'WiFi', with 'Ethernet' selected. The main content area displays the following information:

State:	Up and running
MAC:	B4:2A:39:22:B1:A8
IP Address:	192.168.1.56
Netmask:	255.255.255.0

Ethernet

The screenshot shows the same 'Diagnostics' window, but with the 'USB' tab selected. The main content area displays the following information:

State:	Down
MAC:	00:11:22:33:44:55
IP Address:	N/A
Netmask:	N/A

USB disconnected

12.4 Storage

Status and information on how full is the capacity of the internal storage and of the removable storage media. The diagnostics can be switched over among the tabs "Internal", "USB" or "SD Card".

- Internal** Information about free space in the internal storage.
- USB** Information about free space on USB Flash Drive.
- SD Card** Information about free space on SD card.

Button  updates capacity of the media.
 If removable medium is not up, "N/A" is displayed.

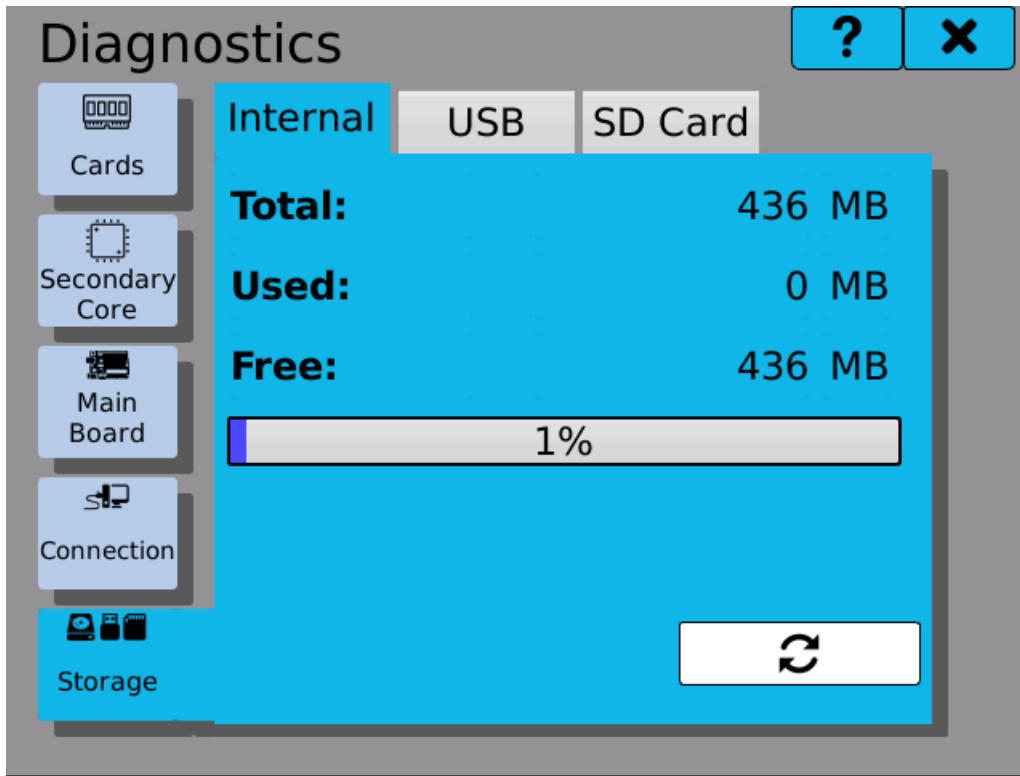

Internal storage

Diagnostics

Internal **USB** SD Card

Total: N/A MB
Used: MB
Free: MB

0%

Storage

Total:	N/A MB
Used:	MB
Free:	MB

USB down

Diagnostics

Internal USB **SD Card**

Total: 3715 MB
Used: 84 MB
Free: 3631 MB

3%

Storage

Total:	3715 MB
Used:	84 MB
Free:	3631 MB

SD card

13 Device software update

The device software consists of two independent parts: system and firmware. Firmware can be sometimes updated separately, if the current installed system is suitable. However when updating system, firmware must be updated as well.

There are two separate, independent, equal copies of system and firmware, which can be switched at will if necessary. The currently running copy is addressed as "Active" and the other one as "Backup". While updating, the backup copy is rewritten and after the device reset the formerly backup copy becomes the active one.

Update procedure:

- 1) The update window opens by an enabled selection between USB flash drive and SD card. Kindly plug-in one of these two storage media, make the same selection on the screen and press the button "**Load packages**".
We recommend that you create a folder "**omr700-upgrade**" on the storage media .
- 2) Pressing the button "**Load packages**" opens two boxes: Selection of the found firmware and selection of the found system. Empty boxes mean that no installation packages were found. Please check location and names of the installation packages. Your click on the box or on the down arrow unrolls the menu of found firmware or system installation packages. Select the requested firmware and system and continue by clicking the button "**Update**". Firmware (or software) runs under the Linux Operating System and the update can be performed either for firmware itself or for system + firmware together. Updating just the system is not possible. If you can not find the desired firmware version, the selection box turns red and it can not be edited. The error will be cleared by changing the firmware to a version that finds the required version on the storage media or by adding the correct version of the system to the storage media. Select the latest versions. Those are the ones with the highest version numbers.
- 3) Pressing the button "**Update**" starts firmware and system updates. The progress of updating is displayed on two indicators. The upper indicator shows the progress of the entire update process and the lower one shows the progress of the currently executed update step. The steps are: Update preparation, system update, firmware update, update end. There is a text description of the current process under the indicators .
- 4) The process of updating can be stopped by the button "**Stop**". It is not recommended to interrupt the updating process, because it may damage the backup files. Use it only in an extreme situation. If the button "**Stop**" turns gray (you can not press it) the updating process is in progress and it can not be interrupted. Please wait for completion of this step.
If the process is stopped by the button "**Stop**", the error window "**Interrupted with error**" pops up.
- 5) After a correct completion of the update a message pops up, which warns that changes will not take effect until the device has been restarted. You can either confirm or cancel this option. If it is canceled, switching to the backup version is possible in

two ways: Either at the next start of the device or by pressing the button "**Switch to backup**".

- 6) If for some reason the update is unsuccessful, an error window "**Interrupted with error**" pops up and the error is described in a text form.
- 7) Fast troubleshooting:

Message	Solution
No connection with the server	Check connection to Internet
Loading failed	Check connection to Internet
Update package not found	Check if the packages are on the storage media or if they have been properly named
Check sum error	Package error. Download and save it on the storage media again
The update is already running	Stop the running update or restart the recorder

In case of any other error kindly contact the manufacturer!

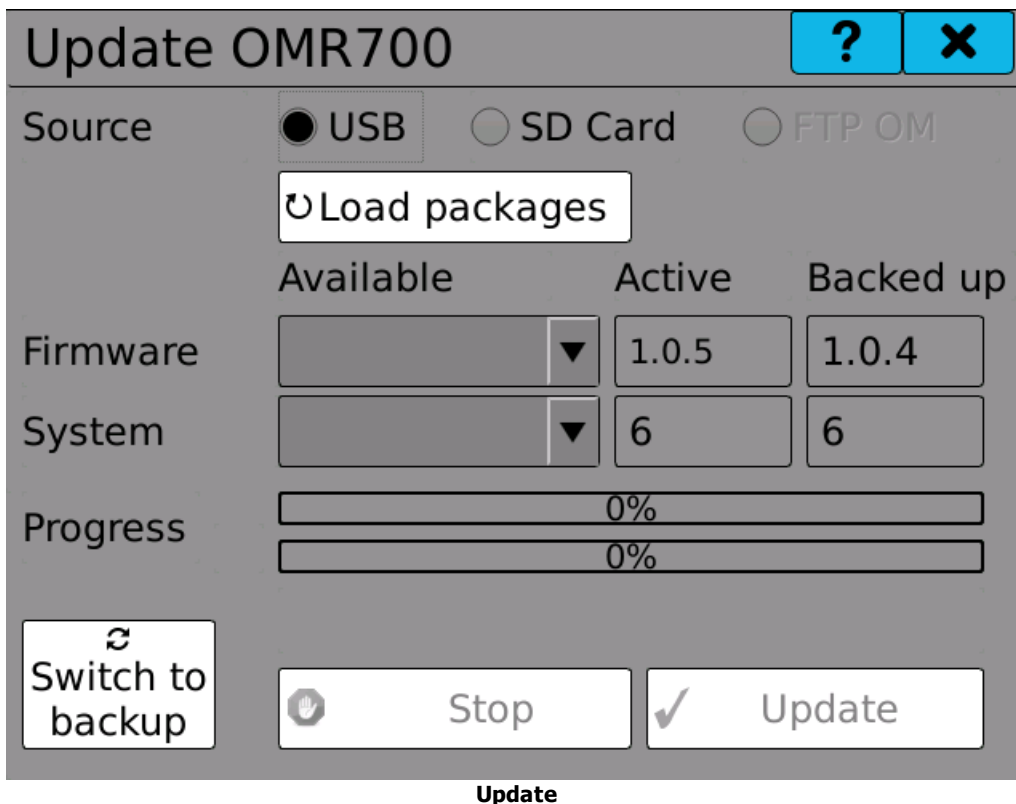

14 I/O Card update

All the I/O cards (except for the fixed I/O card at position B1) have their own firmware. This firmware is tied directly to the physical card, independent of the recorder firmware and can be updated separately.

Update procedure:

- 1) Choose a card from the card selector. Only the currently plugged-in cards will be visible. Version number of the currently running card firmware will become visible in the "**Current Firmware**" box.
- 2) Insert removable media with the update package, select it and click on the "**Load packages**" button. If an appropriate package is found, it's version number will be visible in the "**Available**" selector.
We recommend that you create a folder called "**omr700-upgrade**" on the storage media to store the packages.
- 3) Select the version of firmware you want to update to.
- 4) Pressing the button "**Update**" starts the update of the card firmware. Its progress is displayed by the progress bar. The whole update process should take just a few seconds.
- 5) After the update procedure finishes, the cards are put back to operation and are prepared for immediate use.
- 6) If for some reason the update is unsuccessful, an error window "**Interrupted with error**" pops up and the error is described in a text form.
- 7) Fast troubleshooting:

Message	Solution
No connection with the server	Check connection to Internet
Loading failed	Check connection to Internet
Update package not found	Check if the packages are on the storage media or if they have been properly named
Checksum error	Package error. Download and save it on the storage media again

In case of any other error kindly contact the manufacturer!

Update card firmware ? ✕

Card [B4]:OUT.1 (4 relay outputs) ▼

Source SD Card USB FTP OM

Firmware Available Current

1.0.5

Progress

Progress

Update

15 User administration

User administration serves for creation and subsequent modification of users, their access rights and passwords.

The following can be edited in the user administration:

- User number** Number of the currently viewed or edited user.
- Name** Name of the user. Under this name you log in. The name can consist of up to 32 characters.
- Level** Level of user access rights.
- Password** Password has to be at least four and at most eight characters long. It can consist of letters, numerals, hyphens and underscores. The password is hidden by default but you can view it.
- Change password** To change the password, kindly click the button  , which opens the password change dialogue. If you are authorized to change the password of a lower level user, fill in just the boxes "New password" and "Repeat password".

Access settings

?
X

User Number

◀◀
◀
1
▶
▶▶

Name

Level

Administrator
▼

Password

●●●●●●●●

Show password

Edit password

🔒

✓

Users list

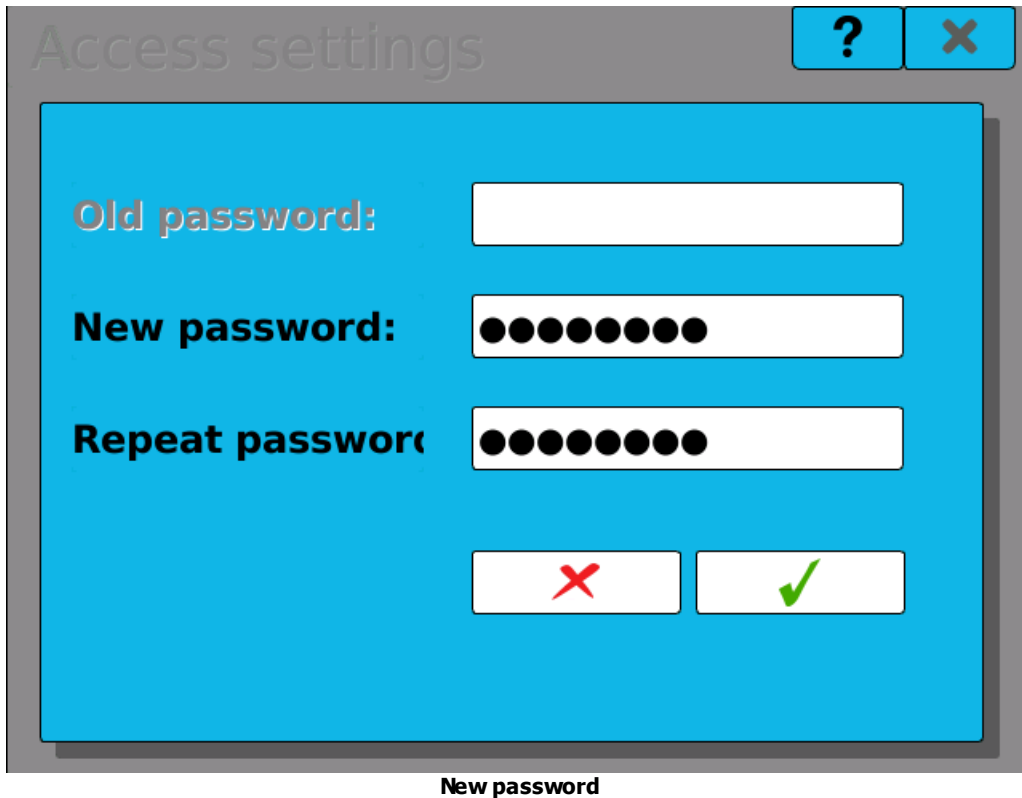

List of user levels

Index	Group	Access level
0	Operation	Not logged in
1	Operation	User
2	Operation	Operator
3	Operation	Master
4	Service	Service
5	Configuration	Configurator
6	Configuration	Administrator
7	Configuration	Producer
8	Configuration	Universal

Access right table

Action	Access right (by user level index)								
	0	1	2	3	4	5	6	7	8
Screen switching	C	Y	Y	Y	Y	Y	Y	Y	Y
Current error browsing	N	Y	Y	Y	Y	Y	Y	Y	Y
Starting and stopping of recording	N	N	Y	Y	Y	Y	Y	Y	Y
Changing system time	N	N	Y	Y	Y	Y	Y	Y	Y
Moving recorder data	N	N	Y	Y	Y	Y	Y	Y	Y
Browsing logs	N	N	Y	Y	Y	Y	Y	Y	Y
Displaying storage diagnostics	N	N	Y	Y	Y	Y	Y	Y	Y
Configuration of display and sound	N	N	Y	Y	Y	Y	Y	Y	Y
Acknowledging errors	N	N	N	Y	Y	Y	Y	Y	Y
Changing constant values	N	N	N	Y	Y	Y	Y	Y	Y
Display meter configuration	N	N	N	Y	Y	Y	Y	Y	Y
Diagnostics (I/O, system and connection)	N	N	N	N	Y	Y	Y	Y	Y
Event browser, Fieldbus browser	N	N	N	N	Y	Y	Y	Y	Y
Device and card firmware update	N	N	N	N	Y	Y	Y	Y	Y
Card calibration	N	N	N	N	Y	Y	Y	Y	Y
Record configuration	N	N	N	N	N	Y	Y	Y	Y
Function configuration (nodes, IO, timers, ...)	N	N	N	N	N	Y	Y	Y	Y
Start-up configuration	N	N	N	N	N	Y	Y	Y	Y
System event configuration	N	N	N	N	N	Y	Y	Y	Y
Button configuration	N	N	N	N	N	Y	Y	Y	Y
Network configuration	N	N	N	N	N	N	Y	Y	Y
Device software reset	N	N	N	N	N	N	Y	Y	Y
Timezone configuration	N	N	N	N	N	N	Y	Y	Y
Language configuration	N	N	N	N	N	N	Y	Y	Y
User profile configuration	N	N	N	N	N	N	Y	Y	Y
Administrator account configuration	N	N	N	N	N	N	N	Y	Y

Producer account configuration

N	N	N	N	N	N	N	N	Y
---	---	---	---	---	---	---	---	---

- A ... Accessible
- N ... Not accessible
- C ... User-configurable

16 Warning, error and critical error

Tool for viewing the current warnings, errors, critical errors, and logs. If there is a critical error in the device, it must be confirmed (acknowledged).

In the window you can also switch over to the logs overview.

In the tab Current W/E you can switch over the levels of severity among warnings, errors, critical errors, or you can view all.

The overview of warnings and errors is presented in a spreadsheet-style divided into columns.

- L** Level column (color differences)
- Date** Date of the warning or error
- Time** Time of the warning or error
- Event** Text description of the warning or error

A click on the warning or error tab reveals details of the event. If the error is critical, it is to be confirmed (acknowledged) here

Logs		Current W/E		Calendar	Filter	Help	Close
All	Critical error	Error	Warning				
L	Date	Time	Event				
C	2016/0...	13:42:19	Power supply under limit				

Critical error

16.1 Warning or error details

In a detailed description can be found:

Level	Warning, error or critical error.
Time stamp	Date and time of the warning or error inception.
Source	Cause of the warning or error. It can be either the main processor, secondary processor or the plugged-in cards.
Event	Text description of the warning or error.
Value	Values associated with the warning or error. There can be up to 4 values.

If it is necessary to confirm (acknowledge) the error, click the button "Acknowledge". If you really want to acknowledge the error, a warning window pops up. Provided that the recorder is once again among the specified limits, the error disappears after its acknowledgment.

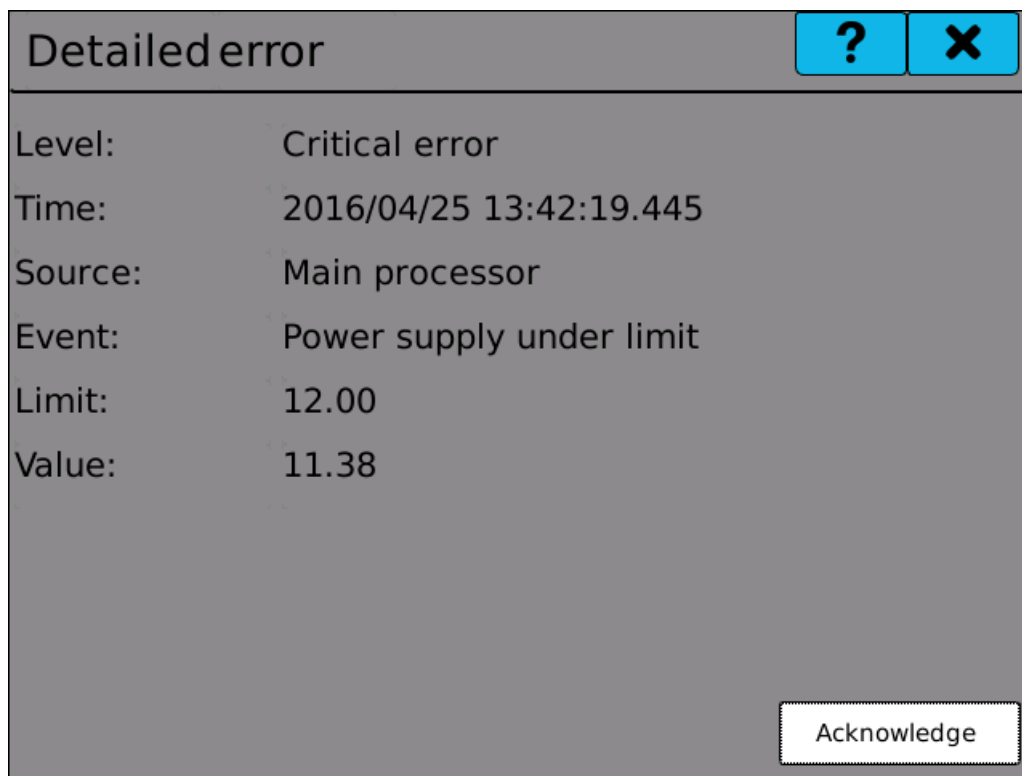

Critical error in detail

Detailed error ? X

Level: Critical error
Time: 2016/04/25 13:42:19.445
Source:
Event:
Limit:
Value:



Do you want to acknowledge this critical error?

Error acknowledgment

17 Display settings

Here you can adjust brightness (backlight) of the display or set the screensaver.

Backlight	Moving the slider to the left or right changes the intensity of the back light.
Screensaver	A click on the box unrolls the selection menu. There you can select the type of the screen saver.
Dim screen after:	The time after which the screen turns dim.
Start screensaver after:	The time after which the screensaver is put into operation.
Allow screen switching without login	Allows switching between configured screens even without logging in.

There is an option of switching over from display settings to sound settings and to programmable buttons. Just click on the tabs "Sound" or "Buttons".

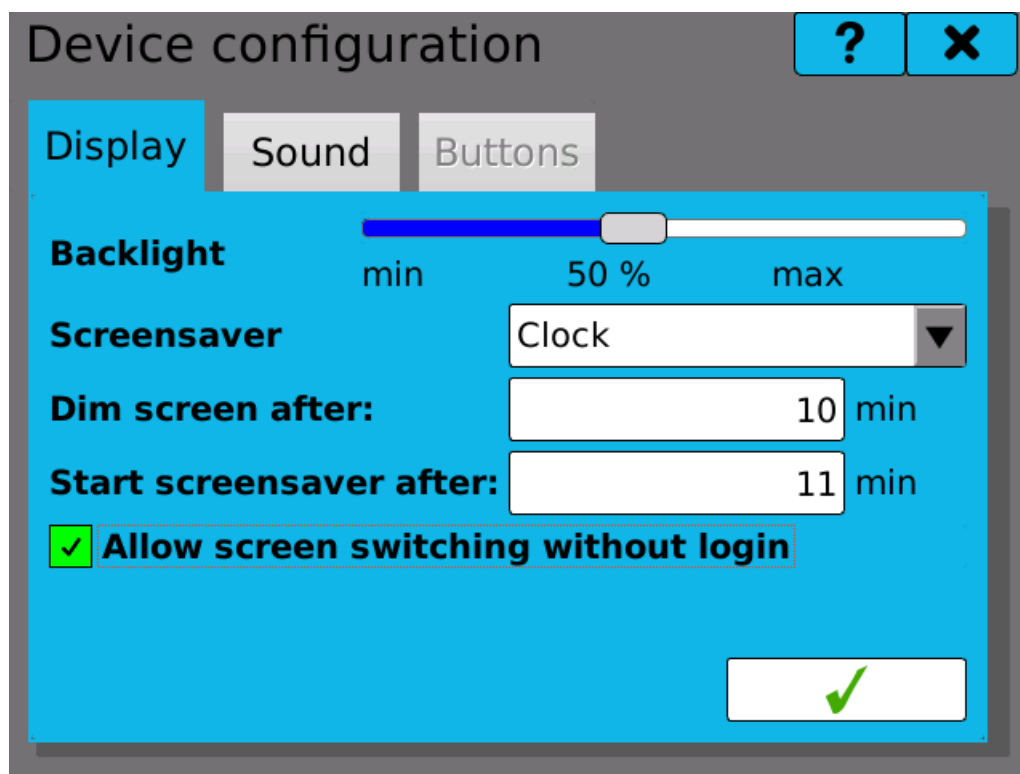

Display settings

18 Sound settings

Here you can set volume of sounds used in the device.

Volume Moving the slider to the left or right changes the sound volume.

There is an option of switching over from sound settings to display settings and to programmable buttons. Just click the tabs "Display" or "Buttons".

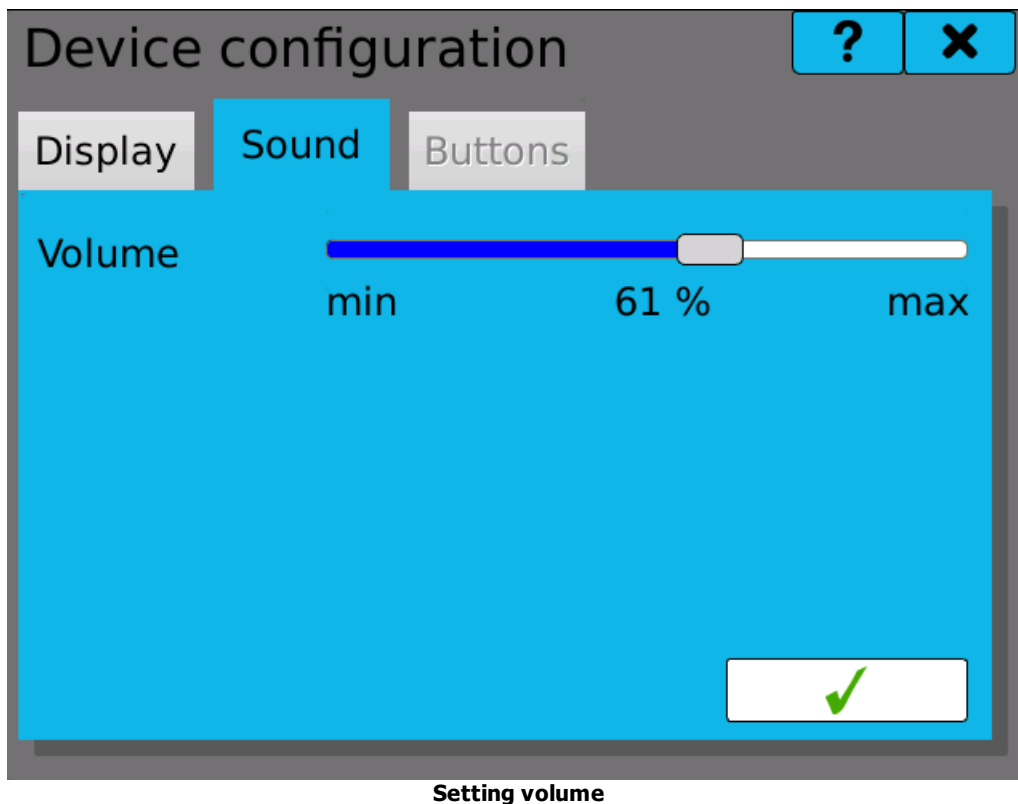



19 Configuration management

Configuration management

Backup

In the tab "Store" we select the storage media, where a backup package with configurations will be created. The options are USB flash drive, SD card or internal memory of the device. A click on the button  will create a package on the selected medium. The name of the package will be e.g. **omr700-cfg-1.0.1-2-1234567890-20160208-075603.tar.gz**, where "omr700-cfg" is unchangeable, "1.0.1-2" are firmware and system versions, "1234567890" is the serial number, and "20160208-075908" gives information about the date and time of the package creation. In this case it is on 08.02.2016 at 7:59:08.

Restoration

In the tab "Restore" we choose a storage medium, from which the restoration will be carried out and where we will look for the configuration package. The options are USB flash drive, SD card or internal memory of the device. Select one of these media and click on the button . If there are some valid configuration packages on the storage medium, the selection "Select file:" will be filled in. We again see the packages under the name **omr700-cfg-1.0.1-2-1234567890-20160208-075603.tar.gz** and we can select one of the offered packages. A click on the button  restores the configurations. To be able to load and use the new configuration, the device must be restarted. Therefore a warning window "Device will be restarted" will pop up.

Erase

The "Erase" tab can be used to delete configuration part by part or as a whole, if necessary. You can for example delete complete configuration of screens, if you need to recreate the layout from scratch. Deleting user account configurations requires access rights level "Universal".

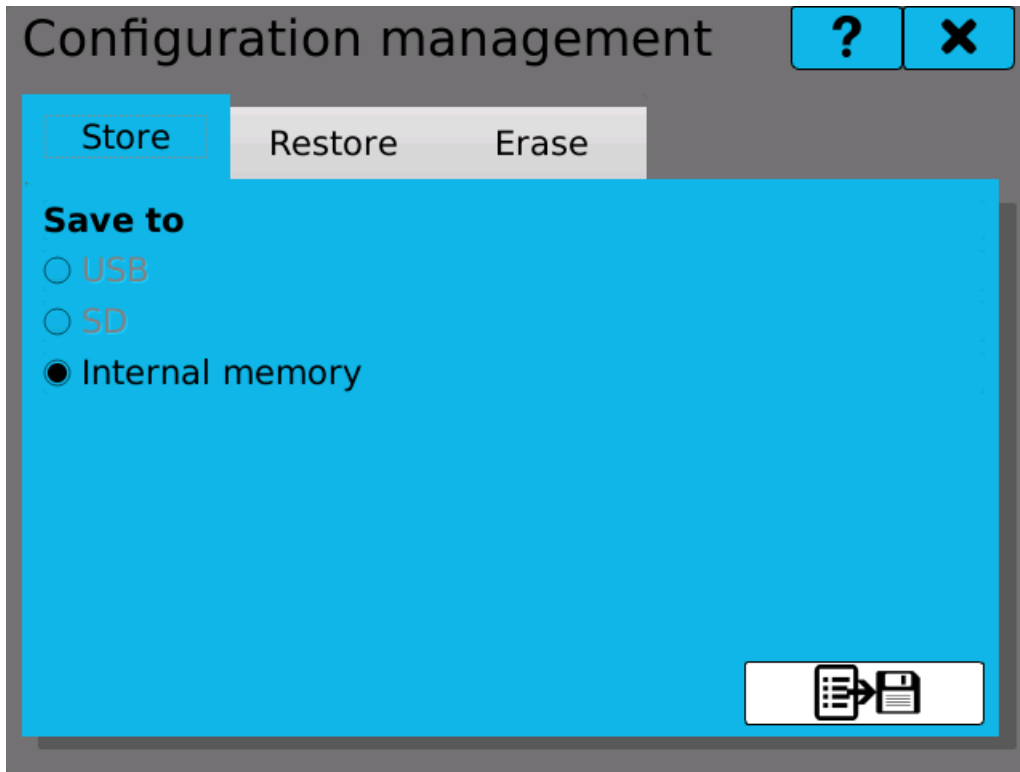

Storing configuration

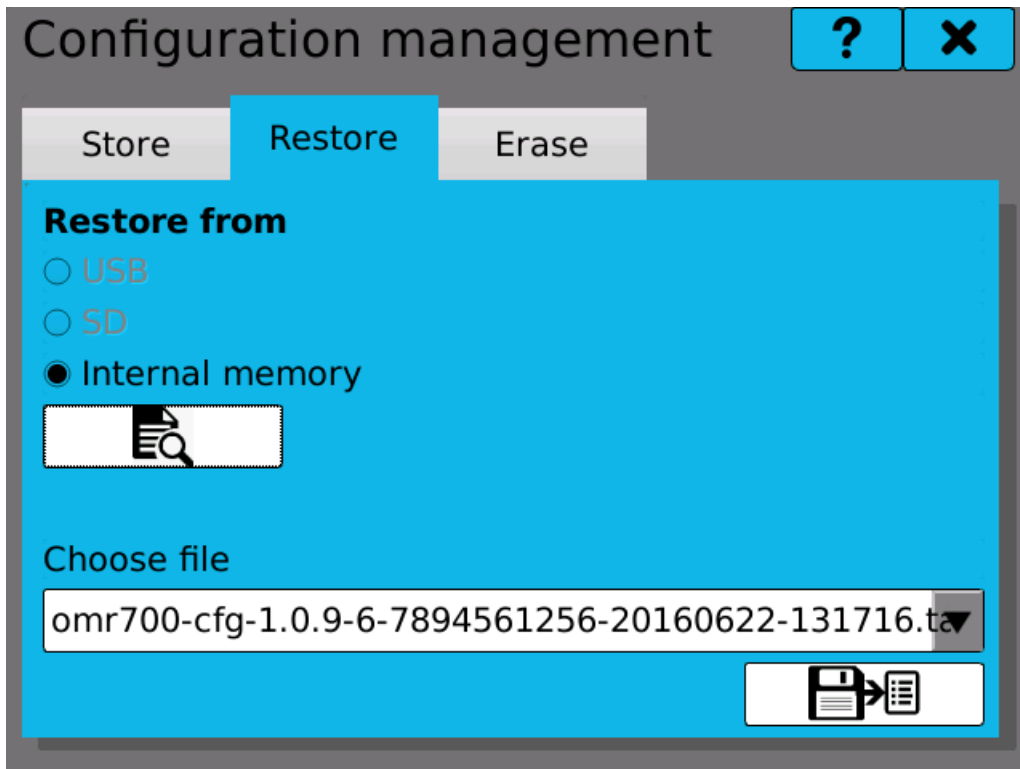

Restoring configuration

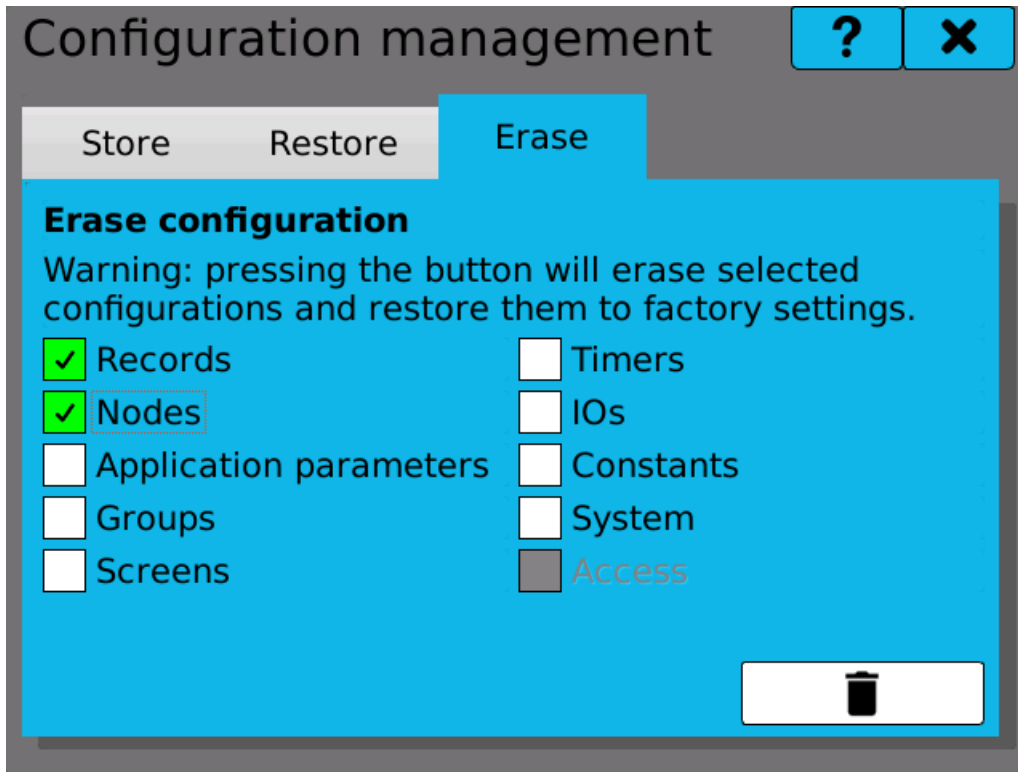

Erasing configuration

20 Storage management

A tool for copying, moving, and deleting stored logs and measured records in the internal memory.



The button to start copying logs or records. The files are copied and they stay in the internal memory.



The button to start moving logs or records. The files are copied and deleted from the internal memory. **The operation can not be undone!**



The button to start deleting logs or records. The files are deleted from the internal memory. **The operation can not be undone!**

To work with the stored logs:

By selecting a start and end date in the selection calendar (the calendar is opened by clicking on ▼) all existing logs in the specified time span are searched, and the resulting number and size is displayed on the screen.

A click on one of the buttons USB flash or SD card selects the memory medium, on which the logs will be copied/moved.

Clicking one of the buttons will start the file operations.

The log of the current day is displayed on the line "**Current log**". This log can be copied

only. Use the button  at the end of the line.

To work with the stored records:

In the tab "**Records**" you can select one of the stored records in the internal memory. This record will fill in the date and time of the first and the last stored record.

A click on one of the buttons USB flash or SD card selects the memory medium, on which the records will be copied/moved.

Clicking one of the buttons will start the file operations. Copying progress is displayed in the progress indicator.

Memory management ? X

Logs **Records**

Logs from: 04.05.2016 ▼ Logs to: 12.05.2016 ▼

Selected logs count: 3 Selected logs size:

Copy logs to:

USB flash
 SD card

Actual log:
Log_20160513.csv

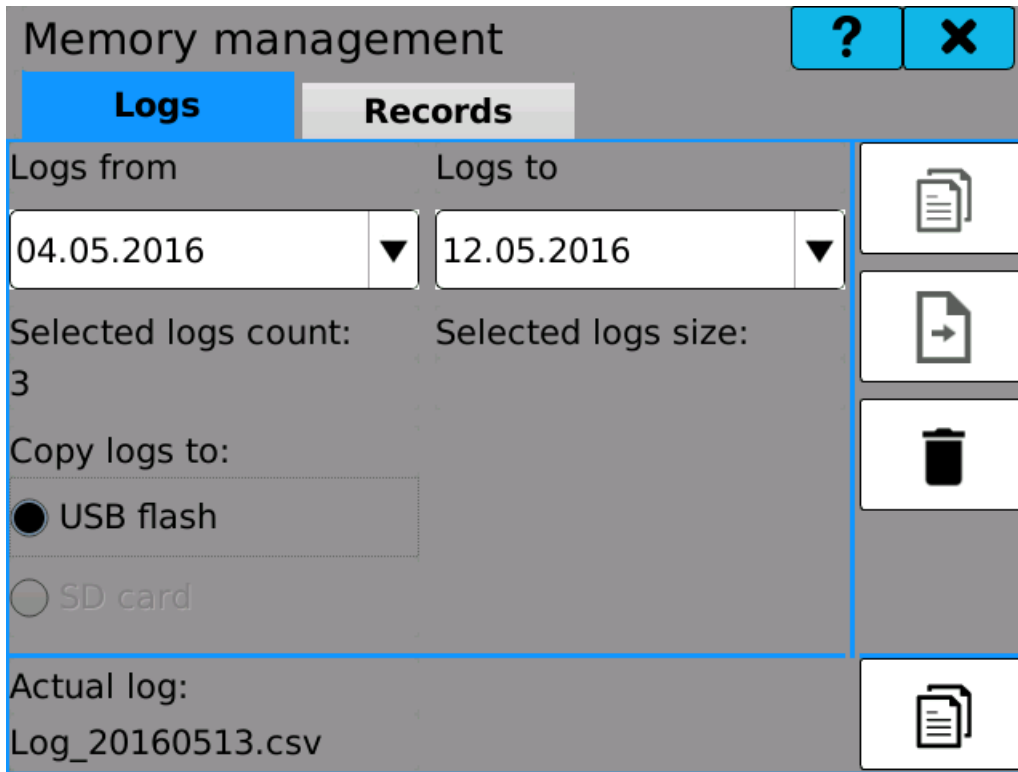

Logs management

Memory management ? X

Logs **Records**

Record:

Records from: 01.01.2000 ▼ Records to: 01.01.2000 ▼

00:00 ▲▼ 00:00 ▲▼

Selected files count:

Destination:

USB flash
 SD card

0%

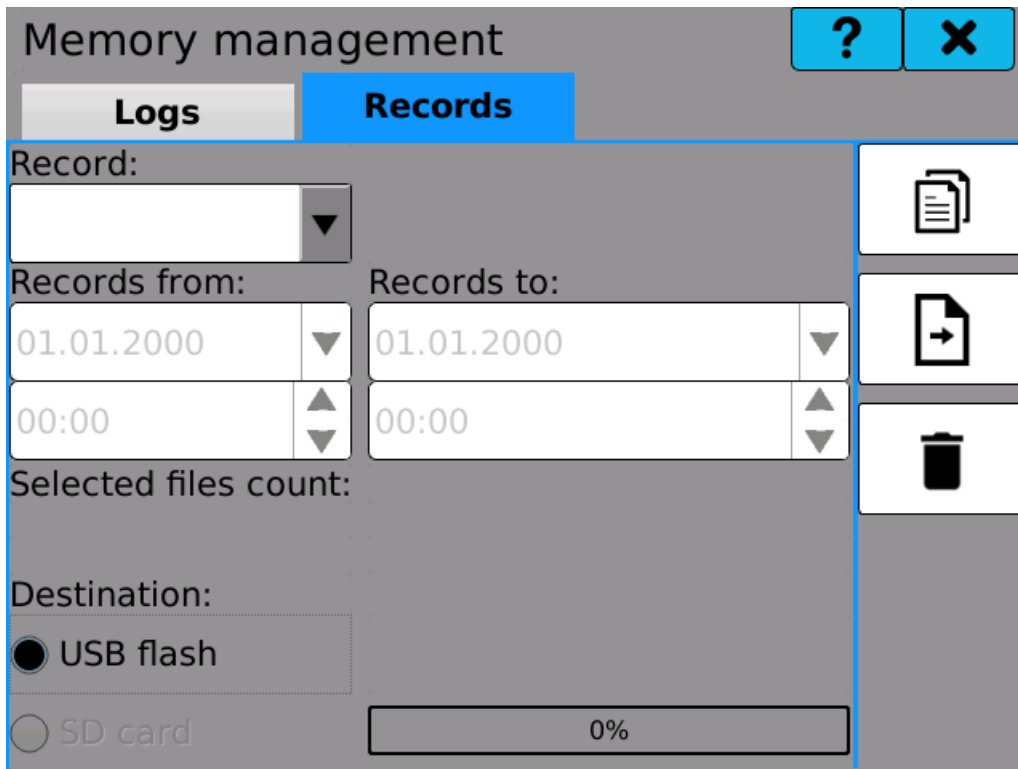

Records management

21 Connection settings

Tool for computer network access configuration

General	Common networking configuration and overview.
Ethernet	Ethernet connection settings
USB	USB Ethernet connection settings
WiFi	WiFi connection settings.

General:

Hostname configuration (device's network name)

Current networking status overview

The list of network interfaces allows to see their status and enable/disable them one by one.

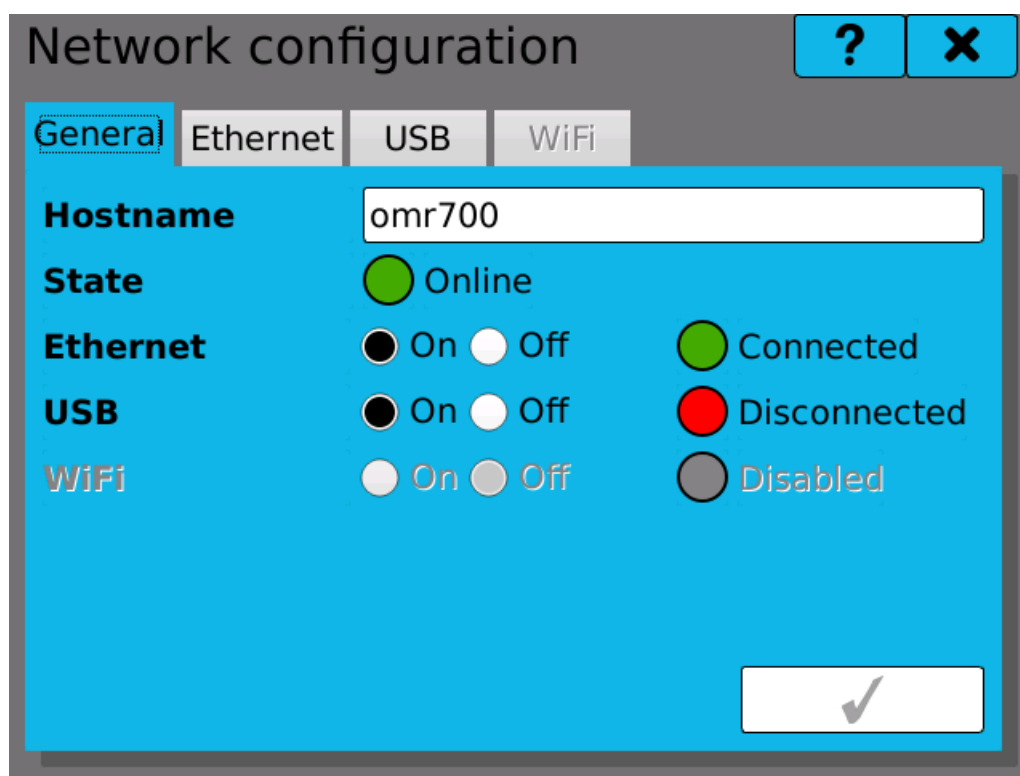

Network connection overview

21.1 Ethernet

Ethernet network connection is handled by the **"Wired"** service, eg. by fixed, cable connection.

The service is available when the Ethernet cable is connected and can show following

states:

Idle - the service is not active.

Disconnected - the service has just disconnected and is switching to the "Idle" state.

Failure - connection error has been detected.

Association - the service is currently trying to connect to the remote device.

Configuration - connection configuration is being loaded.

Ready - the service is connected to the network.

Online - the service is connected to the network and Internet connection is available.

IPv4 Address: Interface's IP address. It is either acquired automatically from the DHCP server or configured manually (IP version 4).

MAC Address: Interface's hardware MAC address.

The connection can be further configured by clicking on the  button.

Button "**Connect**" and "**Disconnect**" can be used to manually connect and disconnect the connection.

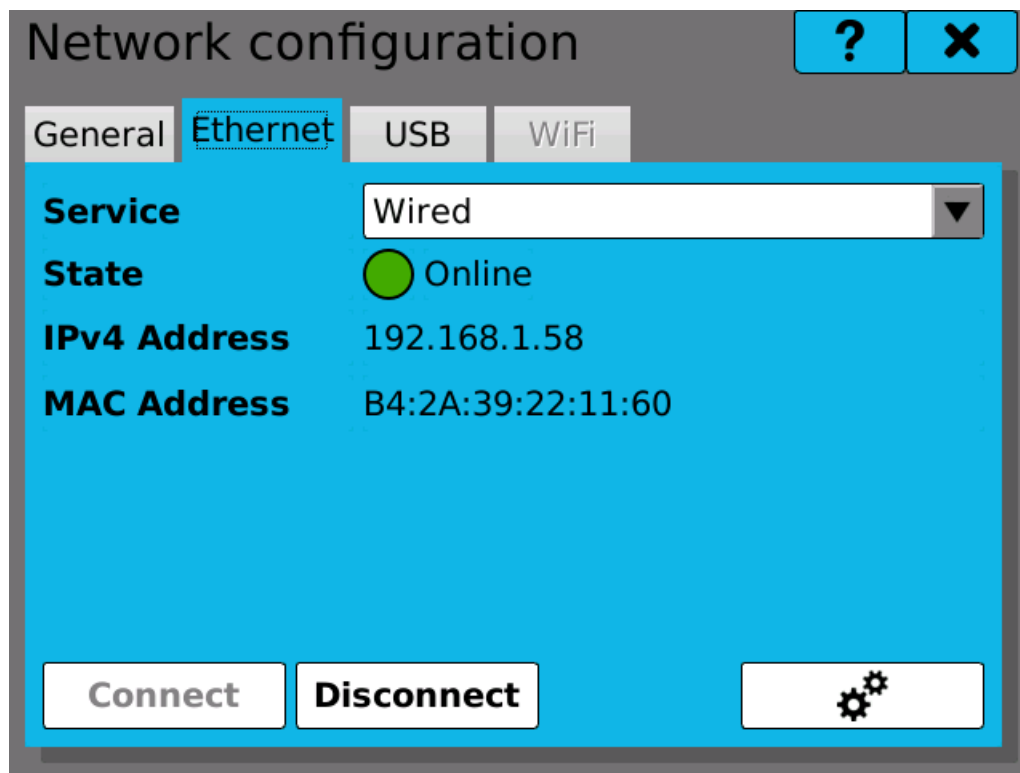

Ethernet connection

Service configuration ? ×

Common IPv4

Name	Wired
Type	ethernet
Autoconnect	<input checked="" type="checkbox"/>

Service configuration

Service configuration ? ×

Common IPv4

Method	Manual ▼
IP Address	10.81.67.175
Netmask	255.255.255.0
Gateway	

IPv4 configuration

21.2 USB Ethernet

Configuration of the USB Ethernet connection is very similar to the Ethernet connection.

Note: to establish communication with a computer over USB Ethernet, proper drivers have to be installed. These drivers should be a standard operation system component and are not supplied with this device.

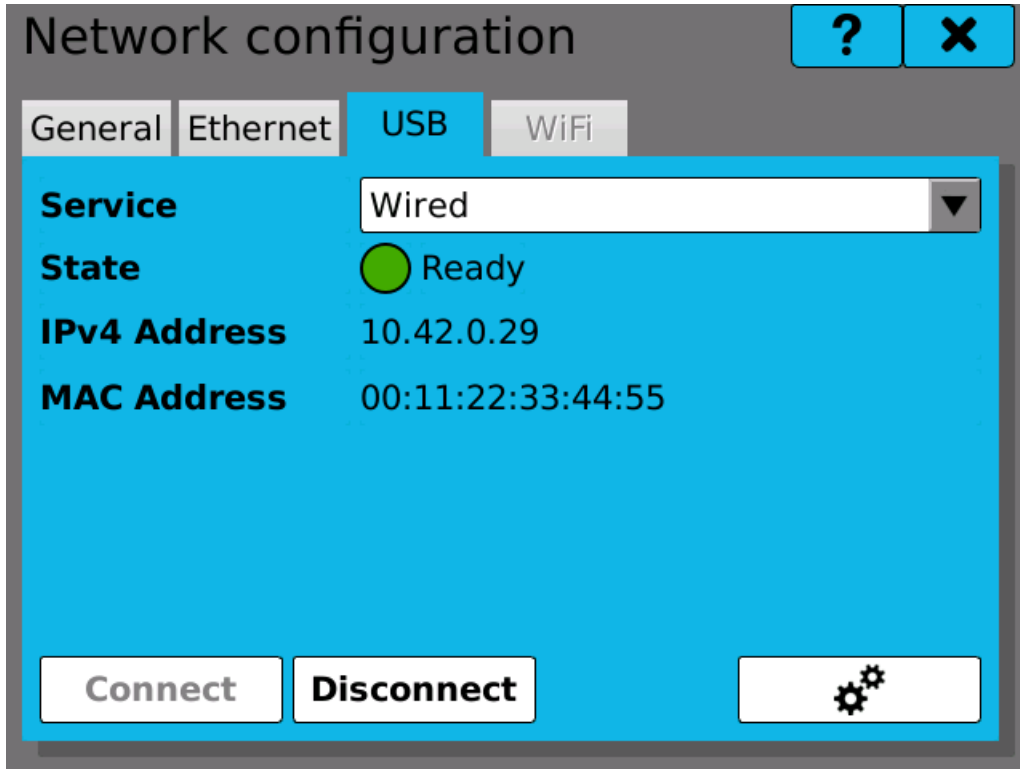

USB Ethernet connection

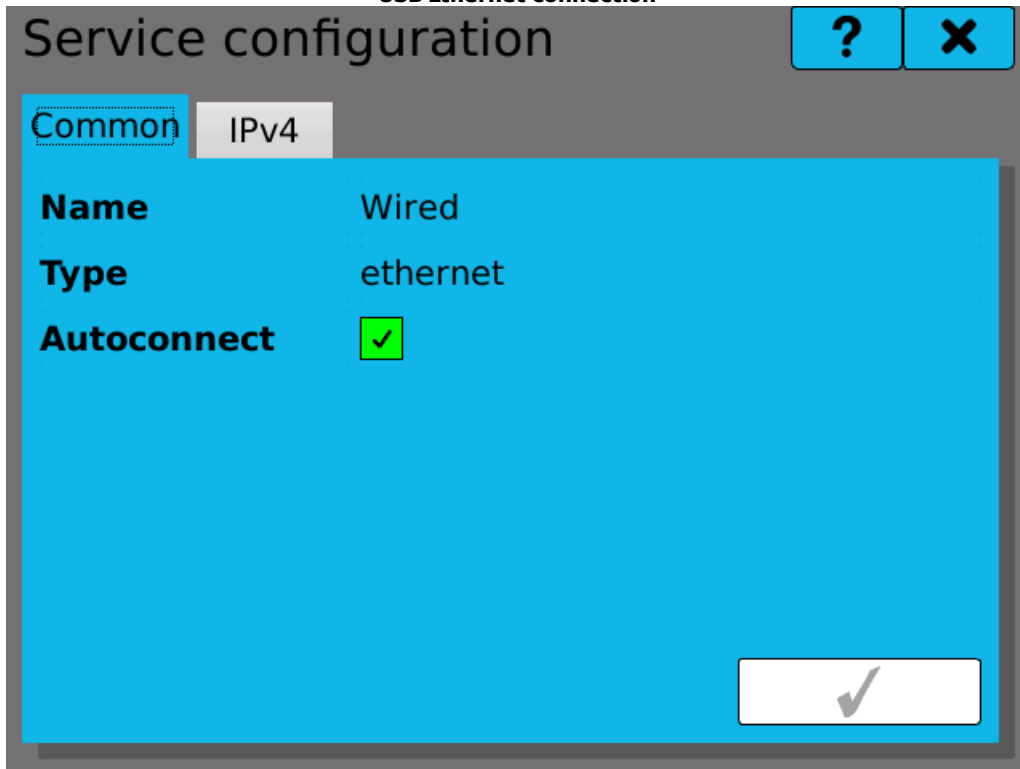

Service configuration

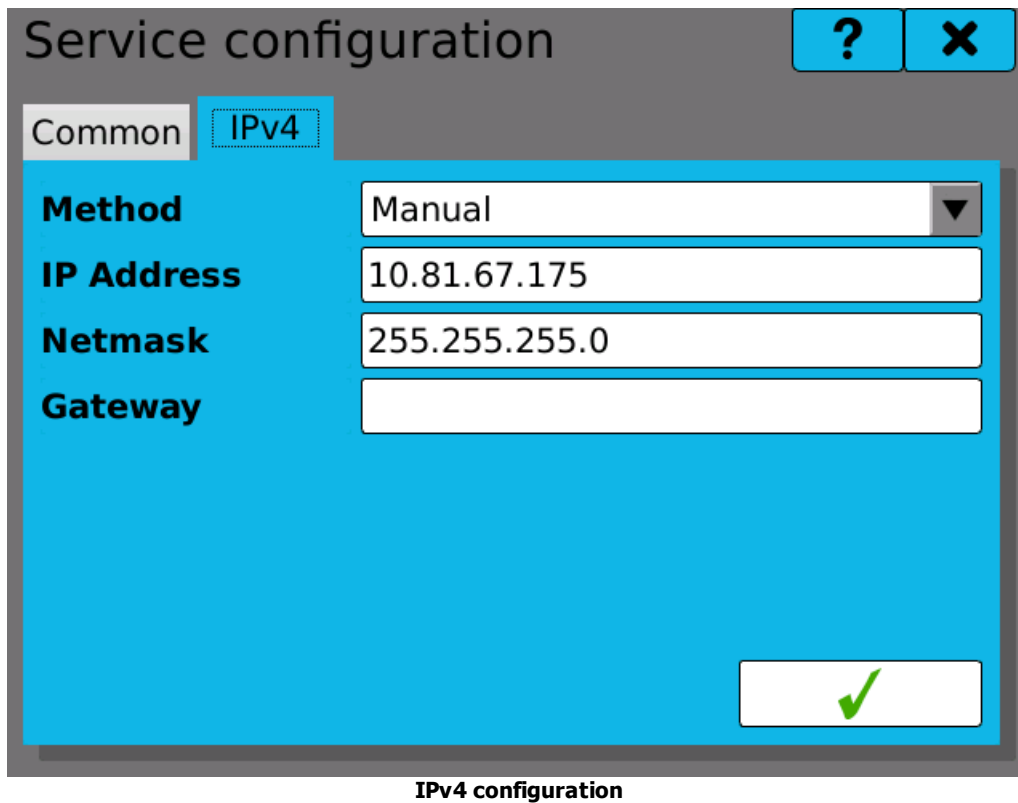

Service configuration

Common IPv4

Method Manual

IP Address 10.81.67.175

Netmask 255.255.255.0

Gateway

✓

IPv4 configuration

21.3 WiFi

Wireless WiFi connection will be available for devices with a WiFi module installed.

22 Startup

This module controls device's behavior on start-up.

Recording behavior selection.

Turn off - recording is always off after start-up.

Continue - the recording returns to the state before shutdown. If recording was running, it will be started again. If not, recording won't start.

Turn on - recording is always turned on after start-up.

Node calculation behavior.

Works on the same principle as recording behavior.

Default screen on startup.

It is possible to either select "**Last viewed**" to display the same screen on start-up as displayed on shutdown or select one screen from the list.

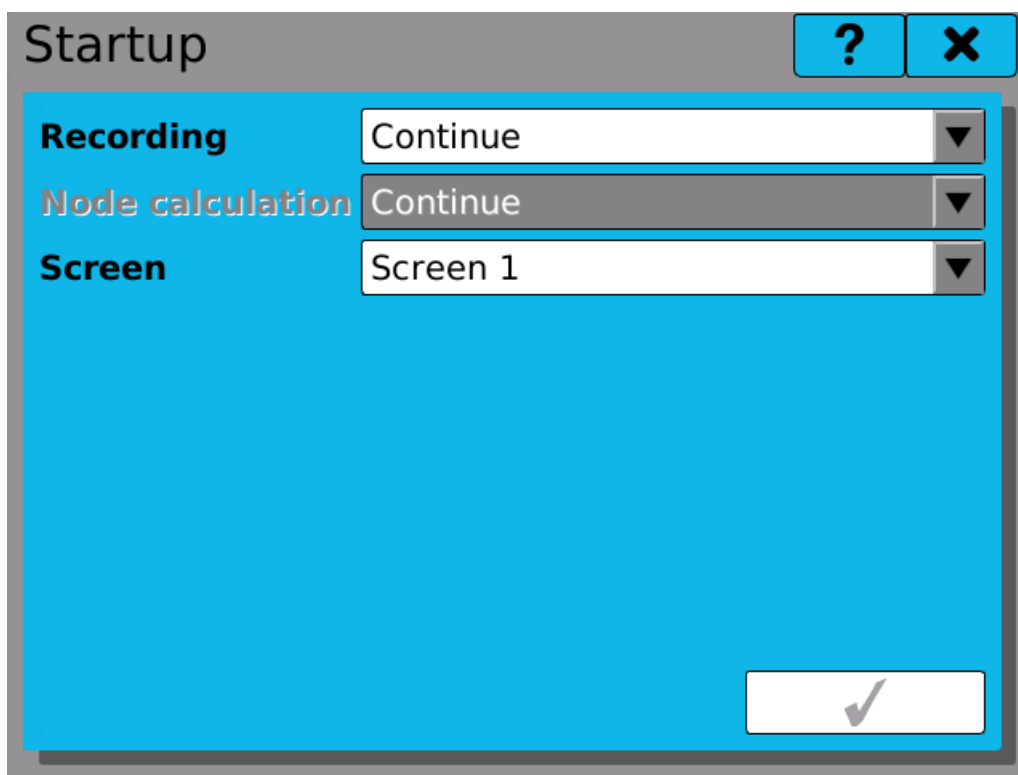

The image shows a dialog box titled "Startup" with a blue background. In the top right corner, there are two buttons: a question mark and a close (X) button. The dialog contains three settings, each with a label and a dropdown menu:

- Recording**: The dropdown menu is set to "Continue".
- Node calculation**: The dropdown menu is set to "Continue".
- Screen**: The dropdown menu is set to "Screen 1".

In the bottom right corner of the dialog, there is a button with a checkmark icon, indicating that the settings can be confirmed.

Startup settings

23 I/O Card calibration

Tool for custom user I/O card calibration.

Position	Position of currently selected card. Buttons ◀ ▶ can be used to look through the installed I/O cards (only currently available cards will be shown).
Card type	Selected card's type description.
Channel	Index of currently selected card channel. Select the desired channel by using the ◀◀ ◀ ▶ ▶▶ buttons.
Range	The range option shows all the available value ranges for the selected channel. Each range has to be calibrated separately.
Offset	Offset value, calculated during the calibration. Offset shows the difference between the real and measured zero value. Ideally, this value is zero. This value is displayed in the selected range's units.
Scale	Scale value, calculated during the calibration. Ideally, this value is one. The value is a real number close to one.
Value	Currently measured value.

Cal. Min - calibrates the minimum value of the selected range.

Cal. Max - calibrates the maximum value of the selected range.

Store - saves the measured calibration values. **WARNING: we recommend to store calibration values after completing the I/O card calibration.**

Restore - restores the previous calibration.

Restore factory calibration - restores factory calibration values. These values cannot be erased or modified.

Calibration procedure:

1. Select the card you wish to calibrate.
2. Select the desired channel.
3. Select the appropriate range.
4. The current calibration values and measured value are shown.
5. Proceed with the minimum value (offset) calibration by applying the precise range's minimum value to the card's input and press the "**Cal. Min**" button.
6. Now apply the precise range's maximum value to the input and press the "**Cal. Max**" button to calibrate the scale. **Warning: it is not possible to calibrate the scale without calibrating the offset first.**
7. Continue with calibration of all needed ranges and channels of the I/O card.
8. After successfully finishing calibrations, save the measured values by clicking on "**Store**".

Card calibration ? X

Position	<input type="button" value="◀"/> <input type="button" value="B3"/> <input type="button" value="▶"/>
Card Type	IN.6 (12 current inputs)
Channel	<input type="button" value="◀◀"/> <input type="button" value="◀"/> <input type="button" value="1"/> <input type="button" value="▶"/> <input type="button" value="▶▶"/>
Range	Current 0 .. 5mA ▾
Offset	<input type="text" value="0.13344"/>
Scale	<input type="text" value="0.97429"/>
Value	<input type="text" value="-0.00023"/>

I/O card calibration

24 Rescue mode

Principle of operation

In case of problems with the device's functionality caused by incorrect configuration, it is possible to start the device in Rescue mode and proceed with necessary fixes. The Rescue mode loads only user profile configuration and can be used to delete configuration part by part or all at once and restore the device to factory settings. Also it is possible to apply software updates.

Switching to Rescue mode

To switch to the Rescue mode, hold both user buttons on start-up for the whole duration of system boot. If the control panel turns red, the switch was successful.

Note: because in the Rescue mode the user interface and graphics settings are not loaded, the main window will show only blank workspace and the device's menu will be in English.

Restoring device functionality

Before proceeding any further, it is advisable to backup you current configuration on a Flash drive or SD card. Then you can use the Configuration manager to restore older configuration. If it is not available, the best way to proceed is to delete that part of configuration, which has been modified most recently and thus is the most probable cause of issues. If this step doesn't work, it is possible to continue deleting other parts of configuration until the issues disappear.

Another way to solve the issues is to update device software to the latest available version, which might already contain a solution to the problem.

If none of these steps lead solve the issues, it is necessary to contact the customer support and have the last used configuration package at hand.

Switching back to normal mode

After proceeding with the steps above the device must be returned back to normal state. Press the reset button (RST) on the front panel and wait until the device reboots (without pressing any buttons).

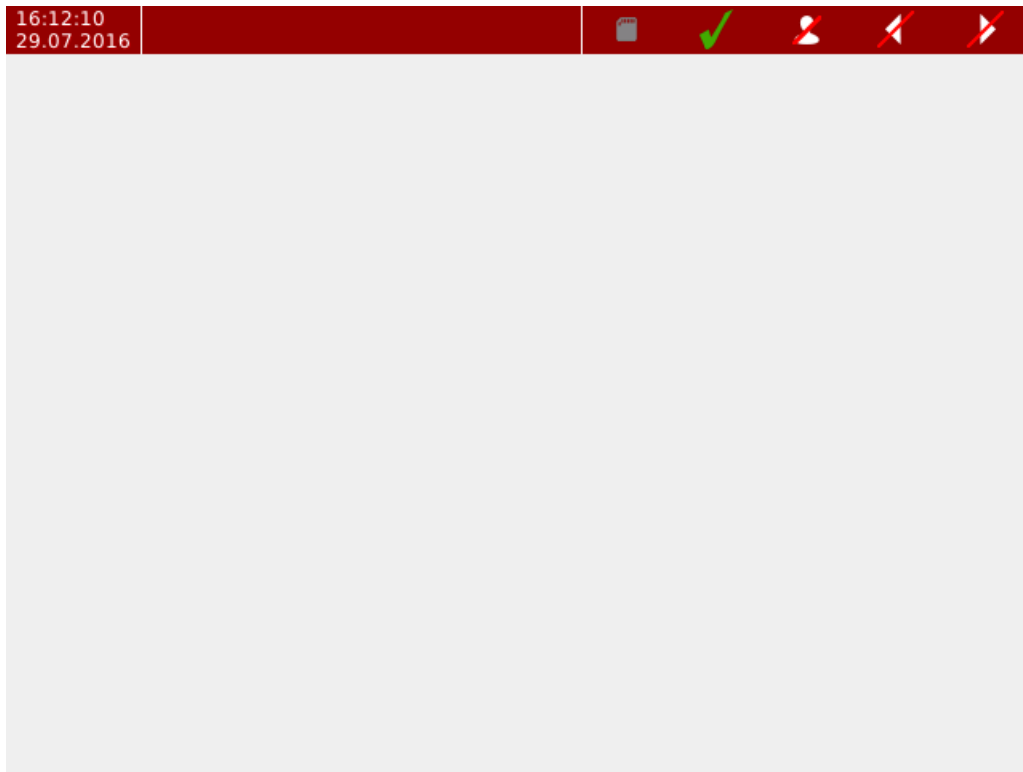

Main screen in Rescue mode

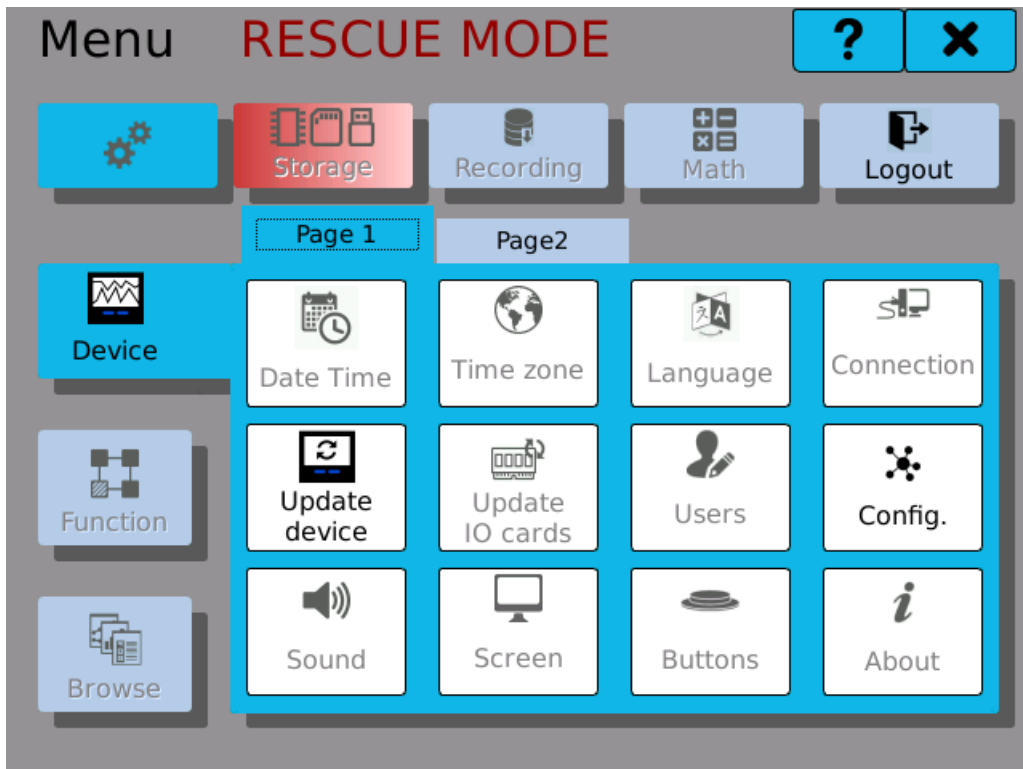

Device Menu in Rescue mode

25 Examples

This chapter lists several typical use-case configuration examples.

Voltage measurement with IN.1 card	Simple example voltage measurement on IN.1 card's input.
Controlling a relay with a comparator	Switching relay contacts based on input voltage value.
Recording measured values	Configuring a recording profile to store measured values.
Recording on button click	Using events to start and stop recording on condition.
Reading voltage through Modbus TCP	Reading current measured voltage through a network from OMR 700 acting as a Modbus TCP slave.

25.1 Example 2: Voltage measurement with IN.1 card

A simple example to show how to measure voltage using IN.1 card and display the measured value on the screen.

1. After logging into the device it is necessary to configure IO card input first. Configuration dialogue can be found in the main menu, tab Function -> Inputs Outputs.

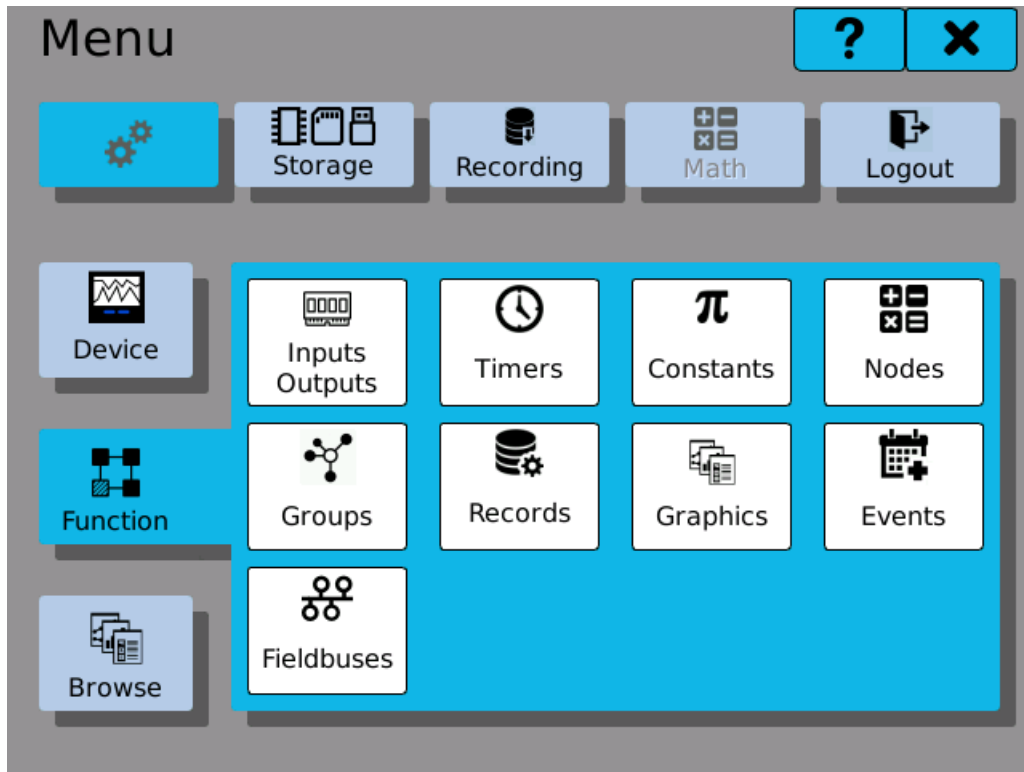

Function Menu

2. In the configuration dialogue, select required IO card and input that we wish to configure.

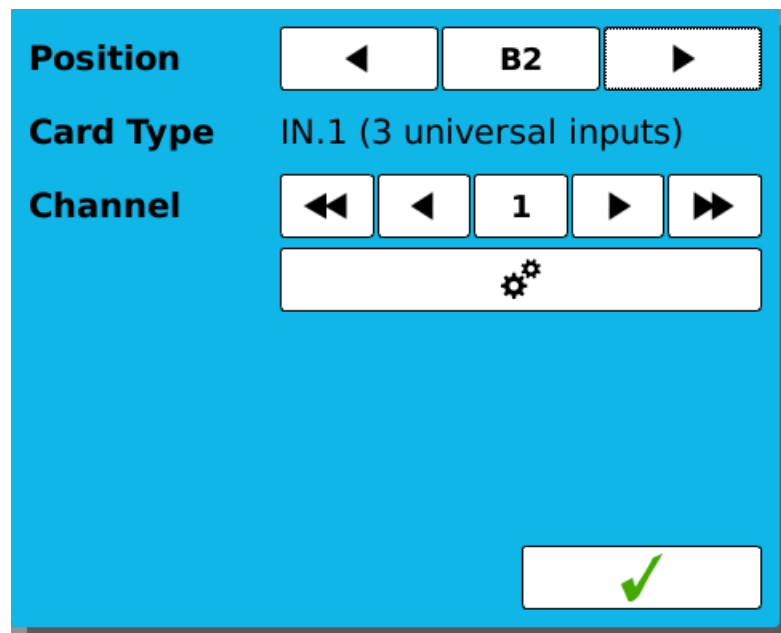

Selecting the card and input channel

3. By clicking on the button  the input configuration button opens. At first we select the type of input.

[B2]IN.1 (3 universal inputs) -> Input: 1 ? ×

Type	Process monitor
Range	
Filter selection	No filter
Filter constant	0.000
Sample rate [Hz]	
Minimum physical value	0.000
Maximum physical value	0.000
Tare	0.000

✓

Input type configuration

4. After selecting "Process monitor", click on the button on the bottom-right side of the dialogue.
5. Now open the dialogue again and select measurement range. Here we use the range of -10 V .. 10 V.

[B2]IN.1 (3 universal inputs) -> Input: 1 ? ×

Type	Process monitor
Range	-10V .. 10V
Filter selection	No filter
Filter constant	0.000
Sample rate [Hz]	
Minimum physical value	0.000
Maximum physical value	0.000
Tare	0.000

✓

Input range selection

6. For simplification we will configure only the basic parameters, sample rate and physical value range. Sample rate sets how many times per second will the card read the input and evaluate the value. Physical value range is used to convert input value. (It can be used if the input voltage represents another physical property). However here we will show input voltage directly. Physical value range is thus equal to the input value range.

[B2]IN.1 (3 universal inputs) -> Input: 1	
Type	Process monitor
Range	-10V .. 10V
Filter selection	No filter
Filter constant	0.000
Sample rate [Hz]	80
Minimum physical value	-10
Maximum physical value	10
Tare	0.000

Complete IO card's input configuration

7. Now we can take a look into diagnostics and make sure everything is configured properly. The field "Physical value" should show the voltage on card's input in Volts.

IN.1 (3 universal inputs)	
Maximum physical value 1	0.000
Maximum physical value 2	0.000
Tare 0	0.000
Tare 1	0.000
Tare 2	0.000
Physical value A 0	8.112
Physical value A 1	0.000
Physical value A 2	0.000
Physical value B 0	0.000

IO Card's diagnostics - configuration check

8. The next step is to process input value using a node. Before configuring it, we have to create a Timer. This timer will decide how often will the new node read value from input and further process it. New timer can be created in a dialogue again accessible through "Function" tab in the main menu.
9. The new timer has to be given a name and a desired period.

Timer	◀◀ ◀ 0 ▶ ▶▶
Name	100 ms
Period	100
Units	ms ▼
✓	

Creating a new Timer

10. Now it's time to create a new node. Enter the configuration window through Menu -> Function. Give the new node a proper name, select previously created timer and set

the "History" value. This value sets how many previous value samples should be stored in memory. In this case it is not important, we can choose for example 1000 samples. Next, since the node is supposed to read values from IO input, select the function "IO Buffer" and save the configuration using the button on the bottom-right side.

Creating a new Node

11. By saving configuration, the button to enter IO buffer settings becomes available. Click it. In the new window select desired input and save by pressing the button on the bottom-right side again.

Selecting IO input as Node's input

12. Now the value indicator on the bottom-left side of node configuration window should show current voltage on selected input in Volts.

The screenshot shows a configuration window with a blue background. The fields are as follows:

- Node:** Navigation buttons (left, right, 0, left, right) and a value of 0.
- Name:** Text input field containing "Voltage".
- Unit:** A greyed-out text field and a gear icon.
- Alias:** Text input field (max. 4 chars).
- Timer:** Text input field containing "100 ms" and a dropdown arrow.
- History:** Text input field containing "1000".
- Function:** Dropdown menu showing "IO buffer" and a gear icon.
- Outputs Limits:** A gear icon.
- Value Indicator:** "8.476" on the left and a checkmark button on the right.

Displaying the current Node value

13. Now comes the time to show the measured value on the screen. Once again, open the "Function" tab in the main menu and click the "Graphics" tile. You will see the graphics configuration window. Select a name for a new screen, save it and click on the configuration button.

The screenshot shows a configuration window with a blue background. The fields are as follows:

- Screen:** Navigation buttons (left, right, 0, left, right) and a value of 0.
- Name:** Text input field containing "Meter".
- Group:** Dropdown menu showing "Without group".
- Grid:** Text input field containing "4/4" and a gear icon.
- Trash:** A trash can icon in a white box.
- Matrix:** A 4x4 grid of white tiles, each containing a red 'X'.
- Checkmark:** A checkmark button at the bottom right.

Configuring a new screen

14. Here you can see the screen matrix. Select area for the new meter. The area can be selected by clicking into the top-left tile of the desired area and to the bottom-right tile

of after. The selected area will be highlighted in red. Now, click the button on the bottom-right corner of the screen to create a new meter.

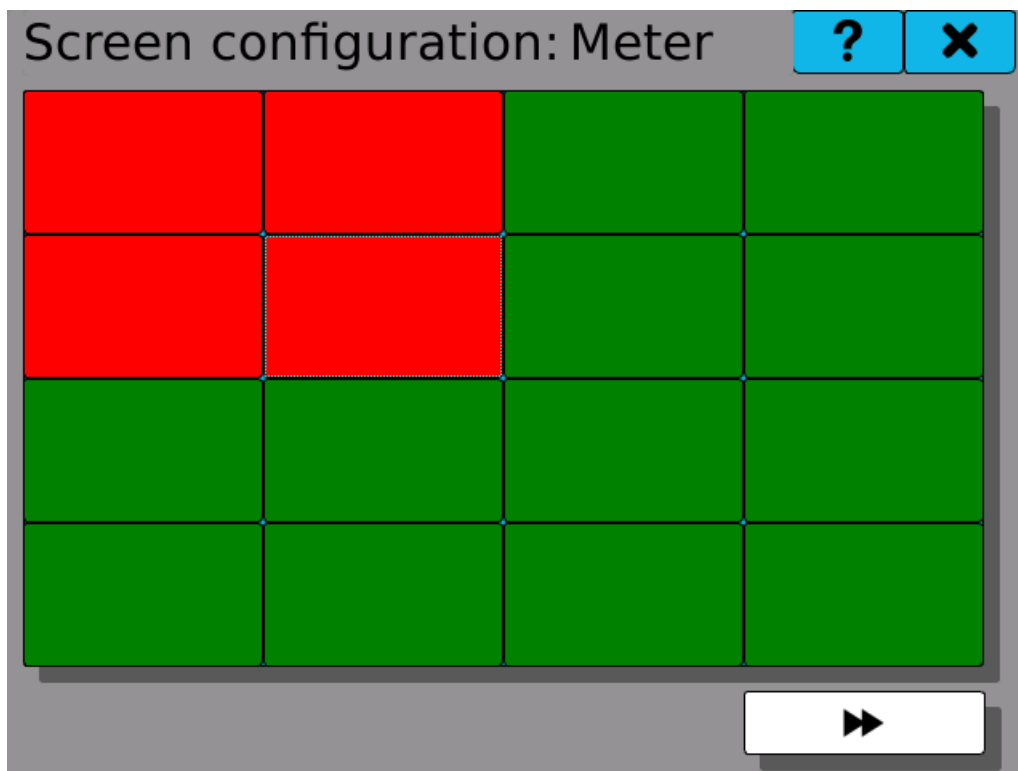

New meter's position and size configuration

15. In the meter configuration dialogue, select desired meter type by clicking on the icon "Type". After choosing the type, enter the Value range and in the "Parameters" configuration click on the first row to assign previously created node.

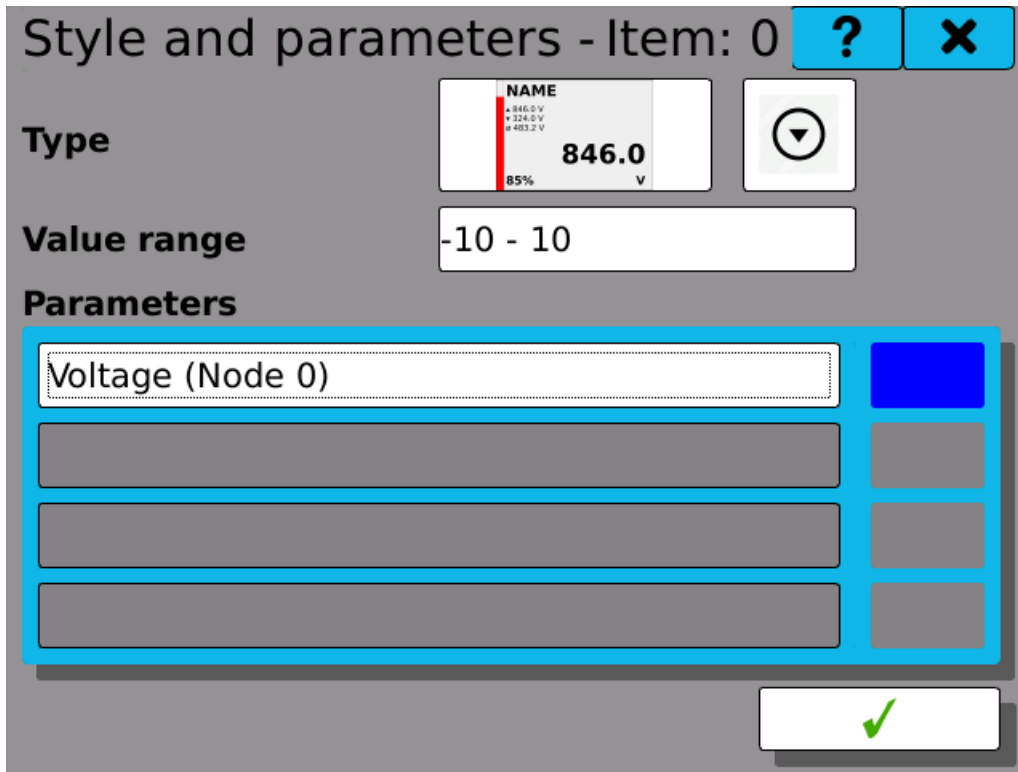

Meter configuration

16. Done! Save the configuration with the button in the bottom-right corner. This will send you back to the screen matrix overview where you can already see the screen preview with an icon of the new meter.

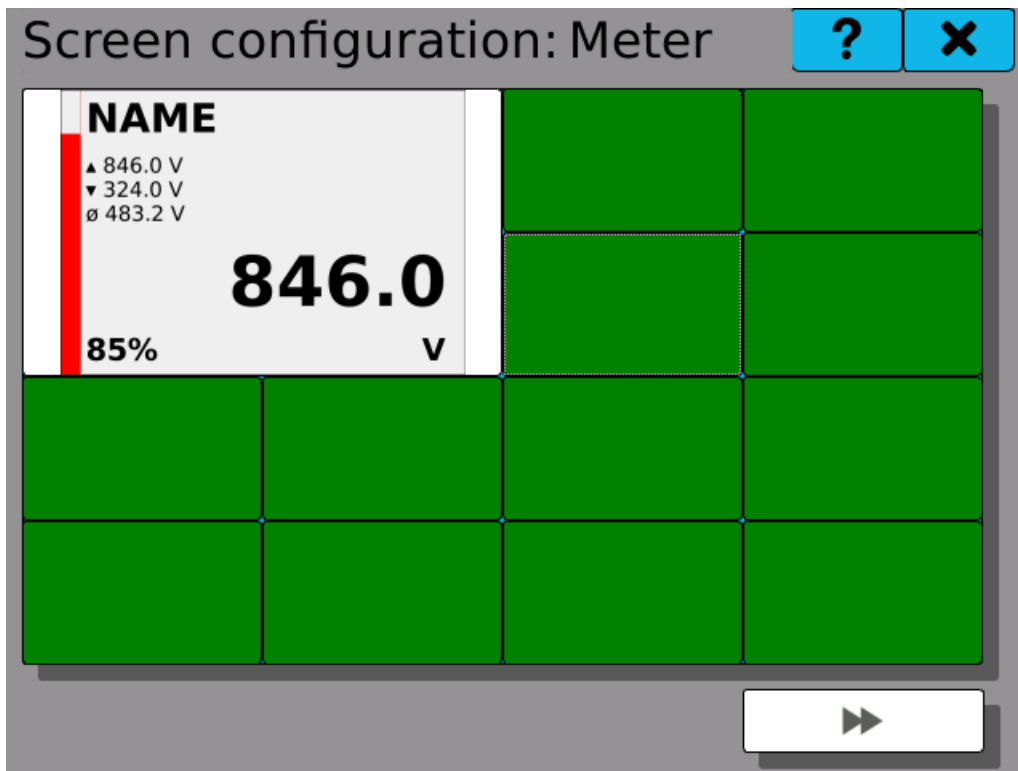

Screen overview with the new meter displayed

- Exit the configuration menu by clicking the close button in the top-right corner of the screen until you reach the main screen. The new meter should be already visible and showing the measured input value.

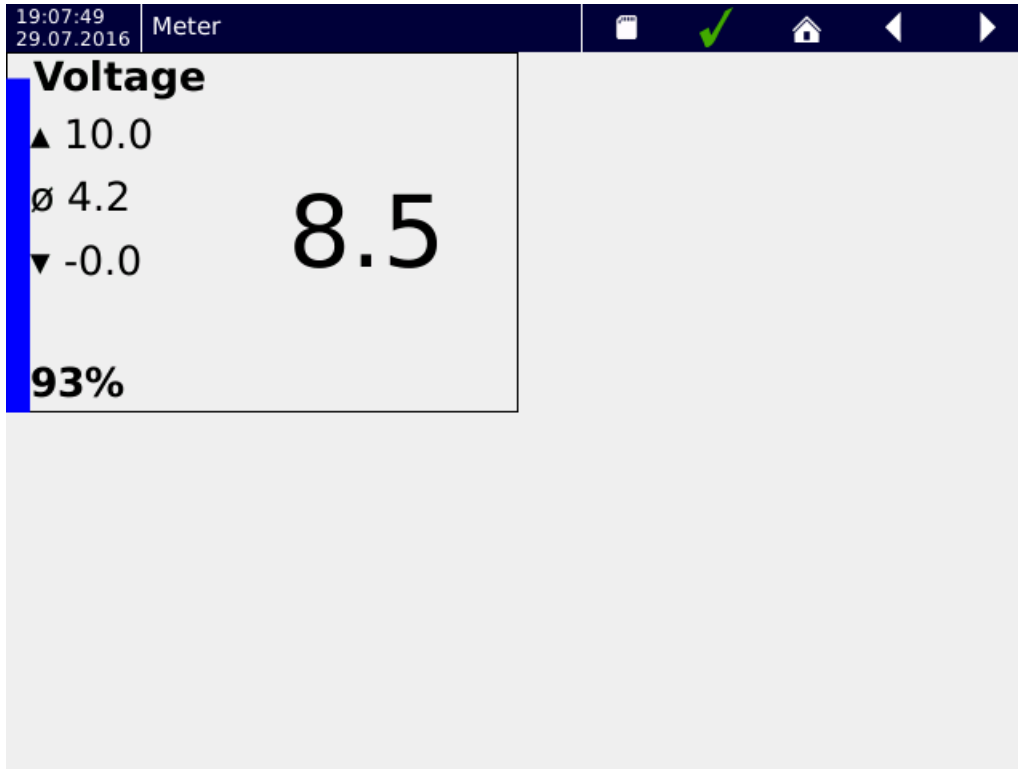

Final look of the meter on the screen

25.2 Example 3: Controlling a relay with a comparator

This example shows a typical situation where we need to switch relay contacts after reaching defined voltage value on input. The input value is taken from node "Voltage", which has been configured in the previous example.

- First we need to specify the limit value of measured voltage as a constant. Configuration of constants can be found in the main Menu -> Functions. Choose any value in the input's measurement range (-10 .. 10 V).

Constant	<input type="button" value="⏪"/> <input type="button" value="⏩"/> <input type="button" value="1"/> <input type="button" value="⏪"/> <input type="button" value="⏩"/>
Name	Limit
Type	Mathematical ▼
Value	8.000
<input type="button" value="✓"/>	

Defining a constant

2. The next step is to create a new node - comparator. It will periodically compare if the measured value is higher than the limit value and set its value according to the result as 0 (false) or 1 (true). We can use the same timer as the measured value's node uses.

Node	<input type="button" value="⏪"/> <input type="button" value="⏩"/> <input type="button" value="2"/> <input type="button" value="⏪"/> <input type="button" value="⏩"/>
Name	Overflow
Unit	<input type="text"/> <input type="button" value="⚙️"/>
Alias	Ovr (max. 4 chars)
Timer	100ms ▼
History	1000
Function	Comparator ▼ <input type="button" value="⚙️"/>
Outputs Limits	<input type="button" value="⚙️"/>
1	<input type="button" value="✓"/>

Creating a new comparator

3. Configuration of comparator inputs can be entered by clicking on the  button, next to the "Function" selector. Here we can choose which values are to be compared. The compare function $f(x)$ specifies the used mathematical operation. For this example we will select (1) \geq (2). This operation sets the node's value as 1 (true) in case that the value (1) is higher or equal to the value (2). If not, the node value is set to 0 (false).

Overflow (Node 2)

f(x) (1) >= (2) ▼

(1)	0.000
(2)	0.000
(3)	Not used
(4)	Not used
(5)	Not used
(6)	Not used
(7)	Not used
(8)	Not used

← ✓

Comparator without any inputs

4. Here we select node "Voltage" as the input value (1) and the previously configured constant "Limit" as a value (2). Store the configuration by clicking on the green tick button.

Overflow (Node 2)

f(x) (1) >= (2) ▼

(1)	Voltage (Node 1)
(2)	Limit (Constant 1)
(3)	Not used
(4)	Not used
(5)	Not used
(6)	Not used
(7)	Not used
(8)	Not used

← ✓

Comparator input configuration finished

5. Now the comparator is properly configured. It's value changes according to the measured input value. The next step is to control relay using this value. Go back to

the "Overflow" node settings and click the  button next to the "Outputs Limits" label.

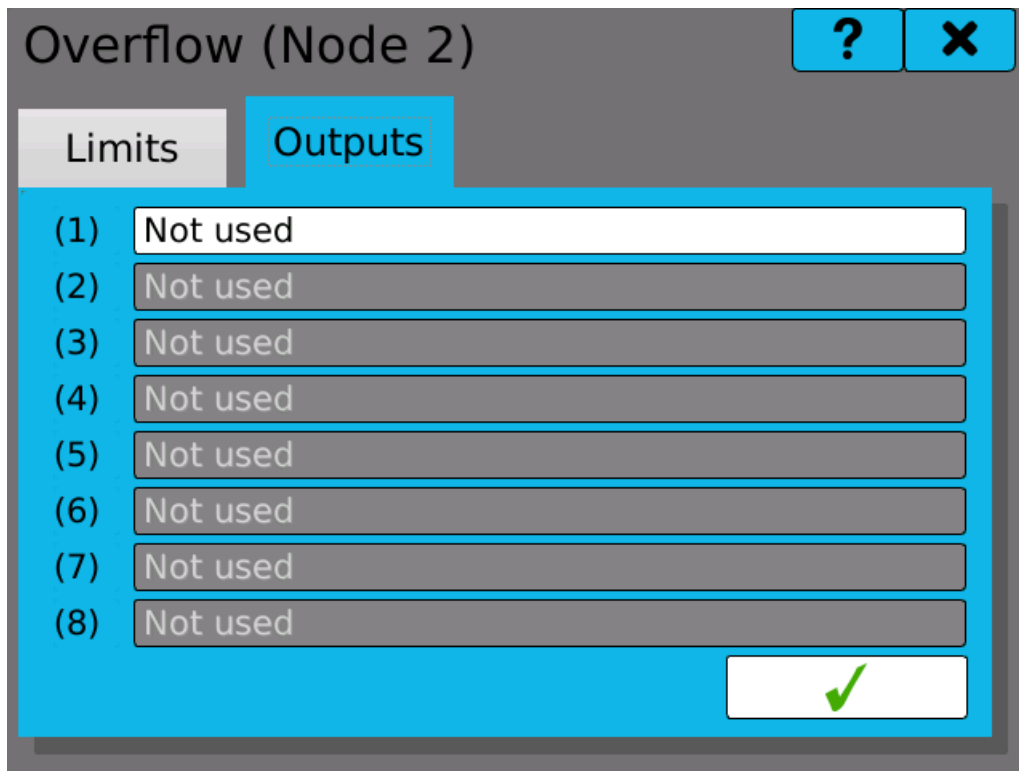

Comparator without any outputs

6. Switch to the "Outputs" card. Here you can choose which relays are going to be controlled by this node. Click on the white button with the label "Not used". In the opened configuration dialogue go to the "IO" tab, select the relay and channel you wish to control and from the "Register" selector choose "Binary value".

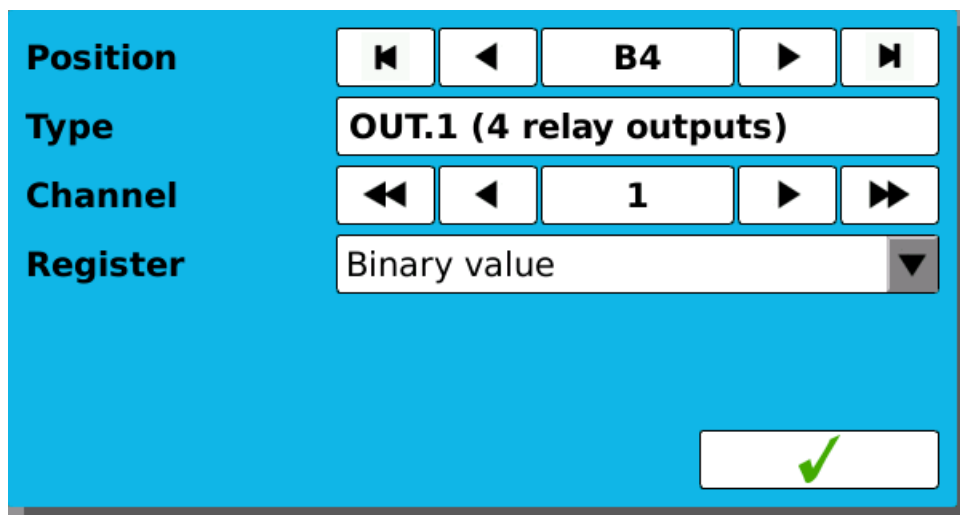

Selecting a relay as an output

7. Done! The relay control is configured and its contacts will switch when an input voltage overflow is detected.

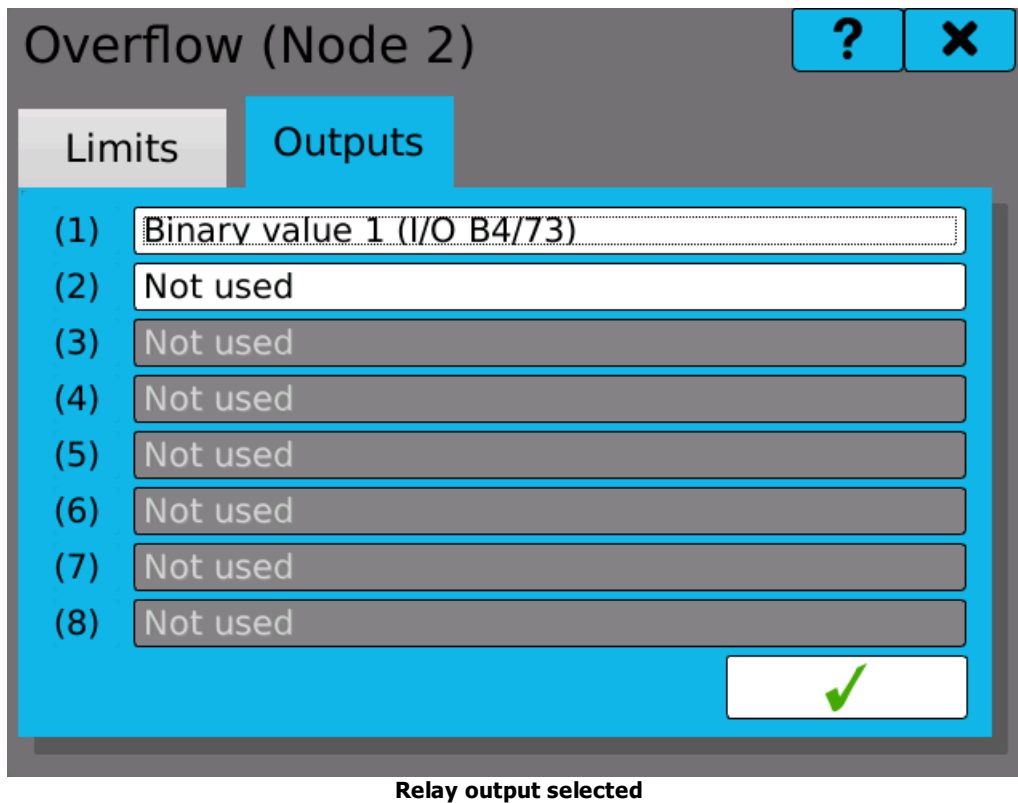

8. Note: it is possible to use several different techniques to display the current state of the relay. If we need to display the limit overflow, it's possible just to create a binary meter on the screen and set it to display the comparator node's value. However, this value does not necessarily have to correspond with the relay's contacts state, for example when the relay is configured as inverting. To display the true state of relay's contacts, set the binary meter to show the relay I/O card channel's register "State".

25.3 Example 4: Recording measured values

Creating a new recording profile to record node values is a matter of few clicks. As a source of values we can use nodes from previous examples.

1. First we start by creating a new recording profile. The profile specifies a group of sources, whose values are going to be recorded. It also sets the sample rate, storage media and other parameters. It is possible to create several profiles and use them at the same time. Configuration window can be opened by clicking the tile "Record" in main Menu -> Function.
2. Set the recording profile a meaningful name. It is possible to optionally set filename for better orientation. Configure the next parameters according to your requirements and then click the  button next to the "Recorded items" label. Groups are not used in this example so we leave the "Without group" option in the selector.

Creating a new recording profile

- Recorded items configuration dialogue gets opened. Here we select which sources we want to record. Add the sources one by one by clicking the "ADD NEW ITEM" button.

Recording profile without any inputs

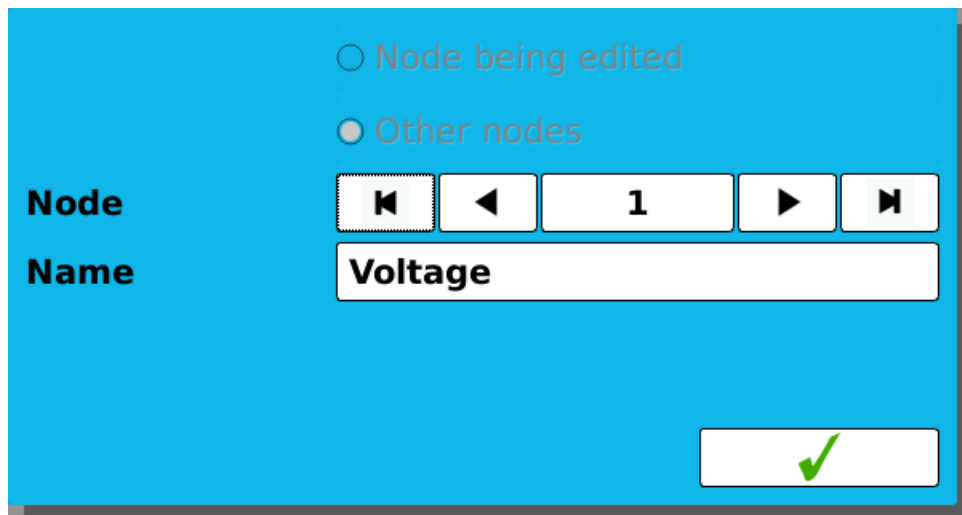

Selecting "Voltage" node for recording

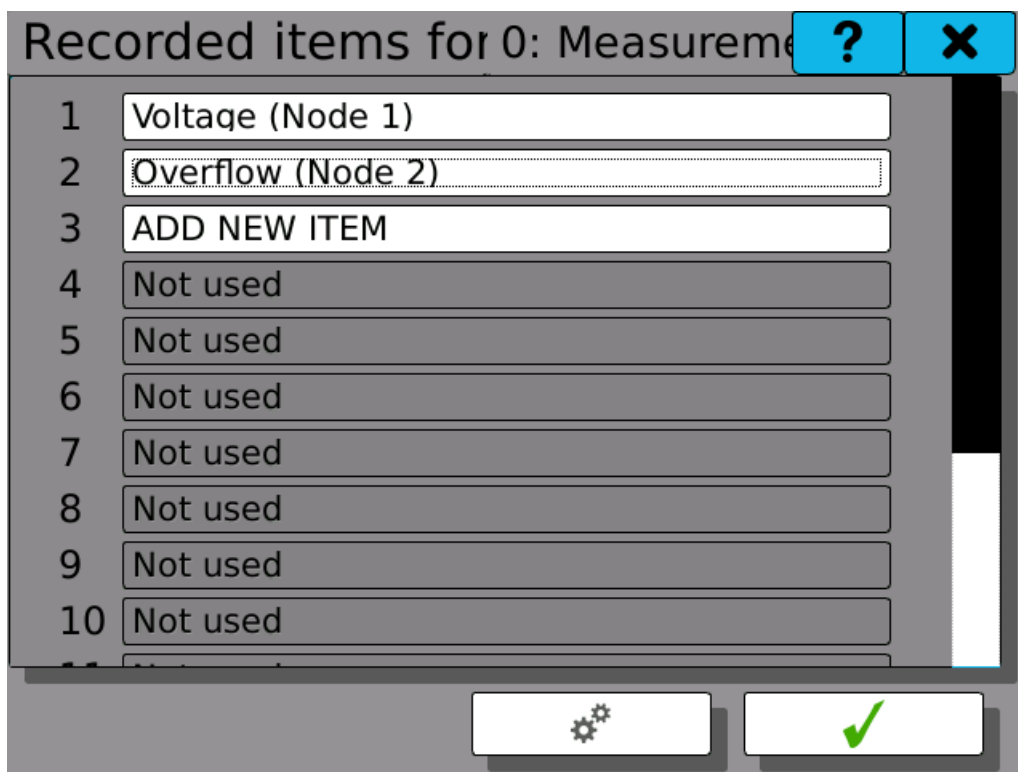

Recording profile items selected

4. Done! Now you can go to the main menu and start recording by clicking the "Recording" button on the top of the screen. The recording starts immediately and the button turns green. The button "Storage" next to it should now show the current state of storage media.

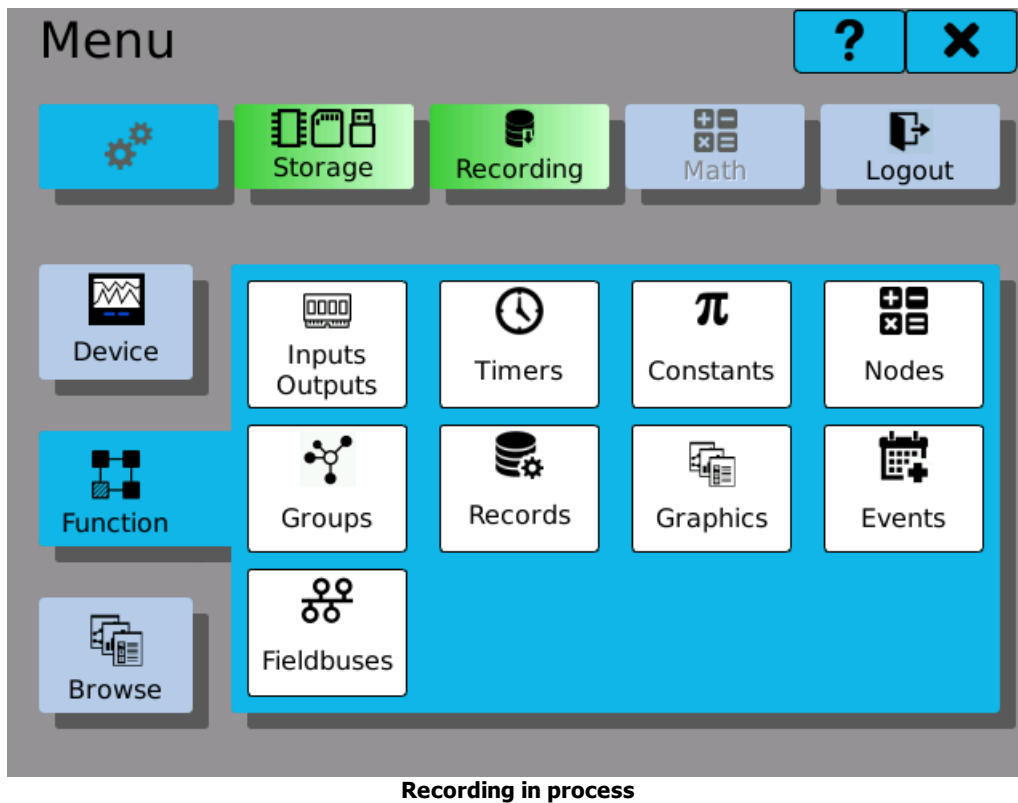

25.4 Example 5: Recording on button click

This example demonstrates how to configure simple event and shows the basic principles of causes and effects.

The default way to start and stop recording is by clicking the "Recording" button in main menu. However, it is also possible to configure events to trigger recording by various other means. In this example we will configure the button 1 to start recording and the button 2 to stop it.

It is necessary to take into consideration that triggering start of recording and stopping recording are two separate actions and thus require two separate events.

1. First step is to create a new event and assign a name. Configuration must be saved in order to continue to the next step.

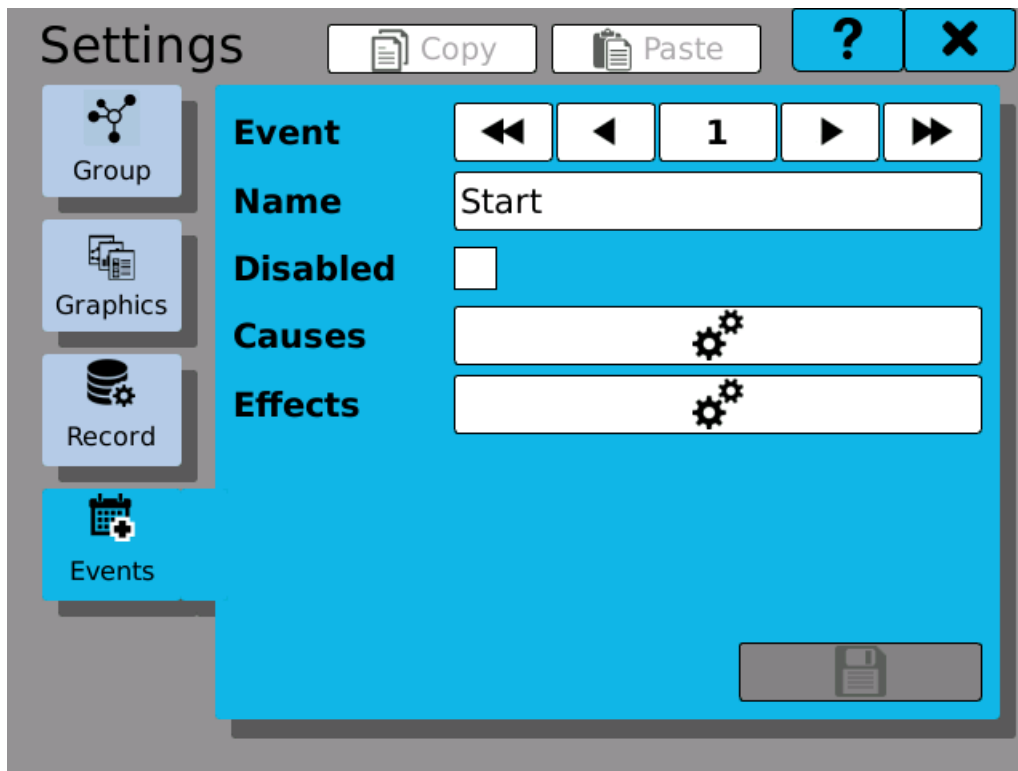

Configuring new event

2. Now we have to configure the cause, that will trigger our new event. After clicking on the configuration button, you will see cause configuration dialog. Select the type "Button" and then choose "Button 1" and action "Clicked". This means that our event "Start" will occur every time the button 1 is clicked (pressed and released shortly after).

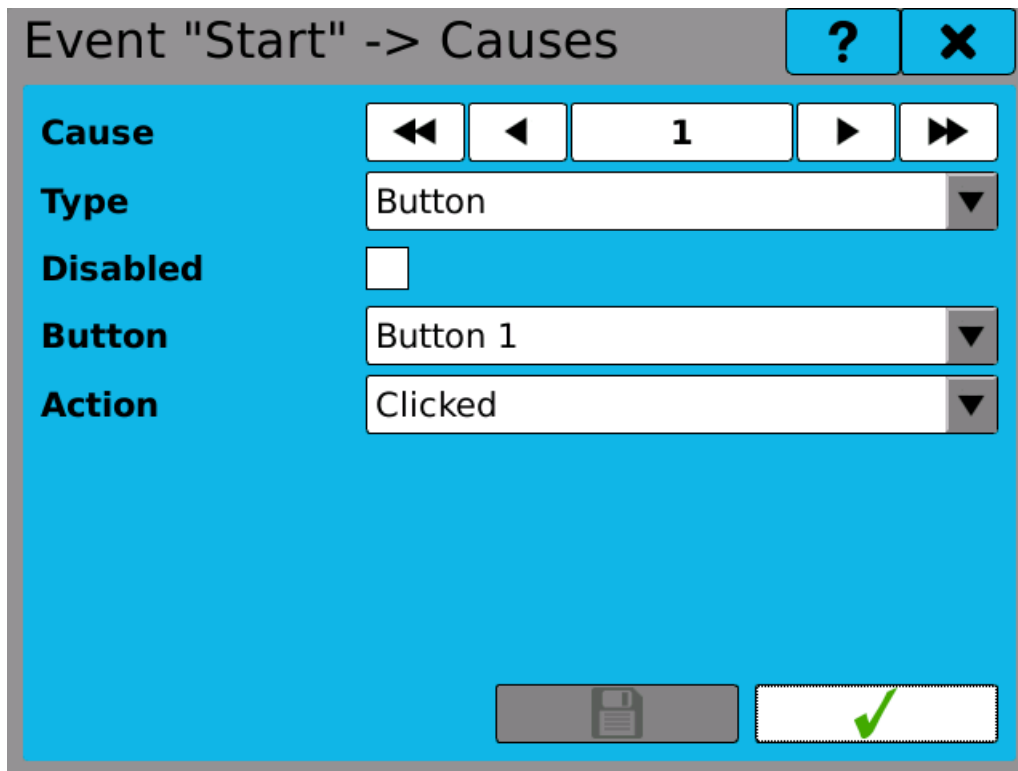

Event "Start" -> Causes

Cause: << < 1 > >>

Type: Button

Disabled:

Button: Button 1

Action: Clicked

Buttons: Save, Confirm

Creating new cause

3. After configuring the cause, open the Effects configuration dialogue. Select type "Record" and action "Start". This means every time event occurs, the recording will be started.

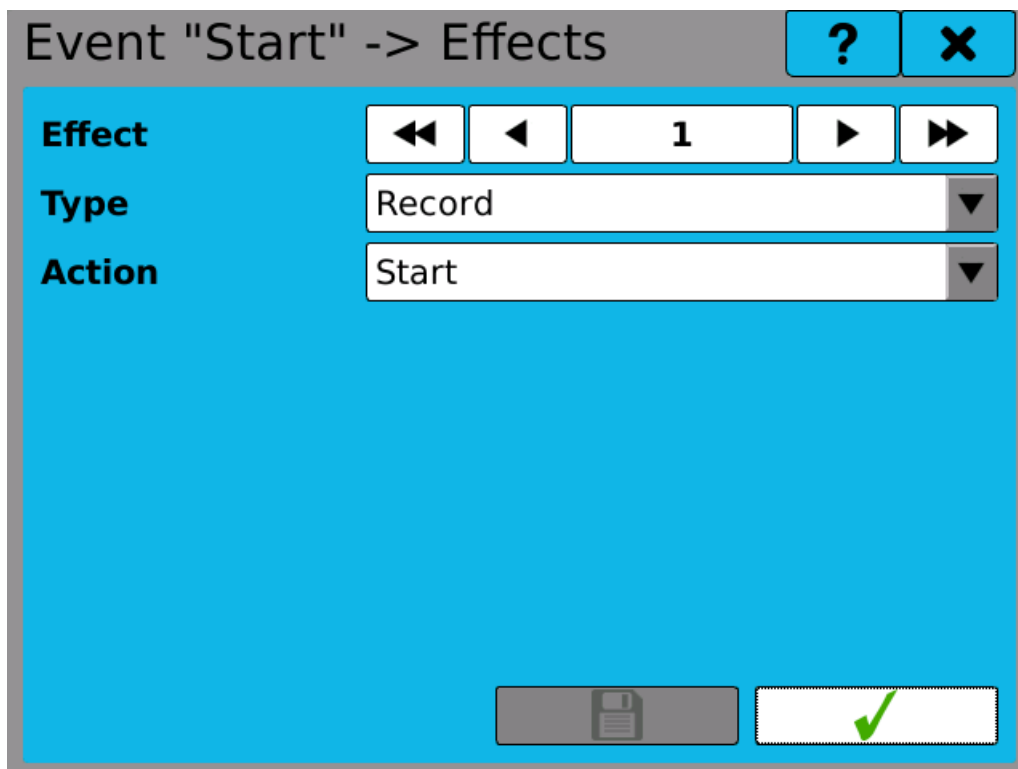

Event "Start" -> Effects

Effect: << < 1 > >>

Type: Record

Action: Start

Buttons: Save, Confirm

Configuring effect

4. Now create second event (in our example called "Stop") with cause type "Button", reacting on button 2 click and having an effect type "Record" with action "Stop".
5. Done! You can now start control recording using user buttons. You can also view event statistics in "Event browser", which can be found in main menu on tab "Browse".

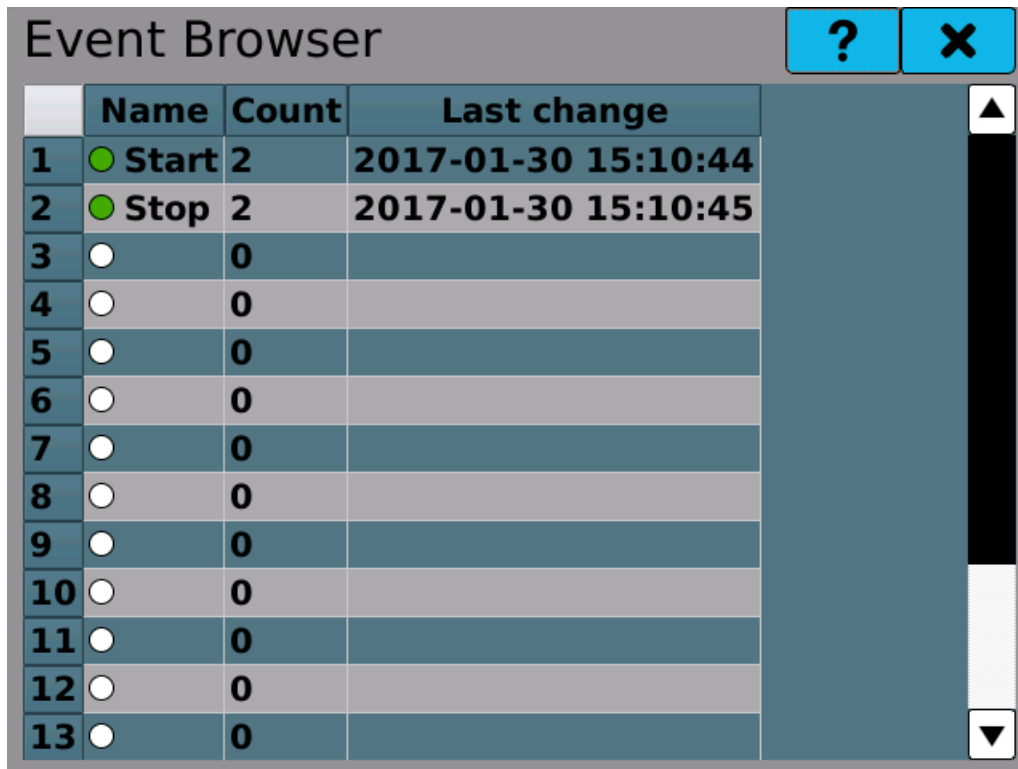

	Name	Count	Last change
1	● Start	2	2017-01-30 15:10:44
2	● Stop	2	2017-01-30 15:10:45
3	○	0	
4	○	0	
5	○	0	
6	○	0	
7	○	0	
8	○	0	
9	○	0	
10	○	0	
11	○	0	
12	○	0	
13	○	0	

Statistics in the Event Browser

25.5 Example 6: Reading voltage through Modbus TCP

Some situations require reading measurements right away from a remote device. In such cases it is possible to use the Fieldbus module. This module allows OMR 700 to function for example as a Modbus TCP slave.

This example shows how to set up the Fieldbus module and read measured voltage remotely over data network.

1. First we need to create a new fieldbus. Go to the "Fieldbuses" configuration window in the Main menu -> Function. Create a new Modbus TCP Slave fieldbus.

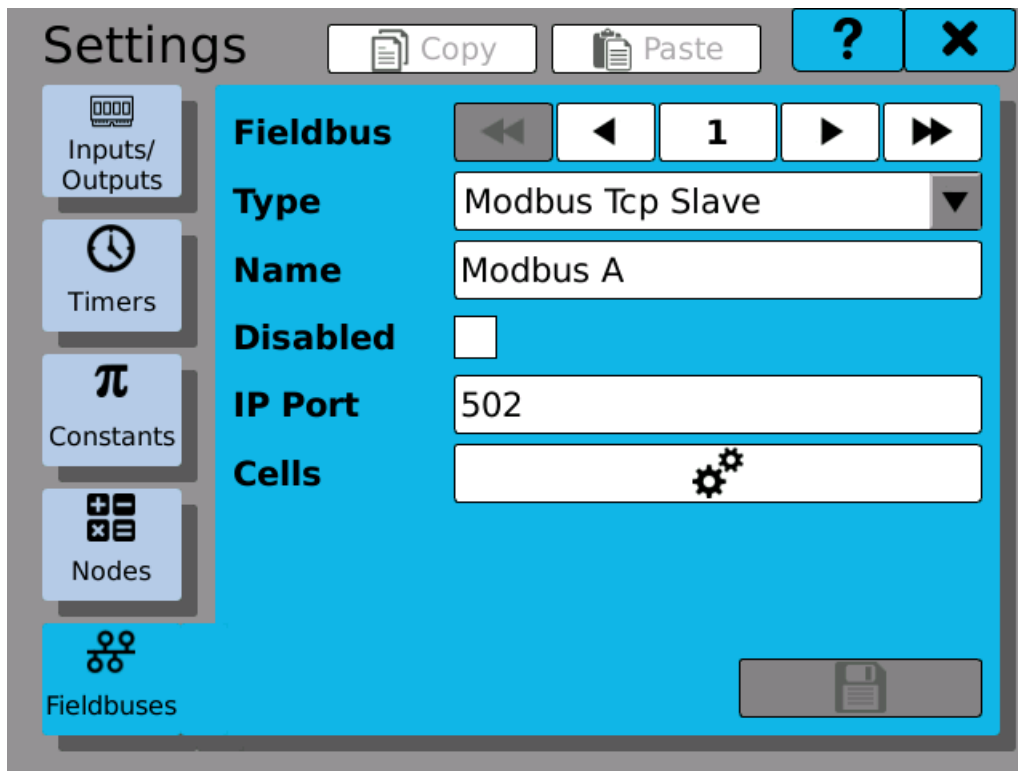

Creating new Modbus TCP type fieldbus

2. Now we need to create a new cell, which will be used for remote access. Since the measured voltage value is a number with floating decimal point, we need to use "Mathematical" value type. Next, select proper access method. Because we only want to read this value remotely, choose "Input register". As the last step, select the address you wish to use. The "Used Addresses" box shows the real address range, which has to be used for reading the value.

Modbus "Modbus A" -> Cells

Cell: 1

Name: Voltage meas.

Disabled:

Value type: Mathematical

Access: Input register

Start Address: 1234

Used Addresses: 1234, 1235

Buttons: Save, Confirm

Configuring new fieldbus cell for remote access

3. The fieldbus module is configured now. As a next step, we have to assign the measured value to the new fieldbus cell. We will use the node "Voltage", defined in previous examples. Go to the node configuration and open the "Outputs / Limits" configuration dialogue. In the "Outputs" tab select the new fieldbus and the "Voltage meas." cell.

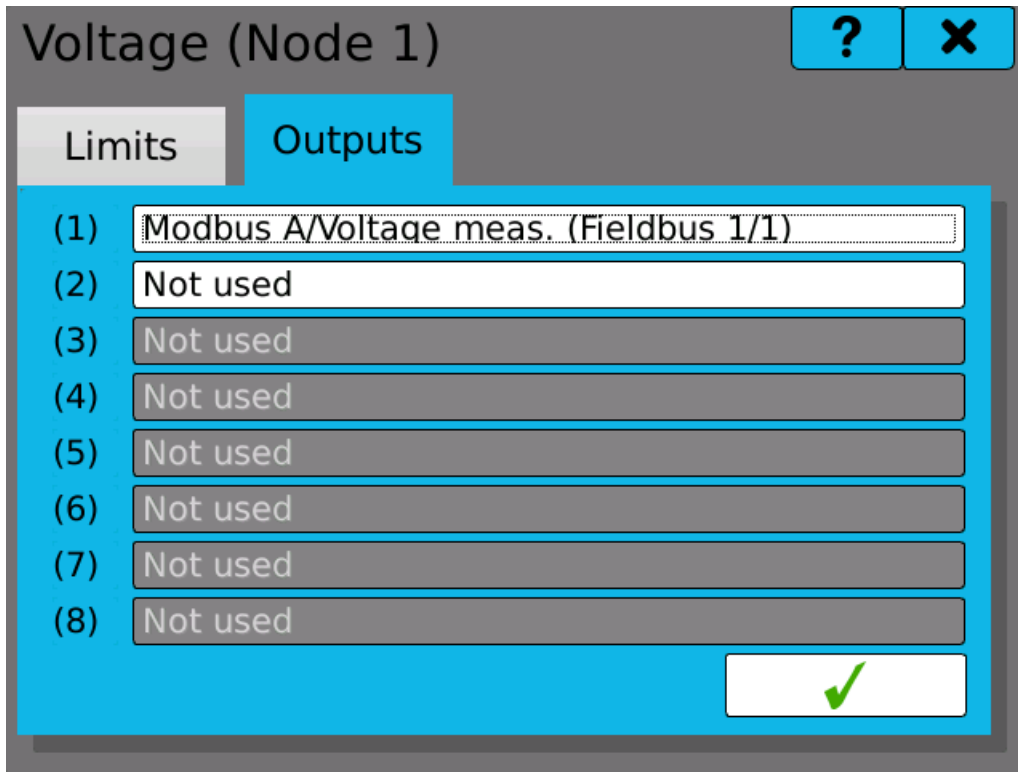

Selecting fieldbus cell as a node output

4. Done! The result can be seen in the Fieldbus browser dialogue and you can use any device acting as a Modbus TCP master to read the measured value.

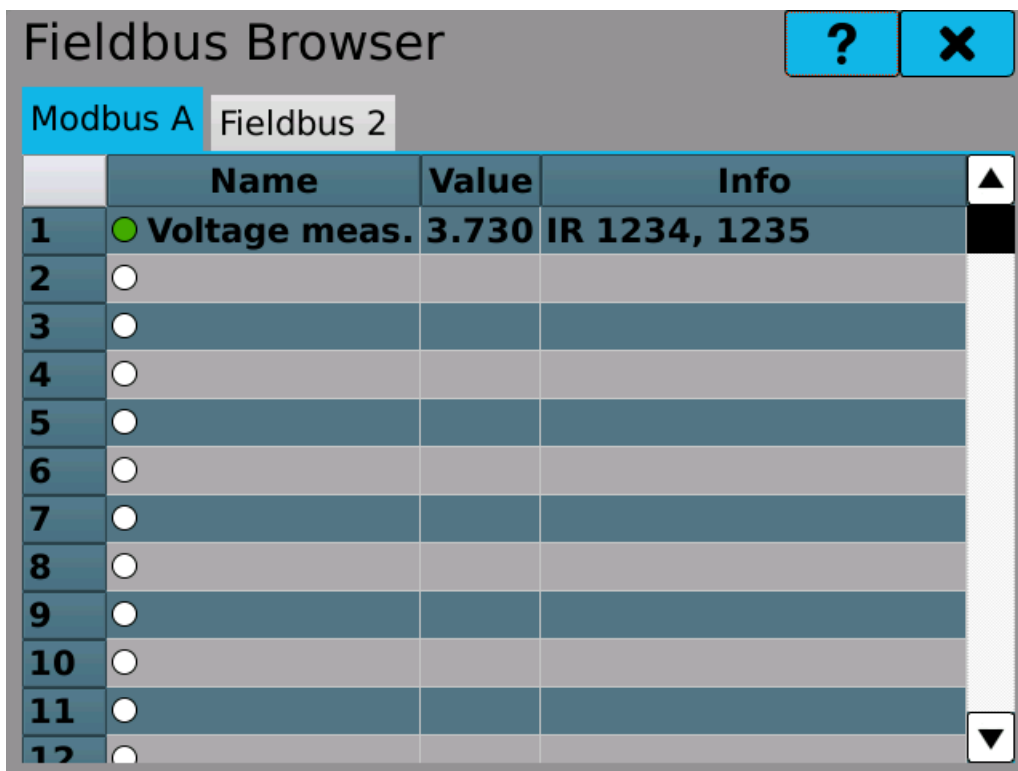

Fieldbus browser with configured voltage measurement cell