

OMX 38

TRANSMITTERS TO DIN RAIL

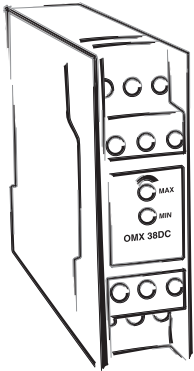

1. DESCRIPTION



DESCRIPTION

The OMX 38 model series are transmitters to DIN rail, which are manufactured in the following alternatives:

OMX 38DC	DC input ⇒ analog output
OMX 38AC	AC input ⇒ analog output
OMX 38W	Power ⇒ analog output
OMX 38RTD	Pt 100 ⇒ analog output
OMX 38DU	Linear poten. ⇒ analog output
OMX 38OHM	Resistance ⇒ analog output

The instrument is based on a simple analog converter, which secures good accuracy and stability. The transmitter is in a plastic DIN box with terminal board to rail of 35 mm in width. Transmitter power supply (230 VAC), input and output signal have galvanic separation with isolation voltage 300 V.

OPERATION

The instrument is designed for simple measurement without further control.

CALIBRATION

Contingent corrections may be performed by a trimmer from the front of the instrument within the range of approx ±2 %.

2. CONNECTION

The lead for feeding the instrument should not be in the proximity of the incoming low-potential signals. Contactors, motors with larger input power and other efficient elements should not be in the proximity of the instrument. The lead into the input of the instrument (the measured quantity) should be in sufficient distance from all power leads and appliances. Provided this cannot be secured it is necessary to use shielded leads with connection to ground. The instruments are tested in compliance with standards for use in industrial area, yet we recommend to abide by the above mentioned principles.

SAFETY INSTRUCTIONS

Please, read the enclosed safety instructions carefully and observe them! These instruments should be safeguarded by isolated or common fuses (breakers) with respect to their real demand! For safety information the EN 61 010-1 + A2 standard must be observed. This instrument is not explosion-safe!

TECHNICAL DATA

Transmitters of the OMX 38 series conform to the European regulation 89/336/EWG and the Ordinance 168/1997 Sb. They are up to the following European and Czech standards:
 EN 55 022, class B
 EN 61000-4-2, -4, -5, -6, -8, -9, -10, -11
 The instrument is applicable for unlimited use in agricultural and industrial areas.

! Grounding on terminal „E“ has to be connected at all times.

OMX 38DC, PM

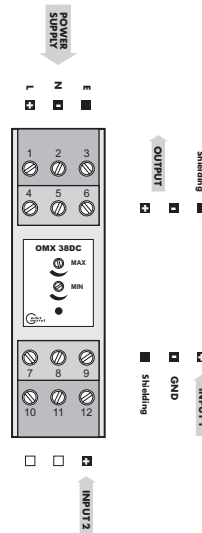

OMX 38AC

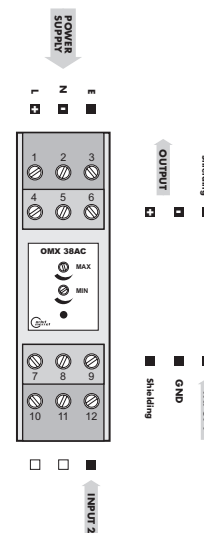

OMX 38RTD, OHM

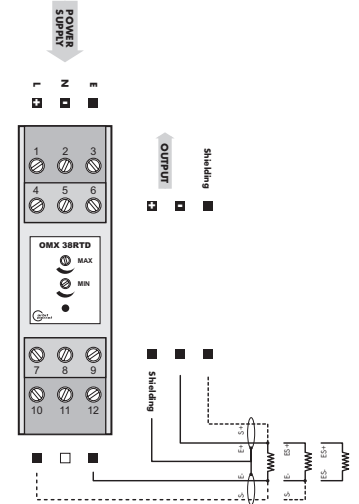

OMX 38W

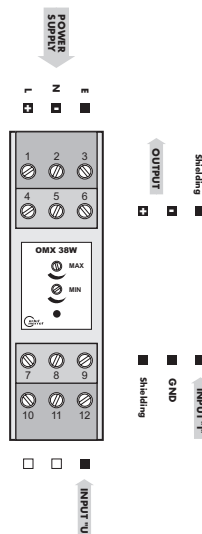

OMX 38DU

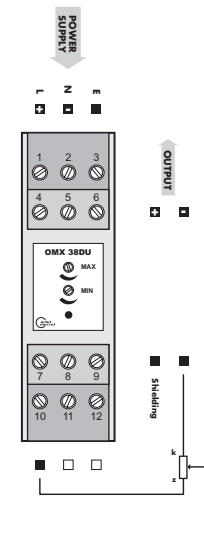

Recommended wiring

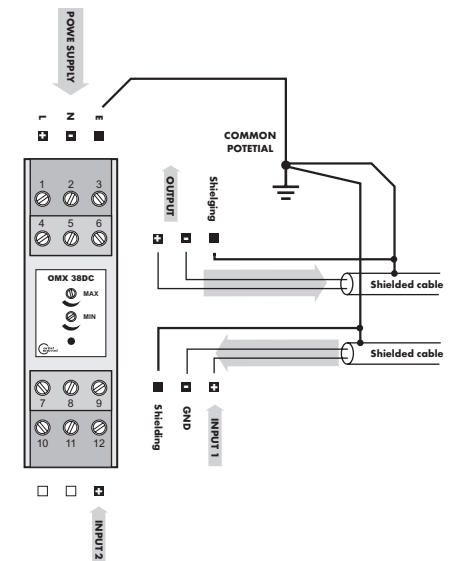

3. TECHNICAL DATA

Measuring range

the range is fixed, according to order			DC
Input:	±10 mV...10 V	0,5 MOhm	Input 2
	±10 V...450 V	1 MOhm	Input 2
	±0...5 A	< 200 mV	Input 1

For larger ranges it is necessary to use external divider or shunt.

the range is fixed, according to order			AC
Input:	60 mV...450 V	1 MOhm	Input 2
	0...5 A	< 400 mV	Input 1
Frequency range:	0...2 500 Hz		

For larger ranges it is necessary to use external divider or shunt.

the range is fixed, according to order			PM
	0...2 V	0,5 MOhm	Input 2
	0...5 V	0,5 MOhm	Input 2
	0...10 V	0,5 MOhm	Input 2
	0...5 mA	< 400 mV	Input 1
	0...20 mA	< 400 mV	Input 1
	4...20 mA	< 400 mV	Input 1

the range is fixed, according to order			W
Input:	0...450 V	1 MOhm	Input U
	0...5 A	< 400 mV	Input 1
Frequency range:	0...600 Hz, upon request 20 000 Hz		

For larger ranges it is necessary to use external divider or shunt.

the range is fixed, according to order			RTD
Range:	-50...850°C		
Type:	Pt 100 - 3 860 ppm/°C		
	Pt 1 000 - 3 860 ppm/°C		
	Ni 1 000 - 5 000 ppm/°C		
Connection:	2, 3 or 4 wire		

the range is fixed, according to order			DU
Lin. potentiometer:	0,5...100 kOhm		
Pot. power supply:	10 V, ±0,2 %		

the range is fixed, according to order			OHM
Input:	0,1...100 kOhm		
Connection:	2, 3 or 4 wire		

Instrument accuracy

Accuracy:	±0,1 % of range	DC
	±0,3 % of range	AC, W
	±0,2 % of range	RTD, OHM
Rate:	continuous measurement	
Overload capacity:	2x (long-term) not for 5 A and 300 V	
Calibration:	at 23°C and 40 % r.h.	

Outputs

Analog:	isolated, fixly preset
TC:	100 ppm/°C
Rate:	response to change of value < 1 ms

DC, PM, DU

Voltage:	response to change of value < 1 s
Current:	0...2 V; 5 V; 10 V, upon request ±10 V (max.load 1 kOhm)
	0/4...20 mA; upon request ±20 mA, 0...5 mA
	- compensation of conduct up to 500 Ohm
Corrugation:	5 mV of residual corrugation upon input signal 10 V

Power supply

24/110/230 VAC, 50/60 Hz, ±10 %, 3 VA
10...30 VDC/max. 150 mA, isolated
- power supply is safeguarded by a fuse inside the instrument

Mechanic properties

Material:	ABS (UL 94-V0), grey
Dimensions:	110,5 x 81,5 x 24,5 mm
Installation:	to DIN rail, width 35 mm

Operating conditions

Connection:	connector terminal board - conductor section up to 2,5 mm ²
Stabilization period:	within 15 minutes after switch-on
Working temperature:	0°...60°C
Storage temperature:	-10°...85°C
Cover:	IP20
Construction:	safety class II
Isolation resistance:	300 V/60 V (AC/DC supply)
El. safety:	EN 61010-1, A2
Overvoltage category:	for pollution degree II II. - instrument power supply (300 V) II. - input, output (300 V)
EMC:	see Declaration of conformity

4. INSTRUMENT DIMENSIONS

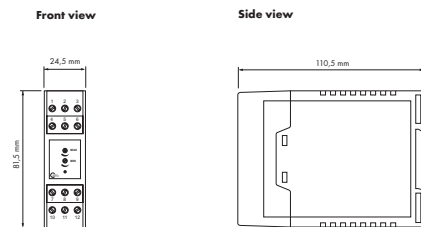

Installation to DIN rail of 35 mm wi

! Upon installation of the transmitter we recommend to secure airflow along the side walls. Do not install transmitters closely to one another.

5. DECLARATION OF CONFORMITY

Company: ORBIT MERRET, spol. s r.o.
Klánova 81/141, 142 00 Prague 4
Czech Republic
IČO: 00551309

Manufacturer: ORBIT MERRET, spol. s r.o.
Vodňanská 675/30, 198 00 Prague 9
Czech Republic

declares at its full responsibility that the product presented hereunder meets all technical requirements, is safe for use when used under the terms and conditions determined by Orbit Merret, spol.s r.o. and that our company has taken all steps to ensure conformity of all products of the type referred-to below, which are being brought out to the market, with technical documentation and requirements of the appurtenant Ordinance.

Product: Analog transmitter
Model: OMX 38
Version: DC, PM, DU, PWR, OHM, RTD, T/C

Assessment of conformity pursuant to Section 12, par. 4 b, d of Act No. 22/1997 Coll.

Conformity is assessed pursuant to the following standards:

el.safety	EN 61010-1
EMC:	EN 50131-1, chapt. 14 and chapt. 15 EN 50130-4, chapt. 7, EN 61000-4-11 EN 50130-4, chapt. 8, EN 61000-4-11 EN 50130-4, chapt. 9, EN 61000-4-2 EN 50130-4, chapt. 10, EN 61000-4-3 EN 50130-4, chapt. 11, EN 61000-4-6 EN 50130-4, chapt. 12, EN 61000-4-4 EN 50130-4, chapt. 13, EN 61000-4-5 EN 50130-5, chapt. 20 prEN 50131-2-1, article 9.3.1 EN 61000-4-8 EN 61000-4-9 EN 61000-3-2 ed. 2:2001 EN 61000-3-3: 1997, Cor.1:1998, Z1:2002 EN 55022, chapt. 5 and chapt. 6

and Ordinance
el. safety č. 168/1997 Coll.
EMC: č. 169/1997 Coll.

As evidence serve the protocols of authorised and accredited organisations:

VTÚE Praha, examination laboratory No. 1158, accredited by ČIA
VTÚPV Vyškov, examination laboratory No. 1103, accredited by ČIA

In Prague, December 18, 2003

Miroslav Hackl v.r.
the Executive

6. CERTIFICATE OF GUARANTEE

Product: **OMX 38 DC AC W RTD DU OHM**

Type:

Manufact.No.:

Date of sale:

For this instrument applies a guarantee period of 24 months of the date of sale to the user.

Defects occurring during this period due to manufacturing error or due to material faults shall be eliminated free of charge.

For instrument quality, function and construction the guarantee shall apply provided the instrument was connected and used accurately in compliance with the instructions for use.

The guarantee does not apply to defects caused by:

- mechanical damage
- transportation
- intervention of unqualified person including the user
- irreversible event
- other unprofessional interference

The manufacturer performs guarantee and post-guarantee repairs unless provided for otherwise.

Stamp, signature



ORBIT MERRET, spol. s r.o.
Vodňanská 675/30
198 00 Praha 9

Tel.: +420 281 040 200
Fax: +420 281 040 299
e-mail: orbit@merret.cz
www.orbit.merret.cz

