

**Sensor
Potentiometers**

Series SP2800

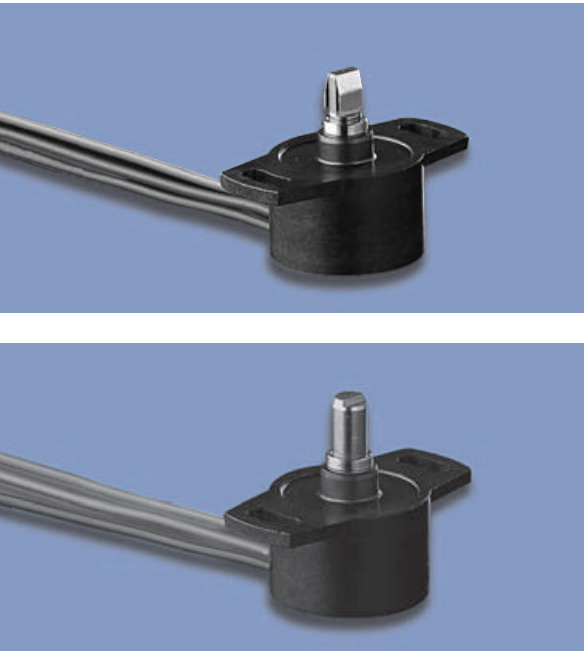

Designed to convert rotary movement into a proportional voltage, these position transducers utilize conductive plastic technology on both the resistance and collector tracks.

The housing and bearings are produced in a special high-grade temperature-resistant plastic material. Fixings are in the form of elongated slots which allow simplicity in mounting together with ease of mechanical adjustment.

The special backlash-free push-on coupling ensures extremely quick and simple installation. The transducer is not sensitive to either dirt or dampness. Electrical connections are made via conductors which are sealed into the housing. They are suitable for use with any of the termination methods currently in use. The use of elastomer-damped precious metal multi-finger wiper ensures reliable contact even under the severest of working conditions.

Special models with different electrical travels and shaft dimensions are available.

Special features

- available with push-on coupling or marked shaft
- Simple mounting
- Protection class IP 54 or IP 65
- long life
- good price/performance ratio

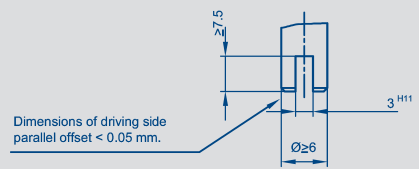
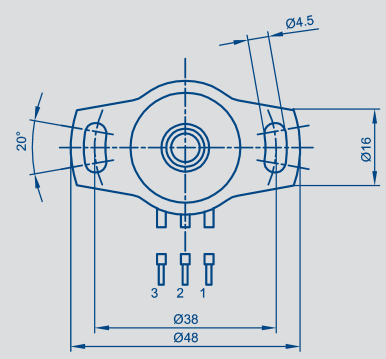
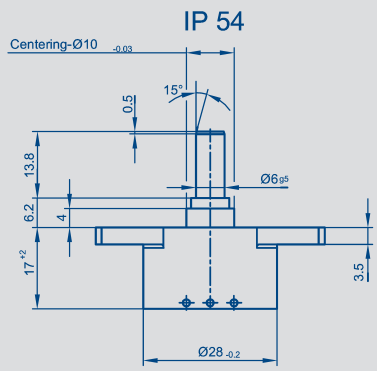

When the shaft marking is pointing to terminal 2 (red), the wiper is located in an electrical center position.

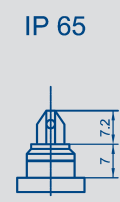
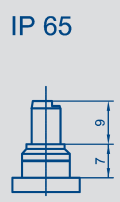
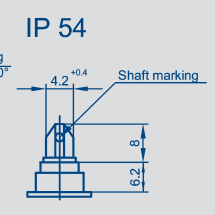
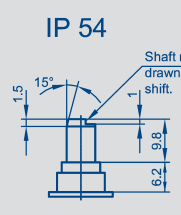

brown red orange
Schematic view on the shaft

Description	
Case	high-grade, temperature-resistant plastic
Shaft	stainless steel
Bearings	plastic friction bearings
Resistance element	conductive plastic
Wiper assembly	precious metal multi-finger wiper
Mounting position	any optional position
Electrical connections	three conductors, PTE-PEE-insulation

Mechanical Data		
Dimensions	see drawing	
Mounting	with 2 M4 fillister-head screws + washer	
Mechanical travel	360, continuous	°
Permitted shaft loading (axial and radial) static or dynamic force	20	N
Torque	0.5 (IP65) 0.2 (IP54)	Ncm
Maximum operational speed	120	min ⁻¹
Weight	32	g
Electrical Data		
Actual electrical travel	308 ± 2	°
Nominal resistance	5	kΩ
Resistance tolerance	±20	%
Repeatability	≤0.01 (Δ 0.03°)	%
Effective temperature coefficient of the output-to-applied voltage ratio	typical 5	ppm/K
Independent linearity	±0.3	%
Max. permissible applied voltage	42	V
Recommended operating wiper current	≤ 1	μA
Max. wiper current in case of malfunction	10	mA
Insulation resistance (500 VDC, 1 bar, 2 s)	≥ 10	MΩ
Dielectric strength (50 Hz, 2 s, 1 bar, 500 VAC)	≤ 100	μA
Conductor length, bared, tinned	approx. 300	mm
Conductor diameter	approx. 1	mm ²

Novotechnik Stiftung & Co.
Messwertaufnehmer OHG

Postfach 4220
73745 Ostfildern (Ruit)
Horbstraße 12
73760 Ostfildern (Ruit)

Tel. +49 (0) 711 / 44 89-0
Fax +49 (0) 711 / 44 89-150
info@novotechnik.de
www.novotechnik.de

© 12/2001
Art.-Nr.: 062 719
Printed in Germany

Environmental Data

Temperature range		
IP 54	-40...+100	°C
IP 65	-40...+150 (+150°C on request)	°C
Vibration	5...2000 A _{max} = 0.75 a _{max} = 20	Hz mm g
Life	>50 x 10 ⁶	movem.
Protection class	IP 54 or IP 65 (DIN 400 50 / IEC 529)	

Order designations

Type	Art.no.	
SP2801 A502	019220	6 mm shaft, IP 54
SP2821 A502	019240	Push-on coupling, IP 54
SP2831 A502	019221	6 mm shaft, IP 65
SP2841 A502	019241	Push-on coupling, IP 65
SP2801 S0002	019222	6 mm shaft, IP 54, ± 100°, R = 3 kΩ independent linearity ±1 %
SP2831 S0002	019227	6 mm shaft, IP 65, ± 100°, R = 3 kΩ independent linearity ±1 %
SP2841 S0002	019242	Push-on coupling, IP 65, ± 100°, R = 3 kΩ independent linearity ±1 %

Recommended accessories

Processor controlled indicators MAP... with display,
Signal conditioner MUP... /
MUK ... for standardized output signals

Important

All the values given in this data sheet for linearity, lifetime and temperature coefficient in the voltage dividing mode are quoted for the device operating with the wiper voltage driving on operational amplifier working as a voltage follower, where virtually no load is applied to the wiper ($I_e \leq 1 \mu\text{A}$).