

**NOVOSTRICTIVE
Transducer
Touchless**

TM1

Screw flange

Voltage

Mobile Applications

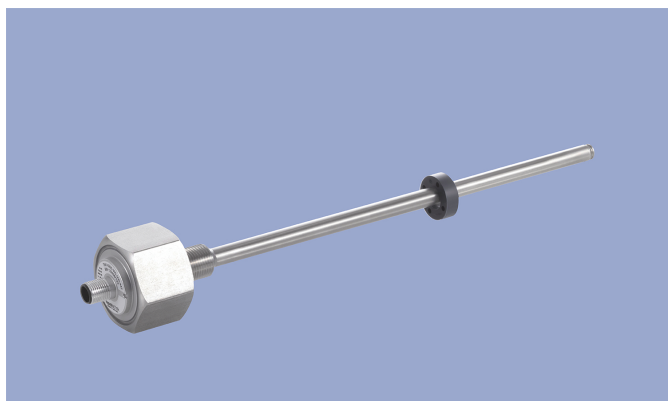
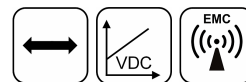

Special Features

- For integration in pneumatic and hydraulic cylinders
- Touchless magnetostrictive measurement technology
- Operating pressure up to 350 bar, peaks up to 450 bar
- Ring-shaped position marker does not contact sensor
- Unlimited mechanical life
- No velocity limit for position marker
- Absolute output
- Outstanding accuracy performance up to 0.04 %
- Wide range of supply voltage
- Optimized for use in mobile applications with highest EMC requirements such as ISO pulses and high interferences to ISO 11452, exceeds E1 requirements
- Other configurations see separate data sheets

Applications

Hydraulic or pneumatic cylinders in

- Agricultural and forestry machinery
- Construction machines
- Vehicles with loading and unloading devices
- Vehicles with extension arms

The absolute position transducer can be used directly in-cylinder and thus enables a compact and cost-effective position measurement. The sensor consists of a stainless steel flange welded to a pressure tight rod and can therefore be used in harsh environments.

The magnetostrictive measuring technology offers excellent accuracy for measuring lengths up to 2000 mm.

The passive ring-shaped position marker allows a mechanically decoupled measurement.

Description

Material	Flange: stainless steel 1.4307 / AISI 304L Flange cover: AlSiMgBi Rod: stainless steel 1.4571 / AISI 316Ti Sealing: O-ring NBR 90 SH A
Mounting	Screwed into cylinder via bushing M18x1.5 for screw plug hole per ISO 6149
Electrical connection	Connector M12x1, A-coded / Cable 3x 0.5 mm ² (AWG 20), PUR, unshielded

Mechanical Data

Dimensions	See dimension drawing
------------	-----------------------

Ordering Specifications

Ordering Specifications

Preferred types printed in bold

Supply voltage U_b

8: $U_b = 12/24$ VDC, 24 VDC

Output signal

1: 0.1 ... 10 VDC

4: 0.5 ... 4.5 VDC

5: 0.25 ... 4.75 VDC

Output characteristic

1: Rising output characteristic, seen from flange

2: Falling output characteristic, seen from flange

Electrical connection

104: Connector M12x1, 4-pin

251: Cable, 3-pole, unshielded, A = 1 m

253: Cable, 3-pole, unshielded, A = 3 m

255: Cable, 3-pole, unshielded, A = 5 m

T M 1 - **0 5 0 0** - **3 0 6** - **8 5 1** - **1 0 4**

Series

Mechanical version

306: Screw flange M18x1.5

308: Screw flange M18x1.5 with internal thread M4x6 at rod end, additional length 7.5 mm

Electrical measuring range

Standard lengths 0050 up to 2000 mm in 25 mm-steps

Other lengths on request

Drawing

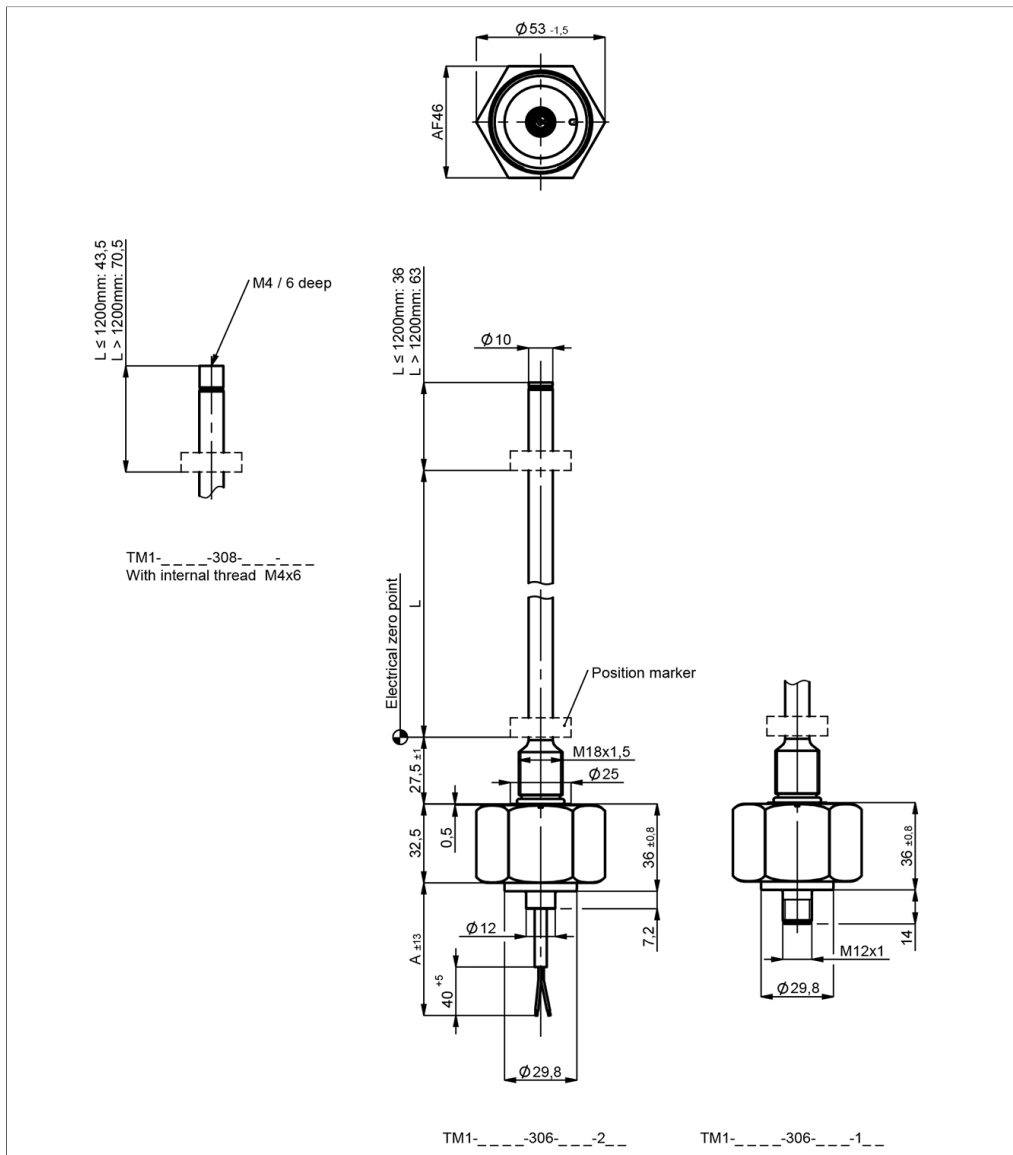

CAD data see
www.novotechnik.de/en/download/cad-data/

Technical Data

Type	TM1-____-306-84 - ____ TM1-____-306-85 - ____	TM1-____-306-81 - ____
Output signal	0.25 ... 4.75 V 0.5 ... 4.5 V	0.1 ... 10 V
Load	≥ 10 kΩ	
Sampling rate / Update rate	0.5 kHz	
Electrical measuring range (dim. L)	0 ... 50 mm up to 0 ... 2000 mm	
Absolute linearity	≤ ±0.04 %FS (min. 300 μm)	
Tolerance of electr. zero point	±1 mm	
Resolution	≤ 0.1 mm	
Repeatability	≤ ±0.1 mm	
Hysteresis	≤ ±0.1 mm	
Temperature error	typ. 50 ppm/K (min. 0.01 mm/K)	
Supply voltage Ub	12/24 VDC (8 ... 32 VDC)	24 VDC (16 ... 34 VDC)
Supply voltage ripple	≤ 10% Ub	
Power drain w/o load	< 1 W	
Overvoltage protection	36 VDC (permanent)	
Polarity protection	yes (-36 VDC)	
Short circuit protection	yes (output vs GND and supply voltage up to 36 VDC)	
Insulation resistance (500 VDC)	≥ 10 MΩ	
Environmental Data		
Max. operational speed	Mechanically unlimited	
Vibration IEC 60068-2-6	20 g, 10 ... 2000 Hz, Amax = 0.75 mm	
Shock IEC 60068-2-27	100 g, 11 ms (single hit)	
Protection class DIN EN 60529	IP67	
Operating temperature	-40 ... +105°C	
Operating humidity	0 ... 95 % R.H. (no condensation)	
Working pressure	≤ 350 bar	
Pressure peaks	≤ 450 bar	
Burst pressure	> 700 bar	
Life	Mechanically unlimited	
Functional safety	If you need assistance in using our products in safety-related systems, please contact us	
MTTF (IEC 60050)	346 years	346 years
EMC Compatibility		
ISO 10605 ESD (Handling/Component)	8 kV / 15 kV	
ISO 11452-2 Radiated HF-fields	100 V/m	
ISO 11452-4 BCI (Bulk current injection)	200 mA	
CISPR 25 Radiated emission	Level 4	
ISO 7637-2 Transient Emissions	Level 1/2	
ISO 7637-2 Pulses on supply lines	(1, 2a, 2b, 3a, 3b) Level 4	
ISO 7637-3 Pulses on output lines	(3a, 3b) Fast Level 2	
ISO 16750 Pulses on supply lines	Starting profile Level 4 @12 V / Level 3 @24 V, Load dump A +200 V	
EN 13309 Construction machinery		
ISO 14982 Agricult./forestry machines		
Emission/Immunity	Exceeds E1 requirements	
	The EMC measurements are conducted in a reference cylinder. The EMC properties can deviate when using different cylinders.	

Connection Assignment

Signal	Connector code 1__	Cable code 2__
Supply voltage Ub	Pin 1	BN
GND	Pin 3	WH
Signal output	Pin 2	GN
Do not connect	Pin 4	-

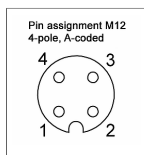

Technical Data Output Characteristics

Output characteristic

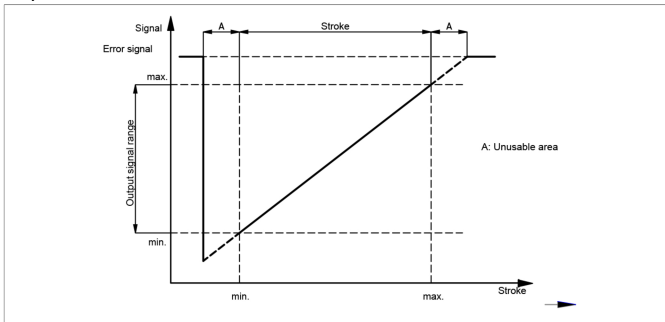

Output characteristic

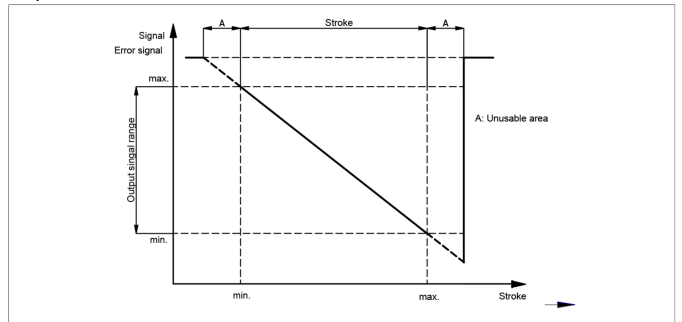

Position Markers

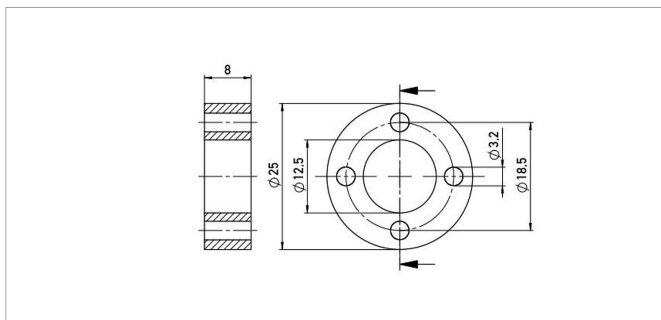
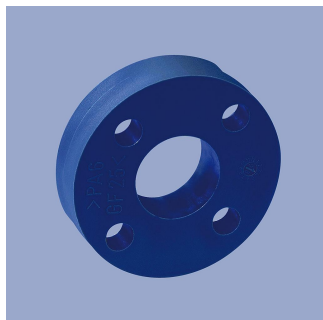

Z-TH1-P18

Ring position marker for fixation with screws M3
 Material PA6-GF
 Weight approx. 12 g
 Operating temp. -40 ... +100°C
 Surface pressure max. 40 N/mm²
 Fastening torque max. 100 Ncm
 of mounting

P/N	Pack. unit [pcs]
400005697	1

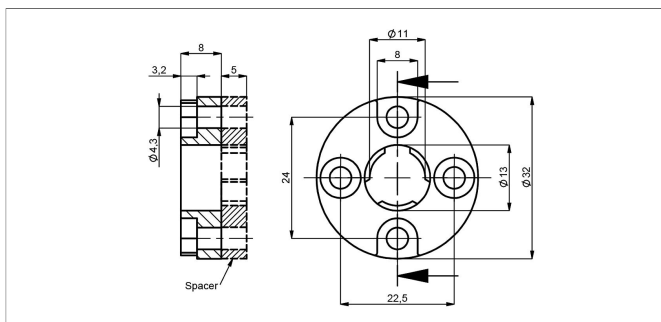
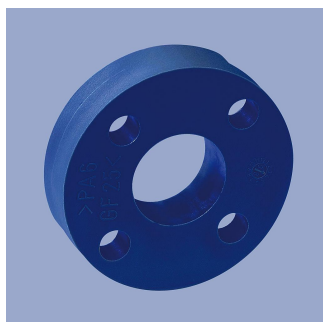

Z-TH1-P19

Z-TH1-PD19 With spacer

Ring position marker for fixation with screws M4, optionally with or without spacer
 Material PA6-GF, Spacer: POM-GF
 Weight approx. 14 g
 Operating temp. -40 ... +100°C
 Surface pressure max. 40 N/mm²
 Fastening torque max. 100 Ncm

P/N	Spacer	Pack. unit [pcs]
400005698	-	1
400107117	incl.	1

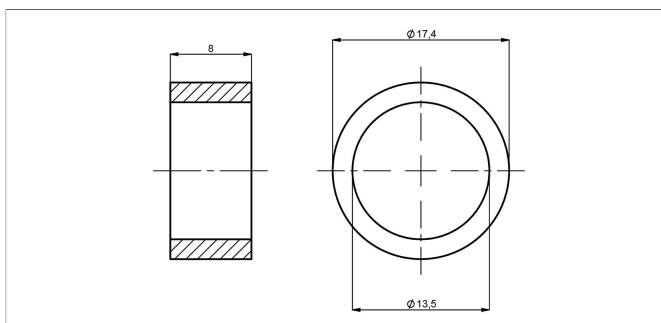
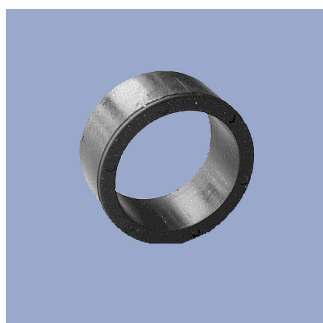

Z-TH1-P30

Ring position marker for mounting via lock washer and retaining ring

Material NdFeB bonded (EP)
 Weight approx. 5 g
 Operating temp. -40 ... +100°C
 Surface pressure max. 10 N/mm²

P/N	Pack. unit [pcs]
400106139	1

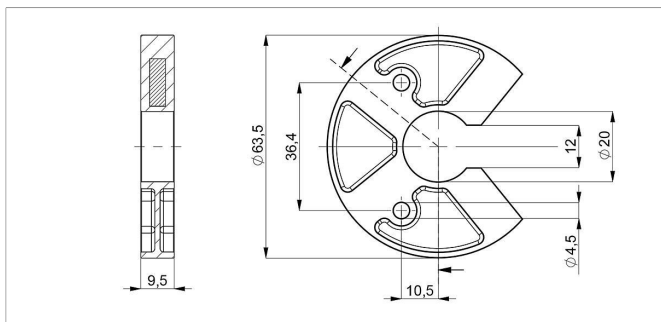

Z-TH1-P25

U-shaped position marker for fixation with M4 screws

Caution: for dimension of electrical zero point please follow the user manual!

Material PA6-GF
 Operating temp. -40 ... +105°C
 Surface pressure max. 40 N/mm²
 Fastening torque max. 100 Ncm
 of mounting

P/N	Pack. unit [pcs]
400105076	1

Position Markers

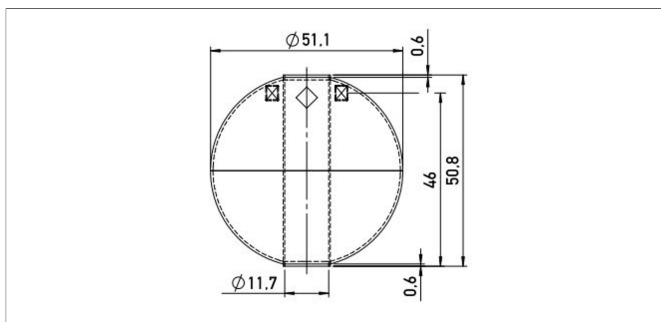

Z-TH1-P22

Ball-type floating position marker
Material Stainless steel 1.4571
Weight approx. 42 g
Operating temp. -40 ... +100°C
Compression strength ≤ 60 bar
Density 720 kg/m³
Immersion depth in water 36.7 mm

P/N	Pack. unit [pcs]
400056045	1

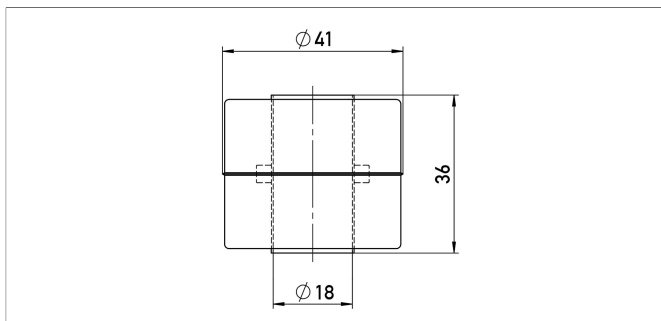
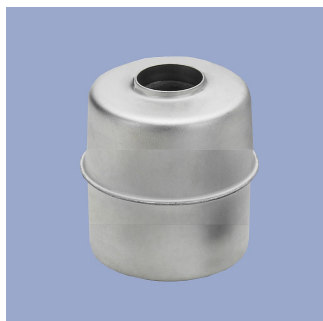

Z-TH1-P21

Cylinder floating position marker
Material Stainless steel 1.4404
Weight approx. 20 g
Operating temp. -40 ... +100°C
Compression strength ≤ 8 bar
Density 740 kg/m³
Immersion depth in water approx. 26.6 mm

P/N	Pack. unit [pcs]
400056044	1

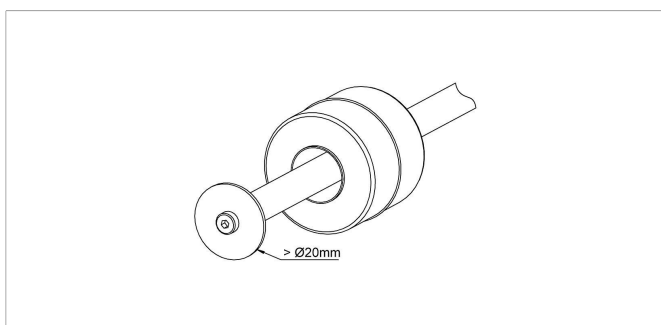

When using floating position markers, we recommend to secure the marker against loss with a washer at the rod end.

For this purpose, a sensor version with inner thread at the rod end is required (s. ordering code).

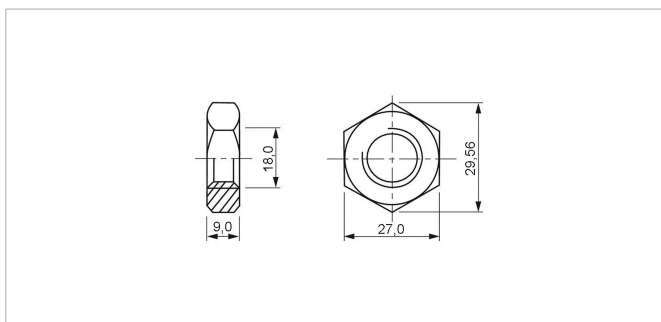

Z-TH1-M01

Lock nut ISO 8675, M18x1.5-A2

P/N	Pack. unit [pcs]
400056090	1

Connector System M12

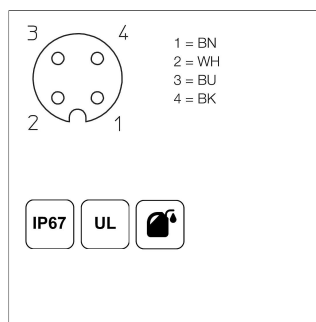
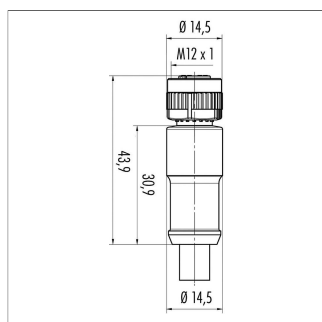

EEM-33-35/36/37
M12x1 Mating female connector, 4-pin, straight, A-coded, with molded cable, not shielded, IP67, open ended
Plug housing PA
Cable sheath PUR, \varnothing = max. 6 mm, -40 ... +85°C (fixed)
Lead wires PP, 0.34 mm²

P/N	Type	Length
400056135	EEM-33-35	2 m
400056136	EEM-33-36	5 m
400056137	EEM-33-37	10 m

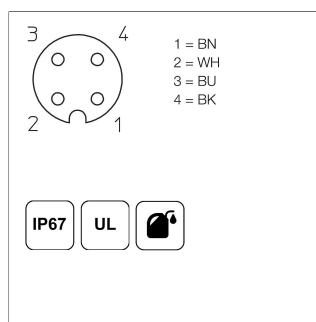
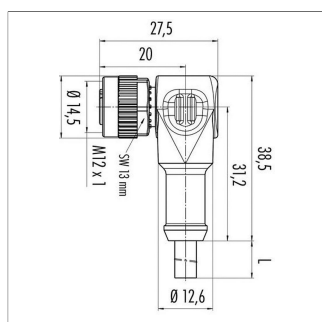

EEM-33-38/39/40
M12x1 Mating female connector, 4-pin, angled, A-coded, with molded cable, not shielded, IP67, open ended
Plug housing PA
Cable sheath PUR, \varnothing = max. 6 mm, -40 ... +85°C (fixed)
Lead wires PP, 0.34 mm²

P/N	Type	Length
400056138	EEM-33-38	2 m
400056139	EEM-33-39	5 m
400056140	EEM-33-40	10 m

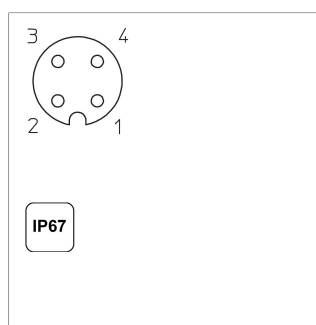
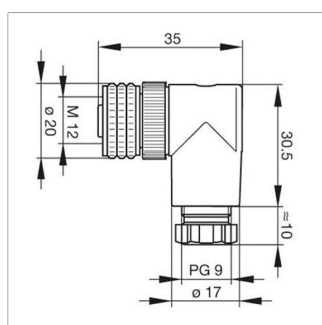

EEM-33-89
M12x1 Mating female connector, 4-pin, angled, A-coded, with coupling nut, screw termination, IP67, not shieldable
Operating temp. -25 ... +90°C
Plug housing PBT
For wire gauge 6 ... 8 mm, max. 0.75 mm²

P/N	Type
400005634	EEM-33-89

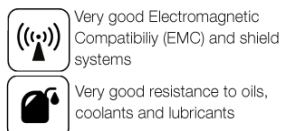
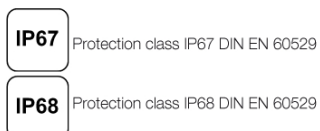

Novotechnik
Messwertaufnehmer OHG
P.O.Box 4220
73745 Ostfildern (Germany)
Horbstrasse 12
73760 Ostfildern (Germany)
Phone +49 711 4489-0
Fax +49 711 4489-118
info@novotechnik.de
www.novotechnik.de



© Aug 24, 2021

The specifications contained in our datasheets are intended solely for informational purposes. The documented specification values are based on ideal operational and environmental conditions and can vary significantly depending on the actual customer application. Using our products at or close to one or more of the specified performance ranges can lead to limitations regarding other performance parameters. It is therefore necessary that the end user verifies relevant performance parameters in the intended application. We reserve the right to change product specifications without notice.