

IN.01

3x UNIVERSAL INPUT - ISOLATED



UNIVERSAL INPUT

DC	±60 / ±150 / ±300 / ±1 200 mV
PM	0...5 mA / 0...20 mA / 4...20 mA / ±5 mA / ±20 mA 0...2 V / 0...5 V / 0...10 V / 0...40 V / ±2 V / ±5 V / ±10 V / ±40 V
OHM	0...100 Ω / 0...300 Ω / 0...1 kΩ / 0...3 kΩ / 0...10 kΩ / 0...30 kΩ
Pt	Pt 50 / Pt 100 / Pt 500 / Pt 1 000
Ni	Ni 1 000 / Ni 10 000
Cu	Cu 50 / Cu 100
T/C	J / K / T / E / B / S / R / N / L
DU	Linear potentiometer



CARD SETTINGS



The following parameters are edited in the setting

Select the **Position of the card** to be set. Use buttons ◀ ▶ to scroll among the fitted cards.

Type of the card fitted in the specified position.

Data transfer **priority** of the selected card. Bigger number of plugged-in cards slows down data flow on the bus. It can be optimized by setting priorities. The real value of the data flow can be then controlled in diagnostics. The maximum achievable data flow in slots A is 1100 frames/s, in slots B 550 frames /s.

Channel to be set. Use buttons ◀ ◀▶ ▶▶ ▶ to scroll among the channels. Number of possible selectable channels is determined by the card, which is being set

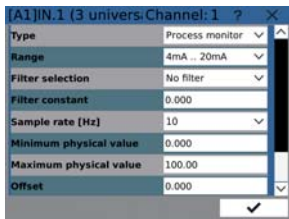

Button  is used to navigate to the settings of the selected channel.

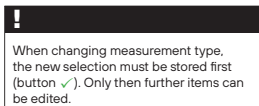

Type	DC V-A meter ▶ Process monitor ▶ Ohmmeter ▶ Thermometer Pt xxx ▶ Thermometer Cu xxx ▶ Thermometer Ni xxx ▶ Thermometer T / C ▶ Lin. potentiometer.
Range	DC ±60 mV ▶ ±150 mV ▶ ±300 mV ▶ ±1200 mV PM 0...5 mA ▶ 0...20 mA ▶ 4...20 mA ▶ ±5 mA ▶ ±20 mA ▶ 0...2 V ▶ 0...5 V ▶ 0...10 V ▶ 0...40 V ▶ ±2 V ▶ ±5 V ▶ ±10 V ▶ ±40 V OHM 100 Ω ▶ 300 Ω ▶ 1 kΩ ▶ 10 kΩ ▶ 10 kΩ ▶ 30 kΩ Pt Pt 50-3580 ▶ Pt 100-3580 ▶ Pt 500-3580 ▶ Pt 1000-3580 Cu Cu 50-4280 ▶ Cu 100-4280 Ni Ni 1000-6180 ▶ Ni 10000-6180 T / C J ▶ K ▶ T ▶ E ▶ B ▶ S ▶ R ▶ N ▶ L DU Lin. potentiometer
Filter selection	Floating floating arithmetic average of the number of measured values Exponential integration filter of the first order with a time constant measurement
Filter constant	Indicates the size of the filter
Rate	5...320 measurements / s
Min. physic. values	value that corresponds to the minimum selected range of the input values
Max. physic. values	value that corresponds to the maximum selected range of input values
Tare	to reset the values by non-zero input signals

* In temperature measurements (Pt, Ni, Cu, T / C) the conversion to a physical value (temperature) is carried out by the sensor regardless of the values.

INSTALLATION OF A NEW CARD

When installing a new card, always make sure the recorder is disconnected from the power supply!

1. Remove the recorder's back cover and break off the plugs covering the position where you intend to insert the new card. It is recommended to place analogue cards into faster slots in column „A“ (Speed of the bus: Slot „A“ 1 ms, Slot „B“ 2 ms).
2. Remove the card from its shipping container and from the ESD packaging and slide it carefully into the selected slot until you feel a gentle click
3. Replace the back cover and turn the device on
4. Setting of the card is described in the preceding paragraph

IN.01

TECHNICAL DATA

INPUTS

Number	3, isolated			
DC	Range	$\pm 60 \text{ mV} / \pm 150 \text{ mV} / \pm 150 \text{ mV}$	$> 10 \text{ M}\Omega$	3
		$\pm 1 \text{ 200 mV}$	$> 10 \text{ M}\Omega$	3
PM	Range	$0...5 \text{ mA} / 0...20 \text{ mA} / 4...20 \text{ mA}$	10Ω	1
		$\pm 5 \text{ mA} / \pm 20 \text{ mA}$	10Ω	1
		$0...2 \text{ V} / 0...5 \text{ V} / 0...10 \text{ V} / 0...40 \text{ V}$	$> 0,5 \text{ M}\Omega$	2
		$\pm 2 \text{ V} / \pm 5 \text{ V} / \pm 10 \text{ V} / \pm 40 \text{ V}$	$> 1 \text{ M}\Omega$	2
OHM	Range	$0...100 \Omega / 0...300 \Omega$		5
		$0...1 \text{ k}\Omega / 0...3 \text{ k}\Omega / 0...10 \text{ k}\Omega / 0...30 \text{ k}\Omega$		
	Connection*	2, 3 or 4 wire		
Pt	Type	Pt 100 / 500 / 1 000 Ω - 3 850 ppm	$-50^\circ...450^\circ\text{C}$	5
		Connection*	2, 3 or 4 wire	
Ni	Type	Ni 1 000 / Ni 10 000 - 6 180 ppm / $^\circ\text{C}$	$-200^\circ...250^\circ\text{C}$	5
		Connection*	2, 3 or 4 wire	
Cu	Type	Cu 50 / Cu 100 - 4 280 ppm / $^\circ\text{C}$	$-200^\circ...200^\circ\text{C}$	5
		Connection*	2, 3 or 4 wire	
TC	Type	J (Fe-CuNi)	$-200^\circ...900^\circ\text{C}$	3
		K (NiCr-Ni)	$-200^\circ...1\,300^\circ\text{C}$	
		T (Cu-CuNi)	$-200^\circ...400^\circ\text{C}$	
		E (NiCr-CuNi)	$-200^\circ...690^\circ\text{C}$	
		B (PtRh30-PtRh6)	$300^\circ...1\,820^\circ\text{C}$	
		S (PtRh10-Pt)	$-50^\circ...1\,760^\circ\text{C}$	
		R (Pt13Rh-Pt)	$-50^\circ...1\,740^\circ\text{C}$	
		N (Omegalloy)	$-200^\circ...1\,300^\circ\text{C}$	
L (Fe-CuNi)	$-200^\circ...900^\circ\text{C}$			
DU	Lin. potentiom. power supply	2,5 VDC / 6 mA		4
		min resistance of input is 500 Ω		

* When using inputs in 2-wire or 3-wire connection, it is essential to connect unused inputs on the terminal board using jumpers (2w • E+ / S+, E- / S-, 3w • E- / S-)

TECHNICAL SPECIFICATION

TC	50 ppm / $^\circ\text{C}$
Accuracy	$\pm 0,15\%$ of range (valid for 10 measur. / s)
Rate	5...320 measurements / s
Overload capacity	10x (t < 100 ms), 2x
Digital filters	Floating average, Exponential average
Compen. of conduct	max. 40 Ω / 100 Ω
Cold junction compensation (CJC)	automatic or manual
Watch-dog	reset after 500 ms
Calibration	at 25 $^\circ\text{C}$ and 40 % r.h.

POWER SUPPLY

Power supply	5 VDC, 24 VDC
Consumption	max. 150 mA

MECHANIC PROPERTIES

Dimensions	65 x 98 mm
Installation	to OMR 700

OPERATING CONDITIONS

Connection	connector terminal board, cross section < 1,5 mm ²
Working temperature	$-20^\circ...60^\circ\text{C}$
Storage temperature	$-20^\circ...85^\circ\text{C}$
IP rating	IP00
Construction	safety class I
El. safety	EN 61010-1, A2
Dielectric strength	2,5 kVAC over 1 min between bus and inputs 1 kVAC over 1 min between inputs
Insulation resistance*	for pollution degree II, measuring cat. III. Input / Bus - 300 V (PI), 150 (DI) Input / Input - 150 V (PI), 100 (DI)
EMC	EN 61326-1 (Industrial use)
Seismic resistance	IEC 980: 1993, par.6

* PI - Primary insulation, DI - Double insulation

IN.01

CONNECTION

IN.01

ORDER CODE

IN.01

Specifications

Used only for customised versions



00

IN.01

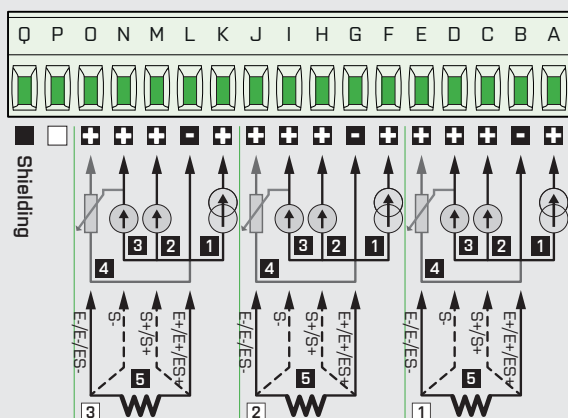

- 1** PM: 0...5/20 mA/4...20 mA
- 2** PM: $\pm 2 \text{ V} / \pm 5 \text{ V} / \pm 10 \text{ V} / \pm 40 \text{ V}$
- 3** DC: $\pm 60 / \pm 150 / \pm 300 / \pm 1\,200 \text{ mV}$
T/C: J/K/T/E/B/S/R/N/L
- 4** DU: Lin. potentiometer (> 500 Ω)
- 5** OHM: 0...0,1/0,3/1/3/10/30 k Ω
RTD: Pt 50/100/500/1 000
Cu: Cu 50/100
Ni: Ni 1 000/10 000



ORBIT MERRET, spol. s r. o.
Vodňanská 675 / 30
198 00 Praha 9
Czech republic

tel.: +420 281 040 200

fax.: +420 281 040 299

orbit@merret.eu

www.orbit.merret.eu

