

# IN.08

## 2x INPUT FOR STRAIN GAUGES, ISOLATED



### INPUT FOR STRAIN GAUGES

LC 0,5...2 / 1...4 / 2...8 / 4...16 mV/V

#### Rate

< 1 000 measurements / s

#### Accuracy

0,05 % of range

#### Load cell bridge excitation

5 VDC, load  $\geq 40 \Omega$

10 VDC, load  $\geq 80 \Omega$



### CARD SETTINGS

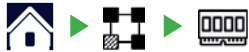

#### The following parameters are edited in the setting

Select the **Position of the card** to be set. Use buttons  $\leftarrow$   $\rightarrow$  to scroll among the fitted cards.

**Type of the card** fitted in the specified position.

Data transfer **priority** of the selected card. Bigger number of plugged-in cards slows down data flow on the bus. It can be optimized by setting priorities. The real value of the data flow can be then controlled in diagnostics. The maximum achievable data flow in slots A is 1100 frames/s, in slots B 550 frames / s.

**Channel** to be set. Use buttons  $\leftarrow$   $\ll$   $\gg$   $\rightarrow$  to scroll among the channels. Number of possible selectable channels is determined by the card, which is being set

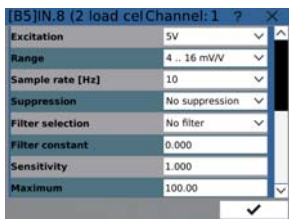

Button  is used to navigate to the settings of the selected channel.

Range	LC 0,5...2 $\rightarrow$ 1...4 $\rightarrow$ 2...8 $\rightarrow$ 4...16 mV/V
Filter selection	Floating floating arithmetic average of the number of measured values Exponential integration filter of the first order with a time constant measurement
Filtr constant	Indicates the size of the filter
Rate	5...1 000 measurements / s
Max. physic. values	value that corresponds to the maximum selected range of input values
Excitation	5 VDC or 10 VDC
Interference suppress.	20 Hz / off
Segment size	0,001...1 000
Functions	Weighing capacity Fixed tare Preset value Zero tracking Automatic reset

### INSTALLATION OF A NEW CARD

**When installing a new card, always make sure the recorder is disconnected from the power supply!**

1. Remove the recorder's back cover and break off the plugs covering the position where you intend to insert the new card. It is recommended to place analogue cards into faster slots in column „A“ (Speed of the bus: Slot „A“ 1 ms, Slot „B“ 2 ms).
2. Remove the card from its shipping container and from the ESD packaging and slide it carefully into the selected slot until you feel a gentle click
3. Replace the back cover and turn the device on
4. Setting of the card is described in the preceding paragraph

# IN.08

## TECHNICAL DATA

### INPUTS

Number	2, isolated	
LC	Range	1...4 mV/V 2...8 mV/V 4...16 mV/V
	Connection	6 wire
	Power supply	5 VDC or 10 VDC, load $\geq 80 \Omega$

### TECHNICAL SPECIFICATION

TC	50 ppm / °C
Accuracy	$\pm 0,05$ % of range (valid for 10 measur./s)
Rate	5...1 000 measurements / s
Overload capacity	10x (t < 100 ms), 2x
Digital filters	Floating average, Exponential average
Watch-dog	reset after 500 ms
Calibration	at 25°C and 40 % r.h.

### POWER SUPPLY

Power supply	5 VDC, 24 VDC
Consumption	max. 150 mA

### MECHANIC PROPERTIES

Dimensions	65 x 98 mm
Installation	to OMR 700

### OPERATING CONDITIONS

Connection	connector terminal board, cross section < 1,5 mm <sup>2</sup>
Working temperature	-20°...60°C
Storage temperature	-20°...85°C
IP rating	IP00
Construction	safety class I
El. safety	EN 61010-1, A2
Dielectric strength	2,5 kVAC over 1 min between bus and inputs 1 kVAC over 1 min between inputs
Insulation resistance*	for pollution degree II, measuring cat. III. Input / Bus - 300 V (PI), 150 (DI) Input / Input - 150 V (PI), 100 (DI)
EMC	EN 61326-1 (Industrial use)
Seismic resistance	IEC 980: 1993, čl.6

\* PI - Primary insulation, DI - Double insulation

## IN.08

### CONNECTION

## IN.08

### ORDER CODE

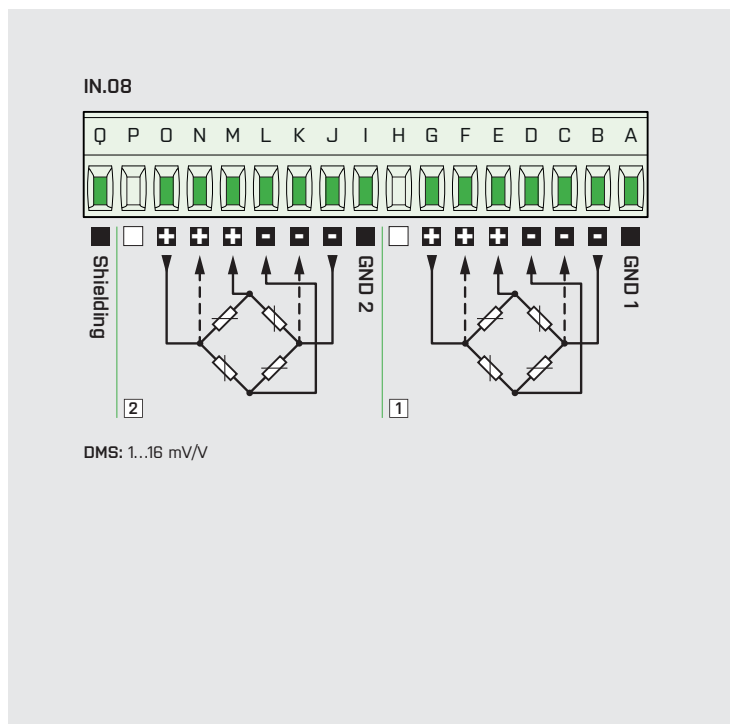

### IN.08

Specifications

Used only for customised versions



00

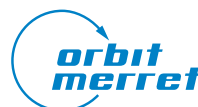

ORBIT MERRET, spol. s r. o.  
Vodňanská 675/30  
198 00 Praha 9  
Czech republic

tel.: +420 281 040 200  
fax.: +420 281 040 299  
orbit@merret.eu  
[www.orbit.merret.eu](http://www.orbit.merret.eu)

