

OMX 333UQC

Digital signal converter

UNIVERSAL COUNTER

- Input > Counter/Frequency/Time
- Range 0,1...50 000 Hz
- Scaling of measured values
- Input filter, Linearisation
- Output > Analogue/Data/Relays
- Setting from PC via OM Link
- Easy installation to DIN rail

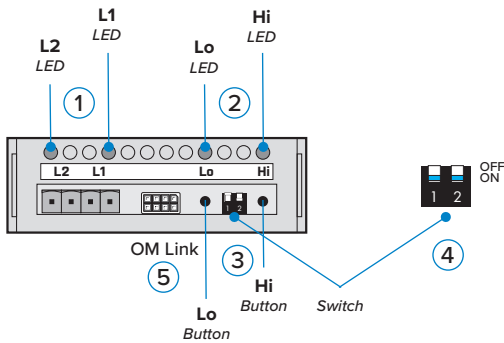

- ① * LED - Limits 1 and 2
- ② * LED - signalization of various states
- ③ Interaction buttons
- ④ Dip switch
- ⑤ OM Link to USB interface connector

Note: There is galvanic connection between OM Link connector and input!

⚠ DANGER ⚠	⚠ WARNING ⚠	⚠ CAUTION
<p>HAZARD OF ELECTRIC SHOCK, EXPLOSION OR ARC FLASH</p> <p>- Disconnect all power before servicing equipment and other supply lines</p> <p>Failure to follow this instruction will result in death or serious injury.</p>	<p>EQUIPMENT OPERATION HAZARD</p> <p>- Do not use this product in safety critical system. - Do not disassemble, repair or modify this product. - Do not operate beyond the recommended operating environment.</p> <p>Failure to follow these instructions can result in death, serious injury, or equipment damage.</p>	<p>EQUIPMENT OPERATION HAZARD</p> <p>- Install 100 mA fuse UL...Class CC ; IEC...gG</p> <p>Failure to follow this instruction can result in injury or equipment damage</p>

Electrical equipment should be installed, operated, serviced, and maintained only by qualified personnel. No responsibility is assumed by ORBIT MERRET for any consequences arising out of the use of this material.

2 Product Connection

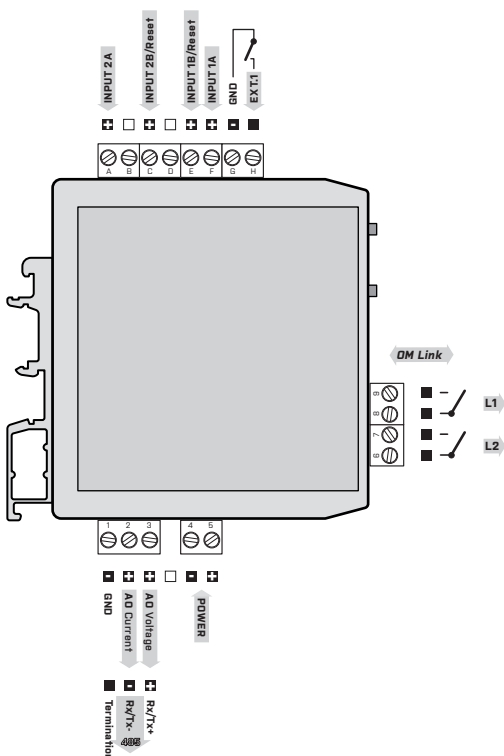

CONNECTIONS

TYPE	DESCRIPTION	CONNECTION
Input 1	input signal < 30 V	E/F + GND
Input 2	input signal < 300 V	A/C + GND

EXTERNAL INPUT

	DESCRIPTION	CONTROLS
EXT. 1	controlling input, its function is set in the menu (see. Menu > EXT.1)	upon contact, terminal (G + H)

①	Pitch	3,5 mm	5 mm
②	1,5 Nm 13.2 lb-in	Ø 2,5 mm / 0.1 in	Ø 3,5 mm / 0.14 in
③	mm in	mm in	mm in
	mm ² / AWG	0,05...1,5 / 30...14	0,05...2,5 / 30...12

Note: Contactors, high power electric motors, frequency drives and other power devices should not be in a close proximity of the meter. Input signal leads (measured value) should be separated from all power lines and power devices. Even though the meters has been designed and tested according to standards for industrial environment, we strongly advise to adhere to the above presented rules

Measuring type/mode selection















- Switching the switch No. 2 into the **ON** position  enters the programming mode - LED **Lo**  lights up and LED **Hi** , signals the type of measuring mode (table 1)
- Measuring mode selection: LED **Lo** is green  - By pressing the **Lo** button repeatedly you switch from one measuring mode to another and the LED **Hi**  indicates, by its flashing, the actually selected mode (table 1)
- Press button **Hi** to confirm the selected setting and go to the next menu item.

Table 1

LED Lo 		
LED Hi	Measuring mode	
	SINGLE - COUNTER	Counter
	SINGLE - FREQUENCY	Frequency
	QVADR - COUNTER	Couter for IRC sensors
	QVADR - FREQUENCY	Frequency for IRC sensors
	UP/DW - COUNTER	UP/DW Counter, měří na vstupech A, C (směr)
	UP/DW - FREQUENCY	UP/DW Frequency, měří na vstupech A, C (směr)
	UP + DW - COUNTER	UP - DW Conter, měří na vstupech A (UP), C (DW)
	UP + DW - FREQUENCY	UP - DW Frequency, měří na vstupech A (UP), C (DW)
	TIME	Timer















- Setting of type/level of inputs A and B - LED **Lo** is red  - By pressing the **Lo** button repeatedly you switch from one menu item to another. LED **Hi** , indicates the actually selected type/voltage level (table 2)
- Press button **Hi** to confirm setting you selected and go to the next menu item (if available for the given type), otherwise go back to type.

Table 2

LED Lo 	
LED Hi	Type/Komparační úroveň
	NPN - contact
	PNP - 4.5 V
	PNP - 10 V
	PNP - 15 V
	PNP - 20 V
	PNP - 25 V
	PNP - 30 V
	PNP - 35 V
	PNP - 40 V
	PNP - 45 V
	PNP - 50 V
	PNP - 55 V











- Setting only for „TIME“ mode (controlling stopwatch) - LED **Lo** is off . By pressing the **Lo** button repeatedly you switch from one menu item to another. LED **Hi** , by its flashing, indicates the actually selected option (table 3)

Table 3

LED Lo 		
LED Hi	Volba ovládání stopek	
	CONTIN.	Timer/clock keeps running while the instrument is on
	CONTAC.	Timer/clock keeps running while the external contact is on
	EDGE	Timer/clock is controlled by the edge of the measured signal - timer is activated by the edge (input signal exceeding comparative level) and deactivated by the next incoming edge
	RUN.ST.C.	Timer/clock is both controlled and zeroed by the edge of an activating signal - timer is activated by the edge (input signal exceeding comparative level) and both stopped and zeroed by the next incoming edge
	C.RUN.ST.	Timer/clock is both controlled and zeroed by the edge of the activating signal - timer is zeroed and launched by the edge of the input signal (input signal exceeding comparative level) and stops running when the second edge comes
	CLR.RUN.	Timer/clock is zeroed and launched by the edge of the activating signal
	CL.RU.RE.	Timer/clock is zeroed and launched by the edge of the activating signal. This cycle is repeated with every incoming edge
	START	Timer/clock is only launched by the edge of the activating signal















- Setting only for „TIME“ mode (stopwatch resetting) - LED **Lo** flash in cycles  By pressing the **Lo** button repeatedly you switch from one menu item to another. LED **Hi** , by its flashing, indicates the actually selected option (table 4)
- Setting of external input „EXT. 1“ - LED **Lo** is off  By pressing the **Lo** button repeatedly you switch from one menu item to another. LED **Hi** , by its flashing, indicates the actually selected option (table 4).
- Press button **Hi** to confirm the selected setting and switch the switch No. 2 into its **OFF** position 

Table 4

LED Lo 			
LED Hi	Funkce vstupů		
	Input „B“	Ext. 1	Function
	CLEAR	STOP + CLEAR	Stopky/hodiny se vynulují
	STOP + CLEAR	CLEAR	Stopky/hodiny se zastavují i vynulují
	STOP	STOP + CLEAR	Stopky/hodiny se zastaví

Setting of Limits 1 (2)

- After pressing button **Hi** (for Limit 2 it is button **Lo**) red LED **L.1** (**L.2**) starts flashing  and both LED **Lo** and **Hi** flash in cycles 
- Set dipswitch no.2 (for Limit L.2 it is switch no.1) to **ON**  LED **Lo** and **Hi** flash in cycles 
- On the OMX 333 input set the signal to the level required for the Limit to be actuated
- Select your setting by pressing the **Hi** button and switch the dipswitch no.2 to **OFF** 

Setting of Analogue/Data output















- By switching the dipswitch no.1 to ON  programming mode is accessed - LED Hi  lights up and LED Lo  signals the type of output by flashing (Table 5) or the rate of analogue output (Table 6)
- By repeated pressing of button Hi the types of analogue output are accessed (rate) and LED Lo  signals the the type of output (Table 5) or the rate of data output (Table 6)
- By pressing Lo the selected setting is confirmed and a next menu item can be accessed (only for further setting of data output)
- By repeated pressing of Lo button instrument's address can be set and LED Lo  signals by flashing the address of OMX 333 (Table 6), (this procedure only applies to setting of data output)
- Our setting is confirmed by pressing Lo button and programming mode is exited by switching dipswitch no. OFF 

Table 5

LED HI	ANALOGUE OUTPUT
LED LO	TYPE
	0..2 V
	0..5 V
	0..10 V
	±10 V
	4..20 mA (Er)
	4..20 mA
	0..20 mA
	0..5 mA

Changing analogue output (AO) range





















- The converter is preset at the factory (0 = 4 mA, 50000 = 20 mA)
- By switching dipswitches no.1 and no.2 to ON  programming mode is accessed - LED Lo and Hi flash alternatively 
- To input terminals of OMX 333 connect signal of requested level which equals to minimum range of AO and by pressing Lo button this value is recorded, LED Lo  flashes twice the normal rate
- To input terminals of OMX 333 connect signal of requested level which equals to maximum range of AO and by pressing Hi button this value is recorded, LED Hi  flashes twice the normal rate
- By switching dipswitches no.1 and no.2 to OFF  programming mode is exited

Table 6

LED HI	DATA OUTPUT	Rate	Address	Address PB
				
		300	0	0
		600	1	1
		1200	2	2
		2400	3	3
		4800	4	4
		9600	5	5
		19200	6	6
		38400	7	7
		57600	8	8
		115200	9	9
		230400	10	10
			11	11





Restoration of manufacturer's /user settings

- This is a good way how to return to the original manufacturer's setting especially when making a mistake during the set up process
- By pressing buttons Lo and Hi simultaneously for approx 2 s LEDs Lo and Hi 
- By switching dipswitches no. 1 and 2 to ON  the rate of flashing increases
- By pressing button Hi restoration of manufacturer's setting is executed (linearisation table, if it had been entered, is deleted), by pressing button Lo restoration of user settings including those which had been set via OM Link SW is executed, (linearisation table remains)
- By switching dipswitches no.1 and no.2 to OFF  this mode is exited

Note: For an easier unit configuration we recommend using our free PC SW called OM Link and the OM Link-USB II connector cable www.merret.cz/en/products/software/om-link

















Note: If there is a pause during configuration exceeding 60 seconds, the configuration mode closes down automatically and the device is switched into a measuring mode. In such case all unconfirmed selections will be lost.

Table 7

LED SYMBOL LEGEND	
	LED is off
	LED is on
	LED flashes
	LED flashes twice with a short pause
	LED cyclically blinks green and red

4

Error conditions

ERROR	LED LO	LED HI	CAUSE	ELIMINATION
E.d.U.			number is too small (large negative) to be displayed	change DP setting, channel constant
E.d.O.			number is too large to be displayed	change DP setting, channel constant
E.t.U.			number is below the linearization table value; Error table underflow	change input signal value or linearization table
E.t.O.			number is above the linearization table value; Error table overflow	change input signal value or linearization table
E.i.U.			Input quantity is smaller than permitted input quantity range	change input signal value or input (range) setting
E.i.O.			Input quantity is larger than permitted input quantity range	change input signal value or input (range) setting
E.H.U.			a part of the instrument does not work properly	send the instrument for repair
E.E.E.			data in EEPROM corrupted	perform restoration of manufacture setting, upon repeated error statement send instrument for repair
E.d.t.			data v EEPROM mimo rozsah	perform restoration of manufacture setting, upon repeated error statement send instrument for repair
E.C.L.			memory was empty (presetting carried out)	upon repeated error statement send instrument for repair, possible failure in calibration
E.in.			no input signal	check wiring
E.O.U.			no output signal	check wiring

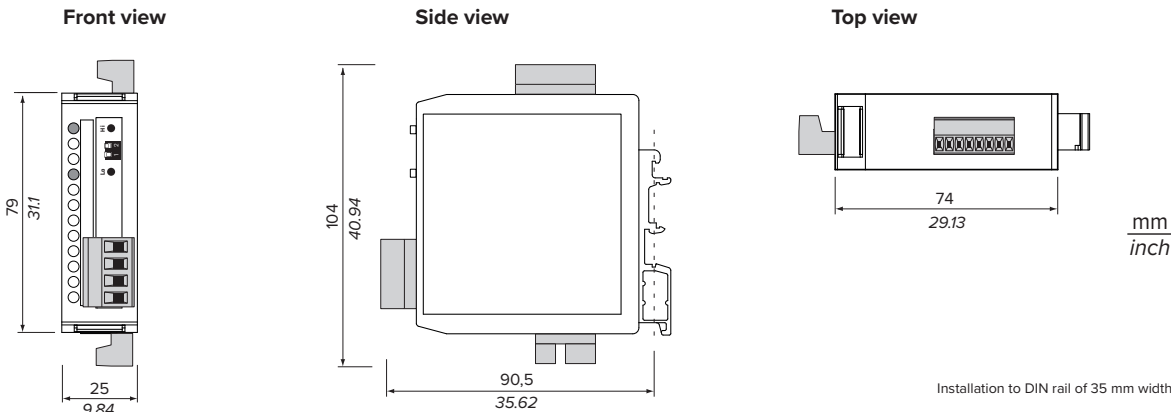
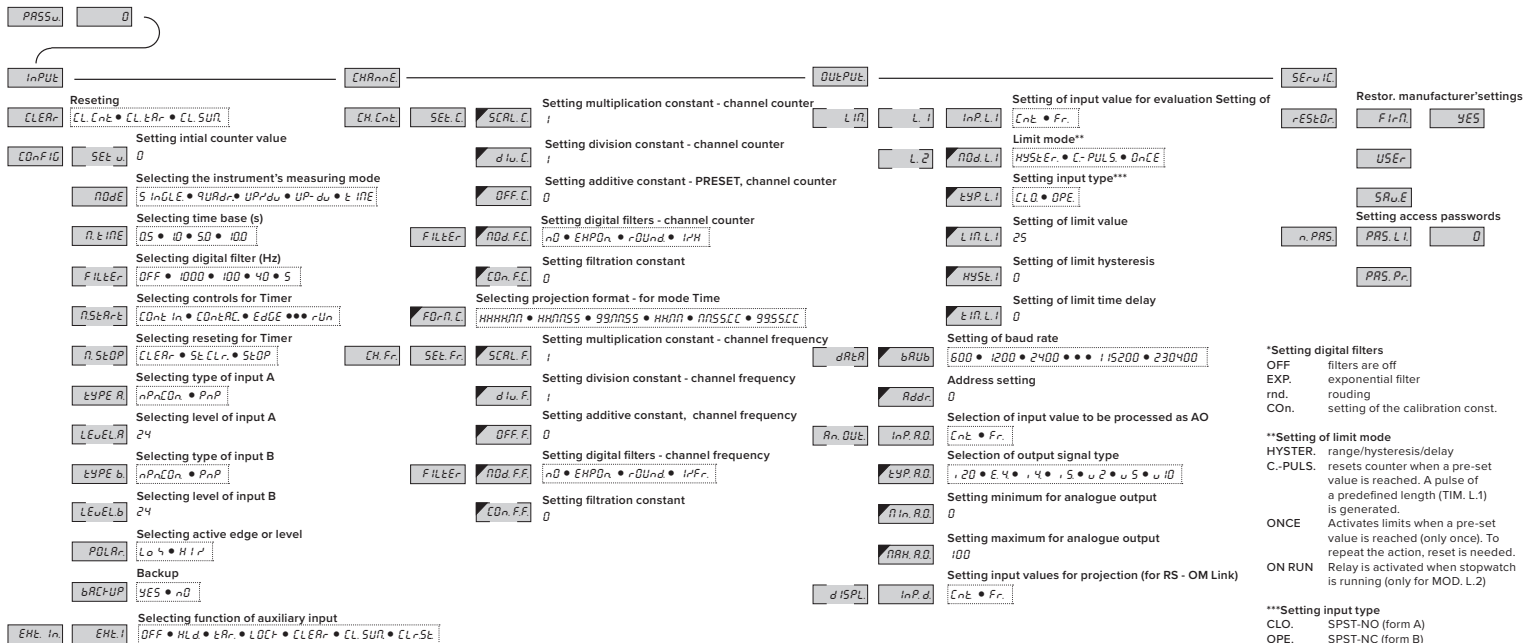

INPUT	
Number of inputs	2
Range	on contact, TTL, NPN/PNP 0...30 / 300 V, comparative levels are adjustable in the menu (9.7 / 14.4 / 19.2 / 23.9 / 28.7 / 33.5 / 38.3 V) or automatic
Measuring mode	Counter/Frequency UP or DOWN Counter/Frequency UP/DOWN Counter/Frequency for IRC sensor Timer/Clock 0.1...50 kHz (Mode SINGLE) 0.1...20 kHz (Mode UP/DW) 0.1...20 kHz (Mode QUADR. - Frequency) 0.1...20 kHz (Mode QUADR. - Counter)
INSTRUMENT ACCURACY	
TC	50 ppm/°C
Accuracy	±0.1% of the range
Time base	0.5/1/5/10 s
Multipl. constant	±0.00001...999999
Division constant	±0.00001...999999
Filtration constant	enables the user to select maximum valid frequency, which is processed (OFF/5/40/100/1000 Hz)
Digital filters	exponential filter, rounding, 1/frequency, measuring only completed revolutions (division constant)
External inputs	1, with the possibility of assigning various functions in the instrument's menu

Overload capacity	2x
Linearisation	linear interpolation in 50 points (only via OM Link)
OM Link	company communication interface for operation, setting and update of instruments
Watch-dog	reset after 500 ms
Calibration	at 25°C and 40% r.h.
COMPARATOR	
Type	digital, setting in v menu
Limits	±999999
Hysteresis	±999999
Delay	0...99.9 s
Mode	Hysteresis setpoint, band of hysteresis - Setpoint ±1/2 Hys.* and time defining the time-delay after which the relay will be activated C-Puls automatic reset of counter when a pre-set value is reached Once Setpoint, limit will be activated when the counter is reset On Run Relay is activated when stopwatch is running
Output	2x relays with switch-on contact (Form A), (250 VAC/30 VDC, 3 A)* 2x open collector, (30 VDC/100 mA)*
Reaction speed	< 50 ms
Relays	1/8 HP 277 VAC, 1/10 HP 125 V, Duty D300

* hodnoty platí pro odpovídavou zátěž

DATA OUTPUT	
Protocol	ASCII
Data format	8 bit + no parity + 1 stop bit
Rate	600...230 400 Baud
RS 485	isolated, addressing (max. 31 instruments)
ANALOG OUTPUT	
Typ	isolated, programmable with 16-bit D/A converter, type and range are selectable in menu
Non-linearity	0.1 % of range
TC	15 ppm/°C
Rate	response to change of value < 1 ms
Output	0...2.5/10 V, ±10 V, 0...5 mA, 0/4...20 mA (comp. < 500 Ω/12 V), Detection of broken loop (3.6 mA)
Ripple	5 mV residual ripple at output voltage of 10 V
POWER SUPPLY	
Power	12...30 VDC/24 VAC, ±10 %, 2 VA, PF≥0.4, I _{sp} ≤40 A/1 ms, non-isolated 10...30 VDC/24 VAC, ±10 %, 2 VA, PF≥0.4, I _{sp} ≤40 A/1 ms, isolated
MECHANIC PROPERTIES	
Material	PA66, incombustible UL 94 V-0, blue
Dimensions	90.5 x 79 x 25 mm
Installation	on DIN rail, width 35 mm

OPERATING CONDITIONS	
Connection	connector terminal blocks, section < 1.5/2.5 mm ²
Stabilization period	within 5 minutes after switch-on
Working temp.	-20...60°C
Storage temp.	-20...85°C
Protection	IP20
Construction	safety class I
El. safety	EN 61010-1, A2
Dielectric strength	2.5 kVAC after 1 min. between power and input 2.5 kVAC after 1 min. between input and output 4 kVAC after 1 min. between input and relays
Insulation resist.*	for pollution degree II, measurement cat. III power supply > 300 V (ZI), 255 V (DI) input/output > 300 V (ZI) input/output > 300 V (DI)
EMC	EN 61326-1 (Průmyslová oblast)

* ZI - Základní izolace, DI - Dvojí izolace



Measuring instruments of the OMX 333 series conform to the European regulation 2014/30/EU and 2014/35/EU

This product must be installed, connected and used in compliance with prevailing standards and/or installation regulations. As standards, specifications and designs develop from time to time, always ask for confirmation of the information given in this publication.



ORBIT MERRET, spol. s r.o.
Vodňanská 675/30
198 00 Prague 9
Czech Republic

☎ +420 - 281 040 200 ✉ orbit@merret.eu